

Radio-Electronics

HUGO GERNSBACK, Editor-in-chief

60c ■ JUNE 1967

TELEVISION · SERVICING · HIGH FIDELITY

A
GERNSBACK
PUBLICATION

Photo Buffs...
BUILD
Flash Slave \$5

SPECIAL ISSUE

Everyday Electronics

HOME

- Solid-State Appliances 42
- Future Electronic Household 34

PROFESSIONAL

- State of the Industry 37
- 5-in-1 TV Shop 55

HOBBY

- Shutterbug Electronics 58
- Sounds of Music 53

Housewife builds
stereo receiver



TRIPLETT

EXTRA QUALITY IS HIDDEN*

MODEL 630 V-O-M PRICE † \$580⁰⁰

Standard Of The Industry



USES UNLIMITED:

- Field Engineers
- Application Engineers
- Electrical, Radio, TV, and Appliance Servicemen
- Electrical Contractors
- Factory Maintenance Men
- Industrial Electronic Maintenance Technicians
- Home Owners, Hobbyists

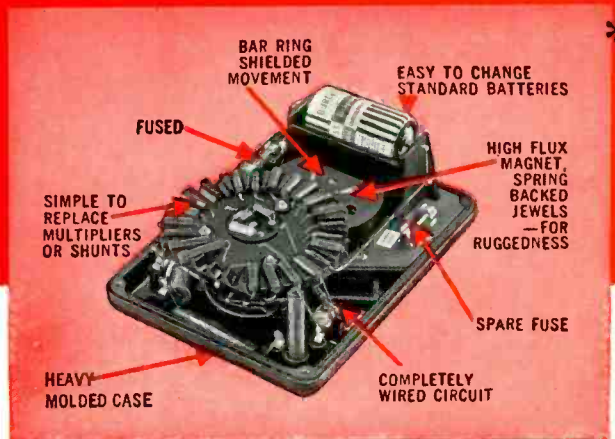

FACTS MAKE FEATURES:

- 1** Popular streamlined tester with long meter scales arranged for easy reading. Fuse protected.
- 2** Single control knob selects any of 32 ranges—less chance of incorrect settings and burnouts.
- 3** Four resistance ranges—from .1 ohm reads direct; 4½ ohm center scale; high 100 megohms.

Attention to detail makes the Triplet Model 630 V-O-M a lifetime investment. It has an outstanding ohm scale; four ranges—low readings .1 ohm, high 100 megs. Fuse affords extra protection to the resistors in the ohmmeter circuit, especially the X1 setting, should too high a voltage be applied. Accuracy 2% DC to 1200V. Heavy molded case.

†630A same as 630 plus 1½% accuracy and mirror scale only \$680⁰⁰

TRIPLETT ELECTRICAL INSTRUMENT COMPANY, BLUFFTON, OHIO

RANGES

DC VOLTS	0-3-12-60-300-1,200-6,000 at 20,000 ohms per volt.
AC VOLTS	0-3-12-60-300-1,200-6,000 at 5,000 ohms per volt.
OHMS	0-1,000-10,000.
MEG OHMS	0-1-100.
DC MICRO-AMPERES	0-60 at 250 millivolts.
DC MILLI-AMPERES	0-1-2-12-120 at 250 millivolts.
DC AMPERES	0-12.

DB: -20 to +77 (600 ohm line at 1 MW).

OUTPUT VOLTS: 0-3-12-60-300-1,200; jack with condenser in series with AC ranges.

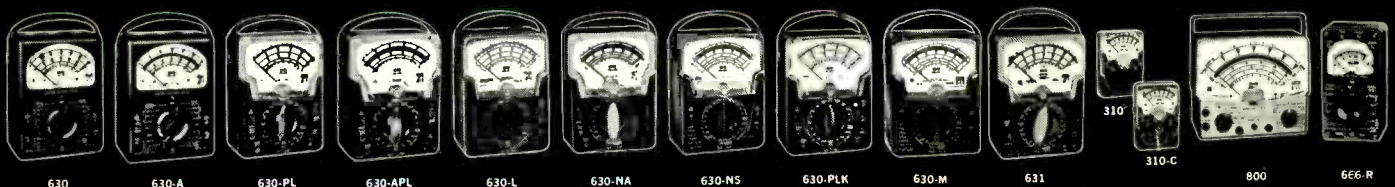

THE WORLD'S MOST COMPLETE LINE OF V-O-M'S. AVAILABLE FROM YOUR TRIPLETT DISTRIBUTOR'S STOCK.

NOW! a pocket portable that tunes police and standard broadcasts, for just 24⁹⁵

SOLD ONLY BY RADIO SHACK! 150 STORES IN 31 STATES!



tune in crisis and real life drama as it happens with the amazing Realistic Patrolman . . . the monitor radio that's your "hot line" to news in the making! Each model

features VHF plus the regular broadcast band for news and sports . . . continuous no-drift tuning . . . batteries and AC adaptor. Proven performance — 1000's already in use. Available only at *Radio Shack*, a nationwide store chain founded in 1923. Order in person, by phone, by mail. The reliable *Patrolman* is the "buy" of the year at \$24.95.

POLICE
Civil Defense
and Emergency
FIRE
Mobile Telephone
and Industrial
TAXIS
Railroads
and Trucks
PLANES

REALISTIC[®] PATROLMAN™

Size 6x3½". Net wt. 1 lb. Ship wt. 3 lbs.
Built-in AM and VHF antennas.

HIGH BAND
VHF: 147-174 MC
AM: 535-1605 KC

24⁹⁵

Order #12-627

LOW BAND
VHF: 30-50 MC
AM: 535-1605 KC

24⁹⁵

Order #12-628

JETSTREAM AIR BAND

VHF: 108-135 MC
AM: 535-1605 KC

21⁹⁵

Order #12-626

117V AC ADAPTOR

Eliminates (and recharges) batteries for these radios.

4⁹⁵

Order #12-702



**FREE 1967
RADIO SHACK CATALOG**

Check coupon below.



ORDER NOW FROM THE RADIO SHACK® STORE NEAREST YOU!

ARIZONA — Phoenix
ARKANSAS — Little Rock
CALIFORNIA — Anaheim, Bakersfield, Covina, Downey, Garden Grove, Glendale, Inglewood, La Habra, Long Beach, Los Angeles, Mission Hills, Mountain View, Oakland, Pasadena, Pomona, Reseda, Sacramento, San Bruno, San Diego, San Francisco, Santa Ana, Santa Monica, Torrance, West Covina
COLORADO — Denver
CONNECTICUT — Hamden, Manchester, New Britain, New Haven, New London, Orange, Stamford, West Hartford
FLORIDA — Jacksonville, Orlando
GEORGIA — Atlanta
ILLINOIS — Chicago

KANSAS — Wichita
LOUISIANA — New Orleans
MAINE — Portland
MARYLAND — Langley Park
MASSACHUSETTS — Boston, Braintree, Brockton, Brookline, Cambridge, Dedham, Framingham, Lowell, Medford, Natick, Quincy, Saugus, Springfield, Waltham, West Springfield, Worcester
MICHIGAN — Detroit
MINNESOTA — Minneapolis, St. Paul
MISSOURI — Kansas City, St. Joseph, St. Louis
NEBRASKA — Omaha
NEW HAMPSHIRE — Manchester
NEW JERSEY — Pennsauken
NEW MEXICO — Albuquerque
NEW YORK — Albany,

Binghamton, Buffalo, New York, Schenectady, Syracuse
OHIO — Cincinnati, Cleveland
OKLAHOMA — Oklahoma City, Tulsa
OREGON — Portland
PENNSYLVANIA — Philadelphia, Pittsburgh
RHODE ISLAND — Providence, East Providence
TENNESSEE — Memphis, Nashville
TEXAS — Abilene, Arlington, Austin, Brownsville, Corpus Christi, Dallas, El Paso, Fort Worth, Houston, Lubbock, Midland, San Antonio, Sherman, Waco
UTAH — Salt Lake City
VIRGINIA — Arlington, Virginia Beach
WASHINGTON — Seattle

RADIO SHACK { East: 730 Commonwealth Ave., Boston, Mass. 02215
West: 1515 So. University Dr., Ft. Worth, Tex. 76107

- "Patrolman" High Band/AM Radio \$24.95*
- "Patrolman" Low Band/AM Radio \$24.95*
- "Jetstream" Air Band/AM Radio \$21.95*
- Plug-in AC Adapter for Radios \$ 4.95*
- FREE 1967 Radio Shack catalog Dept. RU

*Add 50c per item for postage and handling.

NAME _____
STREET _____
CITY _____ STATE _____ ZIP _____

Circle 8 on reader's service card

← Circle 7 on reader's service card

Our Electronic Future

THE 1970's are less than 3 years away. What will you be doing 3 or 5 or 10 years from now?

Homes in the 1970's will approach a "total-electronic" idea—every possible use of electronics, some of them unknown today. In the R&D lab, you can be creating electronic contrivances framed in concepts now only hinted at. In your home and office, you can be living, playing, and working in unimaginable electronic comfort. In your service shop, the electronics you see and work with today will have evolved into fascinating new household and entertainment devices.

Do you see yourself in one of those pictures? If you like electronics as much as most of our readers do, you will be making the most of these sweeping changes—and, in fact, helping move them along.

You electronic engineers and lab technicians will catch the brunt of a demand to advance home-electronic technology in high gear. The heat will be on you to create some entirely new form of home entertainment. Room-size 3-D color television and 3-D sound will be nice, but old hat; consumers take things for granted very quickly and then demand new ideas, new products, new entertainment, new worksavers.

The broader your training and awareness of new developments, the more likely you'll be in the *avant garde* whose success stems from innovative talent. If you're an advanced experimenter at home, your chance is exceptional to come up with ideas that will move the total-electronic concept ahead in broad leaps.

Even if your electronic interest is passive, you can't escape the effects of the all-electronic way of living. Your wife will cook and shop by computer and call you to dinner by private video communicator. Your office will, unattended, forward data and messages to your work center at home for you to evaluate and process. You'll find the facts you need in your home-computer file, or you can get them from a central information-retrieval system you can dial on your visual dataphone. You can help the children with their homework the same way. At night, you'll be able to study by electronic mind-stimulation while you slumber in a sleep-inducing atmosphere, computer-controlled for your very own preferences of humidity, temperature, circulation and scent.

If you're a service technician, you have the brightest opportunity of all. The technician of 1970 can be a

different sort of guy from that of today, because his electronic surroundings will be changed. For the technician who is prepared, the future is assured. The shop owner who says "I don't have time to read about fuel cells and 3-D and laser communications and heatless cooking and all that stuff" is hiding his head in the sands of his present work; come the 1970's, he won't have a competitive chance.

Look again at the house with electronics controlling almost every function. Who will keep such a house working? Homeowner-handyman? Not a chance. Plumber? Electrician? TV repairman? Their training won't be up to it.

The total-electronic home will need a total-electronic-home technician. He can be called simply a total-home technician, because to say "total-home" will *mean* electronic. He will be an electronic generalist—a shirt-and-tie man who is paid for his knowledge and training. He can do well financially with 100 total-electronic homes on maintenance contract with a yearly fee.

He will have to know his business well. The half-trained skimp-along technician will eventually pack his tools and find a field that's less demanding. The total-home owner will be extremely dependent on some technician's skill; he won't bother with an incompetent or a technician with marginal training.

Most significant, however, is this: Much of the technology in the home of the future is here, now, today. All-electronic homes can be put together with present knowledge and hardware.

So why wait? About 70% of service technicians we've surveyed tell us they intend to stay in the business. If you're one of these, the best opportunity of your life is opening in front of you. If you get ready for it, if you think in terms of total electronics, if you make sure you are trained to troubleshoot *everything* in a customer's home—you can begin practicing as a total-home technician right now. Then, as technology progresses, you'll already be oriented to the total-home concept of our electronic future.

Forest H. Belt

Radio-Electronics

June 1967 VOL. XXXVIII No. 6
Over 55 Years of Electronics Publishing

EDITORIAL

- 2 Our Electronic Future**.....Forest H. Belt

SPECIAL ON CONSUMER ELECTRONICS

- 34 House of Tomorrow**.....Bruce Ward
Total electronics is the name of the game
- 37 Midyear Report on Electronics**.....Larry Allen
State of the industry at the 6-month checkpoint
- 57 First Consumer Electronics Show**
Showcase for home entertainment
- 60 Radio-Electronics Interviews Consumers Union**....Forest H. Belt
A report on performance testing of electronic equipment

CONSUMER ELECTRONICS/ AUDIO—HIGH FIDELITY

- 32 Housewife Builds FM Stereo**.....Jeff Tracy and Lee Spencer
Kit-assembly project by a nontechnical woman
- 49 Baffle: Speaker—Air Interface**.....James F. Novak
Mysteries of the speaker enclosure explained
- 52 Special Sounds of Organ Music**.....Richard H. Dorf
The unusual circuits that form them
- 66 Equipment Report: Heathkit-Magnecord Model AD-16**
Professional Tape Recorder

CONSUMER ELECTRONICS/ PROJECTS TO BUILD

- 45 An Electronic Slave Flash for \$5**.....Emerald E. Keith
Build this useful photo accessory
- 77 Build an IC Sound Relay**.....Lyman E. Greenlee
Speak and it shall be done

CONSUMER ELECTRONICS/ AROUND THE HOUSE

- 42 Solid State in Electric Appliances**.....Thomas R. Haskett
Many of them are electronic today
- 46 Burglars Got It Bad—And That's Good**.....Jack Darr
A review of modern theft and motion-alarm circuits
- 58 The Solid-State Camera is Here!**.....Ray Clifton
Now—transistors for the shutterbug

GENERAL ELECTRONICS

- 16 In the Shop . . . With Jack**.....Jack Darr
Service Clinic
- 41 The Technician's Apprentice**.....Phyllis Barlow
- 55 Five-in-One TV Shop**.....Warren Smith
America's most unusual service business
- 82 R-E Puzzler**
- 91 R-E Puzzler Answer**.....Edmund A. Braun

THE DEPARTMENTS

- | | |
|--|---------------------------------|
| 14 Correspondence | 12 New Briefs |
| 91 New Books | 90 Noteworthy Circuits |
| 76 New Literature | 84 Technotes |
| 73 New Products | 91 Try This One |
| 86 New Semiconductors,
Microcircuits & Tubes | 91 50 Years Ago |
| | 70 Reader's Service Page |



p 34—ELECTRONIC HOME

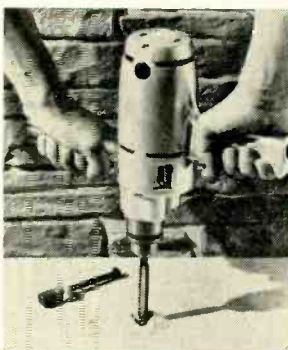

p 42—TOOL CONTROLS



p 46—SAFE WATCHDOGS



p 52—ELECTRONIC TONES



p 60—R-E RATES CU

RADIO - ELECTRONICS, JUNE 1967, Volume XXXVIII, No. 6. Published monthly by Gernsback Publications, Inc., at Ferry St., Concord, N. H. 03302. Editorial, Advertising, and Executive offices: 154 West 14th Street, New York 10011. Circulation Office, Boulder, Colo. 80302.

Second-class postage paid at Concord, N. H. Printed in U.S.A. One-year subscription rate: U. S. and possessions, Canada, \$5. Pan-American countries, \$6. Other countries, \$6.50. Single copies: 60c. © 1967, by Gernsback Publications, Inc. All rights reserved. POSTMASTERS: Notices of undelivered copies (Form 3579) to Boulder, Colo. 80302.

COVER FEATURE



p 32—Take a busy mother of two, with no previous electronics knowledge or experience. Give her an FM-stereo receiver kit. Can she build it? Will it work?

SIMPLE CAMERA FLASH



p 45—You can build this slave attachment to fill in light in your flash pictures. It's self-contained, with no external wires, and triggers automatically.



Member,
Institute of High Fidelity.
Radio-Electronics is indexed in
Applied Science & Technology
Index (formerly Industrial
Arts Index)

NEWS BRIEFS

SUBJECTIVE COLOR TV?

Two independent researchers have challenged classic color-perception theories. George Biernson (of Sylvania Electric's Applied Research Laboratory in Waltham, Mass.) presented a paper to the annual IEEE Convention in New York City in March. He disputed the theory of red, green and blue cones in the retina. Instead, he said, perhaps the eye detects color with the aid of rhythmic optical modes or patterns in the cones. He claimed, further, that there is little similarity between the human eye and a color-TV camera.

Meanwhile, a patent was issued to James F. Butterfield (who assigned it to the Battelle Development Corp. of Richland, Wash.) covering a new color TV system. The process, now being offered for commercial use (by Color-Tel Corp. of Los Angeles) produces "subjective" color from black-and-white receivers. There is no modification of the CRT's—a special pulsing light code is used at the TV station when the original camera signal is processed.

Do you suppose the tricolor kinescope will become a (black and) white elephant?

COMMERCIAL RADIO OVERSEAS

In January the Government of India announced that it had decided to allow commercial advertising on All India Radio. The system will permit both spot announcements and completely sponsored programs. Television advertising was approved in principle, but no specific plan was announced at that time.

This column carried an item in the January 1967 issue to the effect that commercial radio was about to start in Great Britain. That announcement was in error. A *proposal* to that effect had been made in England, but it was not approved by the authorities. The new popular radio service will be financed the same as radio has always been in the United Kingdom—by a license fee on receivers.

THE VANISHING TECHNICIAN

The Electronic Industries Association is planning a program to attract and train more electronic service

technicians. They claim industry lacks from 50,000 to 75,000 technically trained people; the gap could increase to 400,000 in 10 years if preventive measures aren't taken now.

At a recent conference of EIA's Consumer Products Division, the Executive Committee appropriated up to \$25,000 to explore the problem and determine various solutions to it. Possibility: A technician-training program, supported by government agencies, by manufacturers, or by foundations.

FIBER OPTICS AT IEEE

This year's annual convention of the Institute of Electrical and Electronics Engineers in New York City had several surprises. One was an os-

cillograph that measures and records high-frequency analog data at up to 1 MHz, and writes at speeds of more than a million inches per second.

Heart of the new instrument is a new Sylvania CRT (see first photo) with a 3 x 5-inch fiber-optic faceplate. The SC4082F employs a specially designed electron gun to produce a high-resolution, electrostatically deflected beam. The image is produced by a special phosphor which emits ultraviolet light. This image is then transferred directly to the outside surface of the fiber-optic faceplate. The faceplate is composed of tiny glass fibers, two million per square inch.

The complete oscillograph (shown in the second photo) is made by Honeywell and called the model 1806 Visicorder. Patterns displayed on

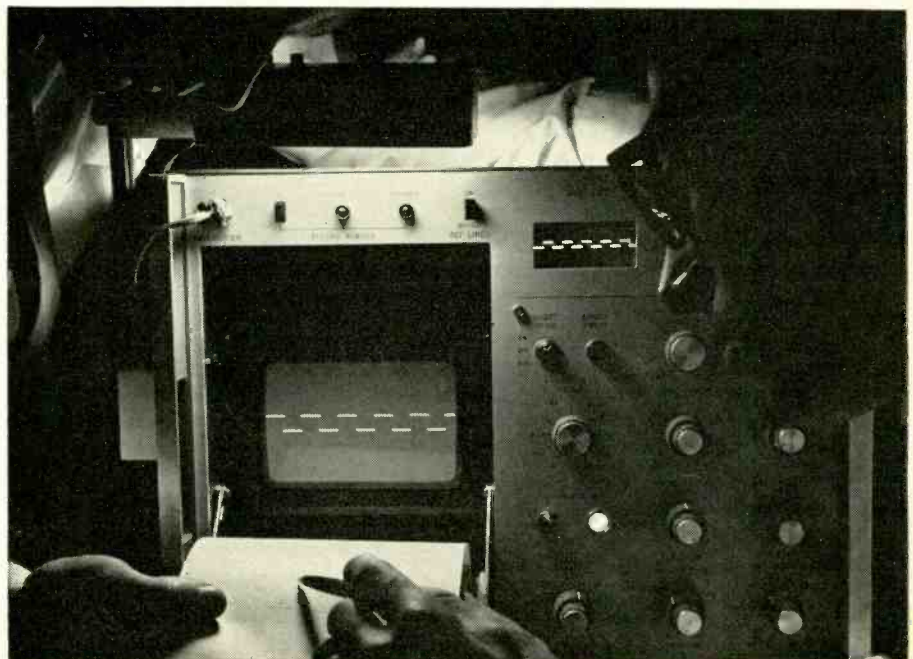

50,000 Men Who Filled Out DeVRY TECH COUPONS

During The Past 36 Years,
Earned Diplomas As Qualified
Electronics Technicians

How about you? If 50,000 men found a DeVry Coupon to be a start toward a new, wonderful world — a world with money-in-the-pocket, job-progress, and a real future — *How about you?* For many of those men were once like you: looking for a good field to get into, or an escape from a get-nowhere, low-income job. Some of them had no previous technical experience or advanced education; others didn't realize they had a talent for electronics! They were astonished, that after completing a few of the interesting experiments and assignments, how simple it all seemed and how interesting. (Some tell us they hated to leave their desks to go to bed!) For DeVry Tech teaches by showing; you learn by doing. Maybe you can come to one of our 2 modernly-equipped resident schools, maybe you'll find it convenient to keep your present job and prepare at home. Thousands of our graduates did one or the other; all had the ambition to go through with it. *How about you?* Mail the coupon for details.

ACCREDITED MEMBER OF NATIONAL HOME STUDY COUNCIL

DeVRY INSTITUTE OF TECHNOLOGY · CHICAGO · CANADA

Circle 9 on reader's service card

DeVRY INSTITUTE OF TECHNOLOGY

4141 Belmont Ave., Chicago, Ill. 60641, Dept. RE-6-X

Please give me your two free booklets, "Pocket Guide to Real Earnings" and "Electronics in Space Travel"; also include details on how to prepare for a career in Electronics. I am interested in the following opportunity fields (check one or more):

- | | |
|--|---|
| <input type="checkbox"/> Space & Missile Electronics | <input type="checkbox"/> Communications |
| <input type="checkbox"/> Television & Radio | <input type="checkbox"/> Computers |
| <input type="checkbox"/> Microwaves | <input type="checkbox"/> Industrial Electronics |
| <input type="checkbox"/> Automation Electronics | <input type="checkbox"/> Broadcasting |
| <input type="checkbox"/> Radar | <input type="checkbox"/> Electronic Control |

NAME _____ AGE _____

ADDRESS _____ APT. _____

CITY _____ ZONE _____ STATE _____

Check here if you are under 16 years of age.

HOME STUDY AND RESIDENT SCHOOL TRAINING
2096 AVAILABLE IN CANADA

Approved for
Veterans

**5,000 FIRMS HAVE
EMPLOYED DeVRY
GRADUATES**

Nearly every industry using electronics in many applications, employs DeVry trained men.

**2,200 RESIDENT
STUDENTS**

Men 18-45, come to our Chicago or Toronto training laboratories, daytime or after work, to prepare for a job in electronics.

EMPLOYMENT SERVICE

Many graduates who started by clipping our coupon are now on the jobs we helped them get; many consult us regularly on technical problems. They are DeVry men! Clip that coupon and join them.

new Sams books

Color TV Servicing Made Easy, Vol. 2



by Wayne Lemons & Carl Babcock. This second volume brings the technician up to date on new color circuitry and developments introduced since the publication of the best-selling first volume. Initial chapters cover the general theory and circuitry of the newer color TV designs. These are followed by service hints and setup procedures for repairing all brands of color receivers, by actual make and model number. The

text is heavily supported by illustrations, including several in full color. 288 pages; 5 1/2 x 8 1/2". Order 20523, only. \$450

Transistor Specifications Manual, Revised

The newly revised and expanded edition of this valuable reference provides the electrical and physical parameters for virtually all the transistors now in use. Electrical data includes maximum collector-to-base, emitter-to-base, and collector-to-emitter voltages; maximum collector current; power dissipation; and maximum operating temperature. Also lists frequency gain and leakage parameters. Special section provides physical data, dimensions, and information required to install each unit; another section identifies leads and terminals for each transistor listed. Indispensable to anyone working with semiconductors. 224 pages; 5 1/2 x 8 1/2". Order 20553, only. \$295

Synchros and Servos

by Training & Retraining, Inc. This programmed text provides the technician with a clear understanding of synchro and servo motor principles, applications, circuitry, operation, maintenance, and troubleshooting. Also covers the theory and operation of discontinuous, continuous, open-cycle, and closed-cycle control systems, to provide the basic background required to work with the more complex servo mechanisms now in wide use; gives detailed maintenance and troubleshooting methods. Includes questions and answers for helpful study and review. 192 pages; 5 1/2 x 8 1/2". Order 20533, only. \$495

North American Radio-TV Station Guide, 4th Ed.

by Vane A. Jones. The latest edition of this widely used guide lists all a-m and f-m radio stations and all television stations in the U.S., Canada, Mexico, and the West Indies. Each station is listed by its geographical location, frequency, call letters, operating power, network affiliation; supplemental information is provided where applicable. 144 pages; 5 1/2 x 8 1/2". Order 20527, only. \$250

Projects in Basic Magnetism

by John Potter Shields. The basic principles of magnetism and electromagnetism are demonstrated graphically and interestingly by means of a series of experiments and projects. These include a demonstration induction heater, spot welder, transformer, a-c induction motor, synchronous motor, magnetic amplifier, etc. Over thirty such experiments are covered, and each is coupled with a clear explanation of the basic magnetic principles involved. Each of the projects is easy to perform; only a few low-cost, readily obtainable components are required. 96 pages; 5 1/2 x 8 1/2". Order 20556, only. \$225

HOWARD W. SAMS & CO., INC.

Order from your Sams Distributor today, or mail to Howard W. Sams & Co., Inc., Dept. RE-6, 4300 W. 62nd Street, Indianapolis, Ind. 46268

Send me the following books:

20523 20533 20556

20553 20527

Send FREE Sams Booklist. \$_____ enclosed

Name _____

Address _____

City _____ State _____ Zip _____

My Distributor is _____

Circle 10 on reader's service card

NEWS BRIEFS continued

the CRT face expose photosensitive paper, thereby providing a permanent record. A second CRT on the front panel monitors the display.

Also shown at IEEE was a vacuum-type fiber-optic faceplate one foot in diameter. It was developed by Mosaic Fabrications to provide a bright radar display in daytime operations.

ELECTRONICS AND THE LAW

During late February the FCC field office in New York City was baffled by a clandestine radio station operating illegally in the 80-meter ham band. Calling itself "Radio Free Harlem," the station transmitted popular music, tapes of religious services, and appeals for contributions to a Harlem church.

Because the bootleg transmitter (operating around 3,800 kHz) stayed on the air only about half an hour at a time, FCC direction finders were unable to pinpoint its exact location. One official suggested the station might be in a car.

One March night, Commission engineers were off on a raid in their own back yard. They caught more than 20 persons illegally operating CB stations in the Washington, D.C. area. Some were unlicensed, but many were simply transmitting without mentioning their call signs—and using code names.

Late in March, agents of the Federal Narcotics Bureau in New York City arrested a 40-year-old importer in his lower Manhattan office. They opened a packing crate containing a shipment of oscilloscopes just received from Paris. Hidden in the equipment was 12 lb of pure heroin worth a quarter of a million dollars.

[Instruments are rumored to be known as DopeScope Model H.]

Finally, the FCC is considering the matter of type acceptance for class-D transmitters in the Citizens Radio Service. At present such CB transmitters are not required to be type accepted, although they may be, at the option of the manufacturer. It's even permissible to construct your own transmitter and have it licensed by the Commission as *composite*.

The FCC has proposed a rule change which would require that all new transmitters be type-accepted. Manufacturers would have to make certain performance tests and submit their data to the FCC for acceptance, before the transmitters could be used on the Citizens band. Furthermore,

Radio-Electronics

154 WEST 14TH STREET
NEW YORK 10011

HUGO GERNSBACK, *editor-in-chief*
M. HARVEY GERNSBACK, *publisher*
FOREST H. BELT, *editor*
Bruce Ward, *production manager*
Robert F. Scott, W2PWC, *senior editor*
Thomas R. Haskett, *managing editor*
Jack Darr, *service editor*
I. Queen, *editorial associate*
Allen B. Smith, *science editor*
Peter E. Suthelm, *audio editor*
Wm. Lyon McLaughlin,

technical illustration director

Maxine Schware, *assistant to editor*
Adelaide Cassity, *production assistant*
G. Aliquo, *circulation manager*
Joseph L. Bund, *newsstand director*

Cover by Harry Schlack

RADIO-ELECTRONICS is published by Gernsback Publications, Inc.

Chairman of the Board: Hugo Gernsback
President: M. Harvey Gernsback
Vice President-Secretary: G. Aliquo

ADVERTISING REPRESENTATIVES

EAST
John J. Lamson,
RADIO-ELECTRONICS, 154 West 14th Street,
New York 10011, 212-255-7755

MIDWEST/N.&S. Car., Ga., Tenn.
Robert Patts, the Bill Patts Co., 4761 West
Touhy Ave., Lincolnwood, Ill. 60646,
312-679-1100

W. COAST/Texas/Arkansas/Oklahoma
J. E. Publishers Representative Co., 8380
Melrose Ave., Los Angeles, Calif. 90069,
213-653-5841; 420 Market St., San Francisco,
Calif. 94111, 415-981-4527

UNITED KINGDOM
Publishing & Distributing Co., Ltd., Mitre
House, 177 Regent St., London W.1, England

SUBSCRIPTION SERVICE: Send all subscription correspondence and orders to RADIO-ELECTRONICS, Subscription Department, Boulder, Colo. 80302. For change of address, allow six weeks, furnishing both the old and new addresses and if possible enclosing label from a recent issue.

MOVING?

Or writing about subscription? Be sure to fill out form below.
For FASTEST service on address change, missing copies, etc., attach old mailing label in first space below. Otherwise please print clearly your address as we now have it.

OLD ADDRESS (Attach old label if available)

Name

Address

City State

Zip Code

NEW ADDRESS

Name

Address

City State

Zip Code

Mail to: RADIO-ELECTRONICS
Subscription Dept. Boulder, Colo. 80302

A New Electronics Slide Rule with Self-Training Course

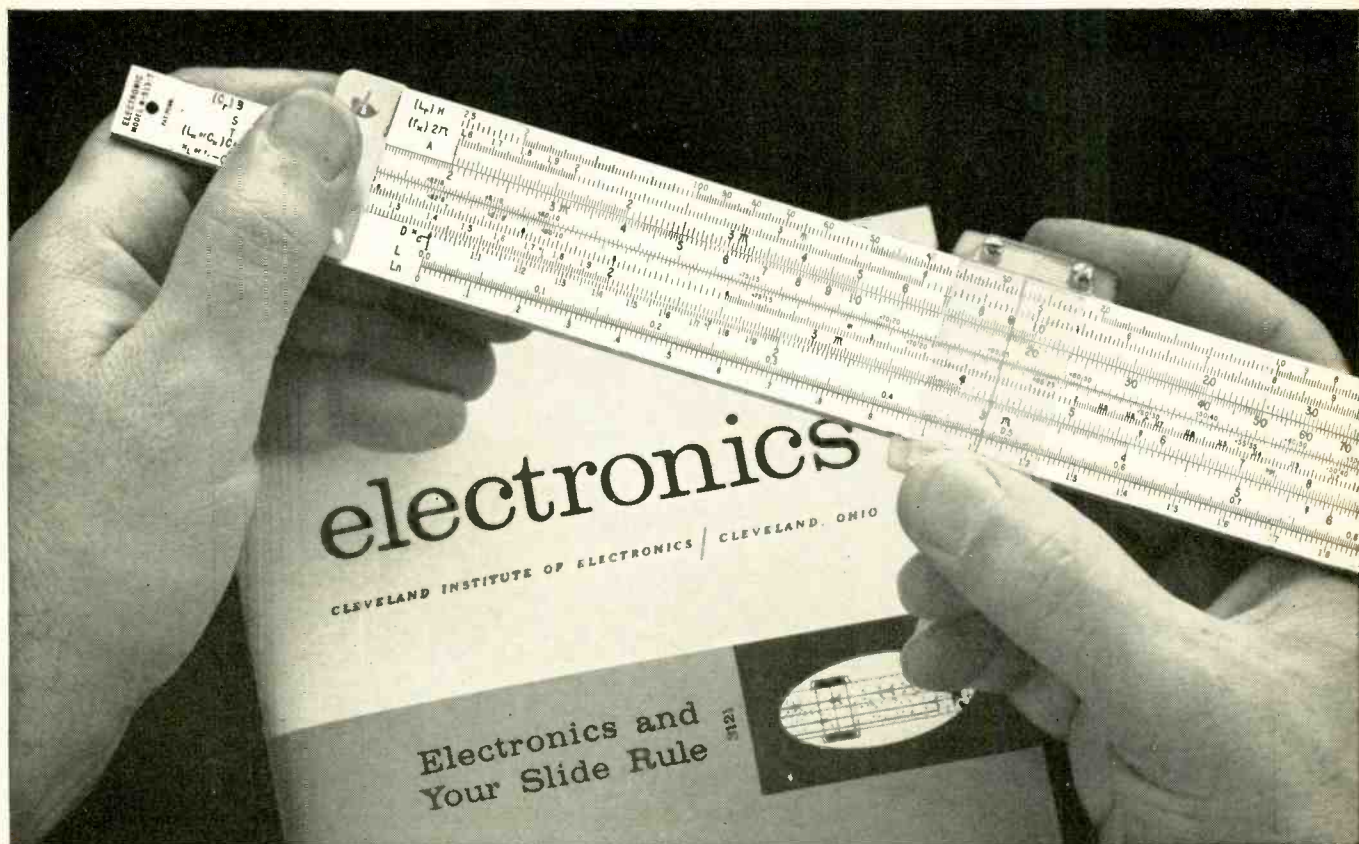

Why didn't someone think of this before?

Here's a great *new* way to solve electronic problems accurately . . . easily. The Cleveland Institute Electronics Slide Rule* is the only rule designed specifically for the exacting requirements of electronics computation. It comes complete with an illustrated Instruction Course consisting of four AUTO-PROGRAMMED* lessons . . . each with a short quiz you can send in for grading and consultation by CIE's expert instructors. With this personal guidance, you'll soon be solving complex electronics problems in seconds while others still struggle along with pad and pencil.

Here's what Mr. Joseph J. DeFrance, Head of the Electrical Technology Dept., New York City Community College, has to say about it:

"I was very intrigued by the 'quicke' electronics problem solutions. It is an ingenious technique. The special scales should be of decided value to any technician, engineer, or student. The CIE slide rule is a natural."

See for yourself. Learn how to whip through all kinds of reactance, resonance, inductance, AC and DC circuitry problems in seconds . . . become a whiz at conventional computations too!

This all-metal 10" rule is made to our tough specs by Pickett, Inc. . . . comes complete with top grain leather carrying case and Instruction Course. A \$50 value for less than \$25. Send coupon for FREE illustrated booklet and FREE Pocket Electronics Data Guide. Cleveland Institute of Electronics, 1776 E. 17th St., Dept. RE-141, Cleveland, Ohio 44114.

*TRADEMARK

GET BOTH FREE!

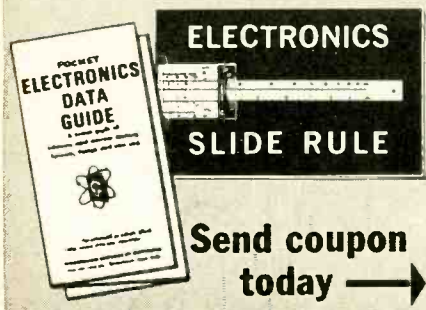

Cleveland Institute of Electronics

1776 E. 17th St., Dept. RE-141 • Cleveland, Ohio 44114

Please send FREE Electronics Slide Rule Booklet.
SPECIAL BONUS: Mail coupon promptly . . . get FREE Pocket Electronics Data Guide too!

Name _____ (Please Print)

Address _____ County _____

City _____ State _____ Zip _____

A leader in Electronics Training . . . since 1934

EXPERIENCE IS STILL YOUR BEST TEACHER

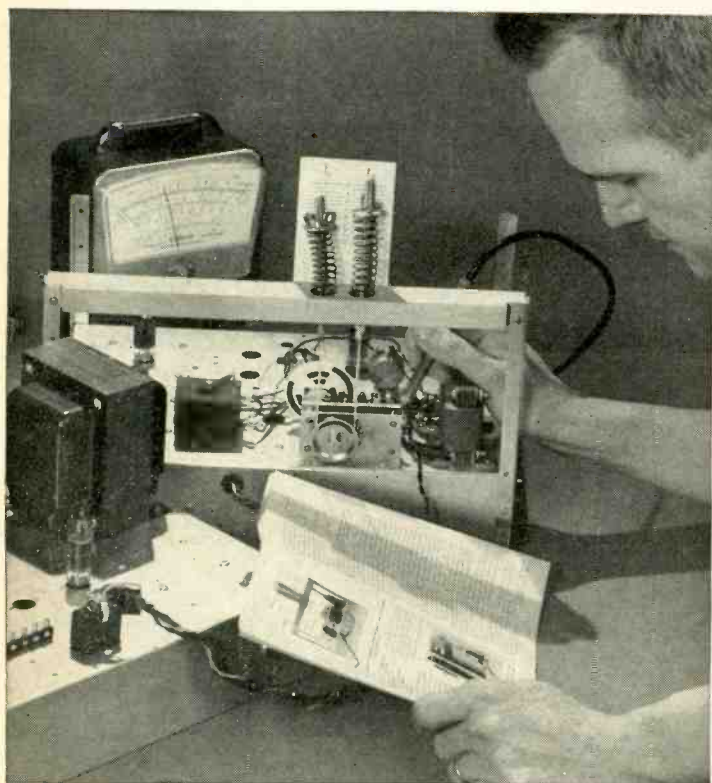

That is why NRI has invested more in Professional Lab Equipment than all other home-study schools combined. It makes training

at home in Electronics fast and fascinating. Your hands are trained as well as your head.



OLDEST AND LARGEST
SCHOOL OF ITS KIND

Accredited by the Accrediting Commission of the National Home Study Council

You get more for your money from NRI

—more value, more solid experience so essential to careers in Electronics. NRI's pioneering "discovery" method is the result of more than half a century of simplifying, organizing, dramatizing subject matter. In each of NRI's major courses you learn by doing. You demonstrate theory you read in "bite-size" texts programmed with NRI designed-for-learning professional lab equipment. Electronics comes alive in a unique, fascinating way. You'll take pleasure in evidence you can feel and touch of increasing skills in Electronics, as you introduce defects into circuits you build, perform experiments, discover the "why" of circuitry and equipment operation.

Almost without realizing it, the NRI discovery method gives you the professional's most valuable tool—practical experience. You learn maintenance, installation, construction and trouble-shooting of Electronic circuits of any description. Whether your chosen field is Industrial Electronics, Communications or TV-Radio Servicing, NRI prepares you quickly to be employable in this booming field or to earn extra money in your spare time or have your own full-time business. And you start out with training equivalent to months—even years—of on-the-job training.

NRI Has Trained More Men for Electronics Than Any Other School

—By actual count, the number of individuals who have enrolled for Electronics with NRI could easily populate a city the size of New Orleans or Indianapolis. Over three-quarters of a million have enrolled with NRI since 1914. How well NRI training has proved its value is evident from the thousands of letters we receive from graduates. Letters like those excerpted below. Take the first step to a rewarding new career today. Mail the postage-free card. No obligation. No salesman will call. NATIONAL RADIO INSTITUTE, Electronics Division, Washington, D.C. 20016.



L. V. Lynch, Louisville, Ky., was a factory worker with American Tobacco Co., now he's an Electronics Technician with the same firm. "I don't see how the NRI way of teaching could be improved."



G. L. Roberts, Champaign, Ill., is Senior Technician at the U. of Illinois Coordinated Science Laboratory. In two years he received five pay raises. Says Roberts, "I attribute my present position to NRI training."



Don House, Lubbock, Tex., went into his own Servicing business six months after completing NRI training. This former clothes salesman just bought a new house and reports, "I look forward to making twice as much money as I would have in my former work."



Ronald L. Ritter of Eatontown, N.J., received a promotion before finishing the NRI Communication course, scoring one of the highest grades in Army proficiency tests. He works with the U.S. Army Electronics Lab, Ft. Monmouth, N.J. "Through NRI, I know I can handle a job of responsibility."

APPROVED UNDER NEW GI BILL. If you served since January 31, 1955, or are in service, check GI line on postage-free card.

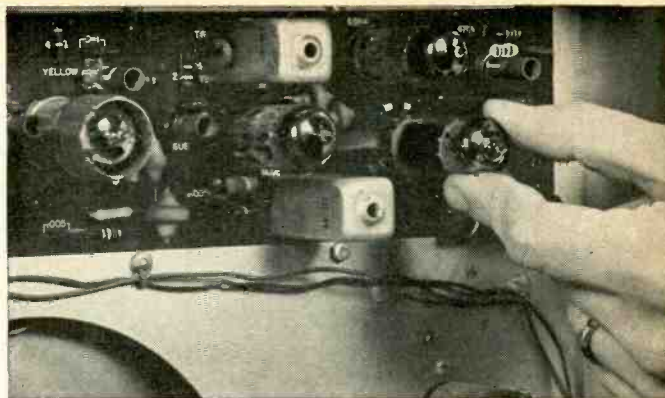

COLOR TV CIRCUITRY COMES ALIVE

as you build, stage-by-stage, the only custom Color-TV engineered for training. You grasp a professional understanding of all color circuits through logical demonstrations never before presented. The TV-Radio Servicing course includes your choice of black and white or color training equipment.

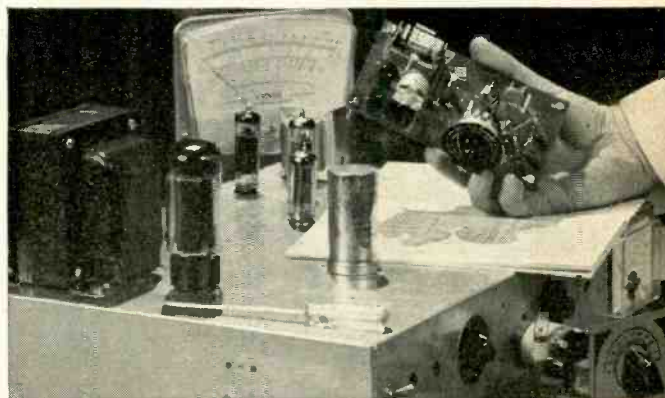

COMMUNICATIONS EXPERIENCE

comparable to many months on the job is yours as you build and use a VTVM with solid-state power supply, perform experiments on transmission line and antenna systems and build and work with an operating, phone-cw, 30-watt transmitter suitable for use on the 80-meter amateur band. Again, no other home-study school offers this equipment. You pass your FCC exams—or get your money back.

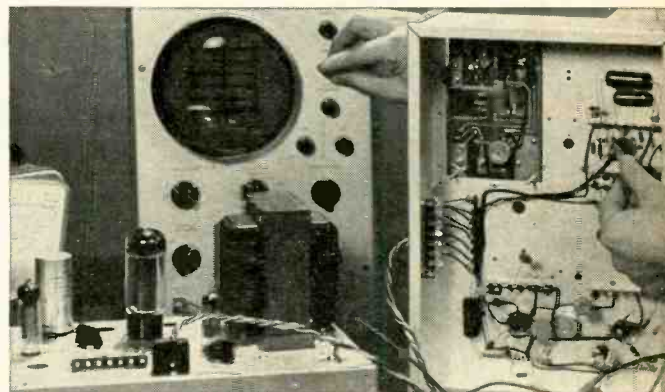

COMPETENT TECHNICAL ABILITY

can be instantly demonstrated by you on completing the NRI course in Industrial Electronics. As you learn, you actually build and use your own motor control circuits, telemetering devices and even digital computer circuits which you program to solve simple problems. All major NRI courses include use of transistors, solid-state devices, printed circuits.

FIRST AND ONLY compact SCRULOX® screwdriver sets

Increasing use of Scrulox square recess screws in appliances, radios, TV sets, electronic instruments... even the control tower at Cape Kennedy... has created a need. A need for compact, versatile driver sets. Small enough to tuck in a pocket. Complete enough to be practical on shop bench or assembly line.

Now, here they are... from Xcelite, of course.



PS44
COMPACT
CONVERTIBLE SET

Five color coded midget Scrulox drivers—#00 thru #3

One midget nutdriver—1/4" hex "Piggyback" torque amplifier handle increases reach and driving power

See-thru plastic case doubles as bench stand



99SL
INTERCHANGEABLE
BLADE KIT

Five Scrulox blades—#00 thru #3
Shockproof, breakproof, Service Master handle
Durable, see-thru plastic case



XCELITE, INC., 10 BANK ST., ORCHARD PARK, N. Y.
Circle 12 on reader's service card

NEWS BRIEFS continued

after five years, no non-type-accepted transmitters would be permitted on class-D frequencies.

The Commission's proposal also included a requirement for a modulation limiter in new transmitters. [Hooray!—Editor]

LOW-COST WEATHER PHOTOS BY SATELLITE

The ESSA and Nimbus meteorological satellites have been in position for some time now, transmitting weather pictures for the use of anyone with the proper receiving equipment. Up to now, such gear has been quite expensive.

Now the cost has been reduced, and colleges and small weather stations should be able to afford receiving equipment. The EMR Photo Receiver (see photo below) developed by Aerospace Sciences Division of Electro-Mechanical Research, Inc., costs from \$3,500 to \$5,000.

The unit displays received pictures on a high-resolution CRT face, where the image is recorded on a Polaroid camera. Up to 15 pictures per day can be taken.

BUSINESS OUTLOOK

Sales of electronic products—like nearly everything else—are changing. There's a noticeable shift in buying patterns today. Color TV, 3-year star of the electronics boom, is faltering. Moving into the limelight is a new glamor contender: cartridge tape.

Another trend in audio is the shift toward systems that blend with room decor—particularly speakers. Tie-ins between audio-components makers and interior designers are giving hi-fi sales a shot in the arm.

Many US electronics corporations are moving their manufacturing operations overseas. This is a result of the tight labor situation in the US. Workers in other countries seem to be more willing to accept new technologies and automated production. Often, there are tax advantages that can't help attracting large corporations.

Recent over-the-border shifts are to Taiwan, Mexico, and to Puerto Rico. Take the last: More than 50 US electronics corporations have plants on this sunny Caribbean island. Special tax advantages, willing labor, attractive climate—all combine to draw even more firms. Radio Corporation of America is a recent migrant, with its new RCA de Puerto Rico, Inc. facility at Juncos, P.R. The new plant makes tricolor guns for color picture tubes. One RCA executive commended the quality of work done by its labor force—predominantly Puerto Rican women. END

Lab-Type Tone-Burst Generator

Introducing a versatile test instrument new to many readers. IC modules simplify construction. Details in July **RADIO-ELECTRONICS**



we looked into your future, then created the "little corporal," a most remarkable CRT tester.

B & K has done it again . . . put you a "jump ahead" by looking into your future . . . your problems, *your* needs. This is the "Little Corporal," the CRT Rejuvenator and Checker, designed to provide maximum obsolescence protection by providing continuously variable voltages for all CRT elements. You can make the most accurate possible tests, even on future CRT types, because the heater

voltage is metered and is continuously variable from 0 to 13 volts with any tube heater current. And, using the required adaptors, you can test and correct all tube, transistor or integrated circuit black and white and color picture TV tube troubles (including GE 11" color and imported color tubes) in a few minutes . . . in the home or on the bench . . . without removing tubes from the TV set.

You can give new life to weak or in-operative picture tubes—prove to your customers their need for new tubes.

The "Little Corporal," another product of B & K electronic innovation, carries the B & K Professional Servicing Equipment emblem, your assurance . . . your customers' assurance . . . that you use the finest equipment made.

Model #465, Net: \$89.95.



A Division of
Dynascan Corporation
1801 W. Belle Plaine
Chicago, Illinois 60613

Export: Empire Exporters, Inc.
123 Grand Street
New York, N.Y., 10013



A Division of Dynascan
Where Electronic Innovation
Is A Way of Life

Circle 13 on reader's service card

Pick up Special Channels on ANY radio with MINIVERTER II.

Listen to **AIR TRAFFIC, POLICE**
or **FIRE DEPT. CALLS, COAST**
GUARD WEATHER, AMATEUR
or any other special frequency
you specify.



In seconds, convert any car radio to a sensitive VHF FM/AM receiver . . . without modifying the radio . . . without using extra wires . . . without soldering . . . without special antennas. Available for high band 108-170 mc or low band 30-50 mc reception. Each unit tuneable over a 1.0 mc range.

Installation of basic unit is easy and foolproof. Adjustable automatic squelch circuitry (included) is quickly installed by adding two wires to radio, giving full squelch capability at no additional cost. Unit measures 3" high and is unconditionally guaranteed if installed and used properly. Instructions for home radio installation included with each unit. Brochure on request.

only \$29⁹⁵ complete

I enclose check/money order (No COD's)
 _____ MINIVERTER II UNIT(s) @ \$29.95 ea.
 _____ mc, exact frequency desired.
 _____ send free brochure.
 Name _____
 Street _____
 City _____
 State _____ Zip Code _____

SCIENTIFIC ASSOCIATES CORPORATION
BOX 276, S. GLASTONBURY, CONNECTICUT
 Telephone 203-633-1971

Circle 14 on reader's service card

Correspondence

TRIGGERS FOR SERVICE SCOPES

Dear Editor:

Mr. Allen's article "Triggered Scope for Color" in your January 1967 issue brings up a point: Why don't service-equipment manufacturers offer a triggered-sweep attachment for use with their better scopes? The late Tom Jaski described such a device in the September 1956 RADIO-ELECTRONICS. This was a package of triggered sweep and time-delay generator.

HARRY VELME

Denver, Colo.

ALWAYS A BETTER WAY?

Dear Editor:

Not having seen the "Lights-on Reminder for Your Car" article in the December RADIO-ELECTRONICS, I don't know what Mr. Necker (Correspondence, March 1967) was trying to correct, but his answer is hardly foolproof. If the breaker points in the distributor happen to be open, that buzzer might better be hooked up to the back-porch door because it sure isn't going to do much buzzing in his circuit.

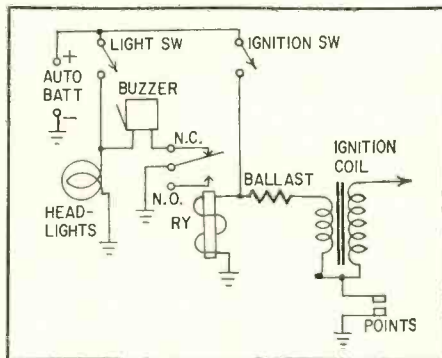

Granted, the breaker points are more likely to be closed than open, but for reliability I prefer an spdt relay (see diagram). The buzzer circuit is disarmed when the ignition switch is on, because the relay armature pulls over to the normally open contact and the buzzer has no ground return. With the ignition switch off, the relay contacts ground the buzzer, which will sound if the headlight switch is on.

RODERIC SPENCER

Plainfield, N. J.

EUROPEAN RADIO AND TV

Dear Editor:

Two items in the January 1967 issue of R-E are erroneous.

A News Briefs item stated that Great Britain was about to start a new popular music service with commercials, in contrast to the 44-year-old BBC, the "government-controlled monopoly that has furnished Britons with commercial-free radio fare until now." The BBC will provide a popular music programme from 5:30 am-7:30 pm and 10 pm-2 am on 1214 kHz. This programme, however, will not contain advertising commercials.

Despite a popular misconception in the US, the BBC is neither government operated nor financed. Also, it doesn't have a monopoly of the air in Britain. Continental European stations beam commercial transmissions to Britain, and the independent commercial *Radio Manx* on the Isle of Man is licensed by the British Post Office.

On page 43 ("What Happened at Oslo?") you list the United Kingdom as using the 625-line CCIR TV standards, whereas the BBC actually uses the 625-line standards called "Irish" in your chart. The Irish standards are used in the Republic of Eire, not in the North of Ireland, which uses the British 405-line standards.

Also, you show Belgium and Tunisia using 819-line French standards. Both countries have switched to 625 lines.

ALAN F. REEKIE

London
Great Britain

[Errors, errors! Yes, we struck out on the proposed commercial radio service—but it was seriously considered in Great Britain.

From an American point of view, the BBC seems government-controlled and operated, analogous to our Voice of America. Perhaps it's technically an independent, autonomous entity. But its payroll derives from government-collected tax money. We must admit we never heard of commercial Radio Manx; the continental stations aren't subject to British jurisdiction, hence can hardly be pertinent to this discussion.

You're correct—the BBC's 625-line standards are their own, not the same as CCIR's. True, Belgium and Tunisia don't use 819 lines any more. But even in this world of instant communication via satellites, it's difficult to keep reference material up to date every day.

We used the name "Ireland" because few Americans would recognize its proper designation—the Republic of Eire.—Editor]

END

“Sure,
you work hard,
but that’s not
enough...”

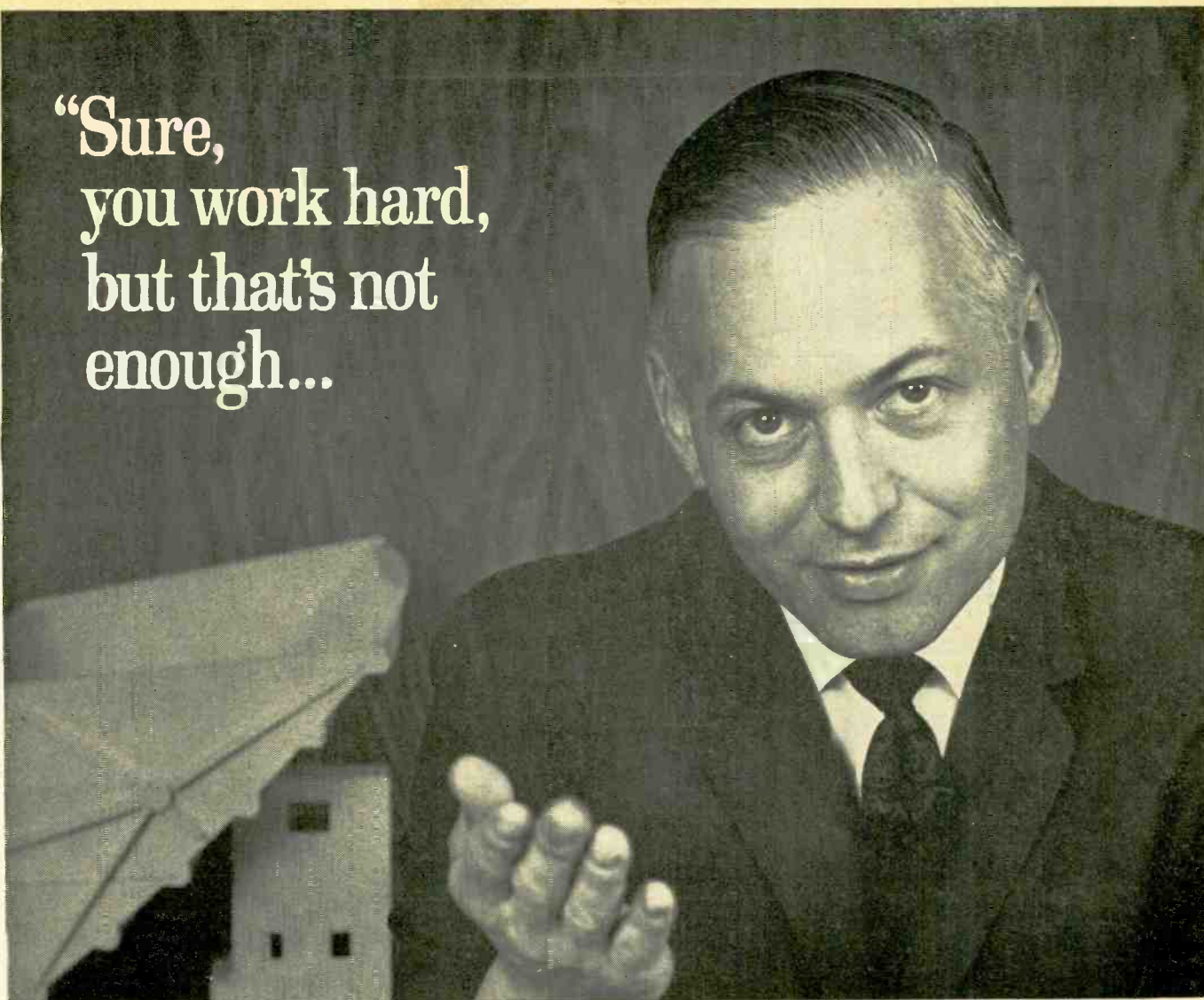

...you need more education to get ahead in electronics”

No matter how hard you work, you can't really succeed in electronics without advanced, specialized technical knowledge.

Going back to school isn't easy for a man with a full-time job and family obligations. But CREI Home Study Programs make it possible for you to get the additional education you need without attending classes. You study at home, at your own pace, on your own schedule.

CREI Programs cover all important areas of electronics including communications, servomechanisms, even spacecraft tracking and control. You're sure to find a program that fits your career objectives.

You're eligible for a CREI Program if you have a high school education and work in electronics. Our FREE book gives all the facts. Mail coupon or write: CREI, Dept. 1406E, 3224 Sixteenth St., N.W. Washington, D.C. 20010



SEND FOR FREE BOOK



Accredited Member of the National Home Study Council

The Capitol Radio Engineering Institute

Dept. 1406E, 3224 Sixteenth Street, N.W.
Washington, D.C. 20010

Please send me FREE book describing CREI Programs. I am employed in electronics and have a high school education.

NAME _____ AGE _____

ADDRESS _____

CITY _____ STATE _____ ZIP CODE _____

EMPLOYED BY _____

TYPE OF PRESENT WORK _____ GI BILL

- I am interested in Electronic Engineering Technology
 Space Electronics Nuclear Engineering Technology
 Industrial Electronics for Automation
 Computer Systems Technology

APPROVED FOR VETERANS ADMINISTRATION TRAINING



**Commercial Sound
Speaker Source...**



You never compromise with fidelity or quality when you specify Oxford on all your speaker needs.

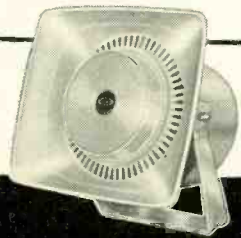

That's because Oxford electronic and sound engineers know that specialized applications require specialized developments. Oxford doesn't produce just horn or cone types. Oxford studies the application and the problem develops specific units for specific needs. You're never stuck with trying to pour a bushel basket into a pint measure. Paging and talk-back horns, outdoor hi-fi systems, P.A. systems and other commercial sound installations all find the perfect speaker for the system at Oxford.

Visit display Room 509-A June 19th through 21st Conrad Hilton Hotel, Chicago.



Match your skills with the Oxford line of speakers that bring out the best in every sound installation. Write for the Oxford catalog of "speakers for every purpose" today!

OXFORD TRANSDUCER COMPANY
A Division of Oxford Electric Corporation
3911 S. Michigan Ave.
Chicago, Ill. 60653

In the Shop... With Jack

by JACK DARR

IF YOU FIND WEAK COLOR BUT A CLEAR picture, check the TV set first, of course. Age trouble can cause just such symptoms, as well as a few others. But, if the problem shows up on only one channel, look out! It could be station trouble, but it might not be. You can crosscheck with other sets in the same neighborhood to verify.

A while back I found weak color on only *one* channel of a receiver working off a CATV system. And the set had been delivering pretty good color. Sound puzzling? I found the trouble in a new high-gain single-channel preamplifier, just installed on that channel. The gain increased, but the color suddenly got very weak!

dip. This is the villain! Crosschecking, on the original response, and after flattening the top of the curve, as in Fig. 2, showed that even this apparently slight loss in the color subcarrier amplitude would definitely affect the color signal on a shop monitor TV.

So, there it was. The dip was causing a change in the *amplitude ratio* between the R-Y/B-Y signal and the Y signal (video). Since the Y carrier is a *part* of the R-Y/B-Y signal—a factor in it—if you change that ratio you change the color amplitude! The proof of the pudding was in the eating. Flattening the top of the curve cleared up the trouble.

This case was an oddball, of course. You won't find such things in ordinary home antenna systems. There is, however, always the possibility of finding them in CATV systems, master antenna systems in hotels or apartments, or in the larger home antenna distribution systems, *if* single-channel preamps are used at the antenna. This one had been installed at the head end, between the antenna and the first broadband line amplifier.

Frankly, I doubt very much if it would be possible for any *broadband* amplifier to cause this kind of trouble. This includes the modern all-channel antenna boosters, home distribution systems, CATV and master antennas, and any kind of good quality all-channel equipment. To get such a symptom, the response curve would have to have a very sharp *notch* in it, exactly on the color subcarrier frequency for the channel affected. It would look somewhat

Continued on page 22

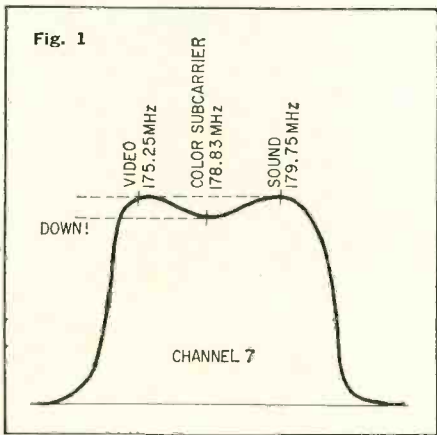

Checking the preamp, I found it had plenty of gain; bandwidth was fine, and so on. But a sweep generator through the preamp produced a response curve that looked like Fig. 1.

Notice that the video and sound carriers are on the tops of the saddleback, but the color subcarrier is in the

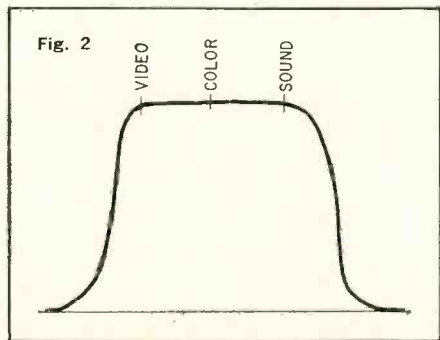

This column is for your service problems—TV, radio, audio or general and industrial electronics. We answer all questions individually by mail, free of charge, and the more interesting ones will be printed here.

If you're really stuck, write us. We'll do our best to help you. Don't forget to enclose a stamped, self-addressed envelope. Write: Service Editor, Radio-Electronics, 154 West 14th Street, New York 10011.

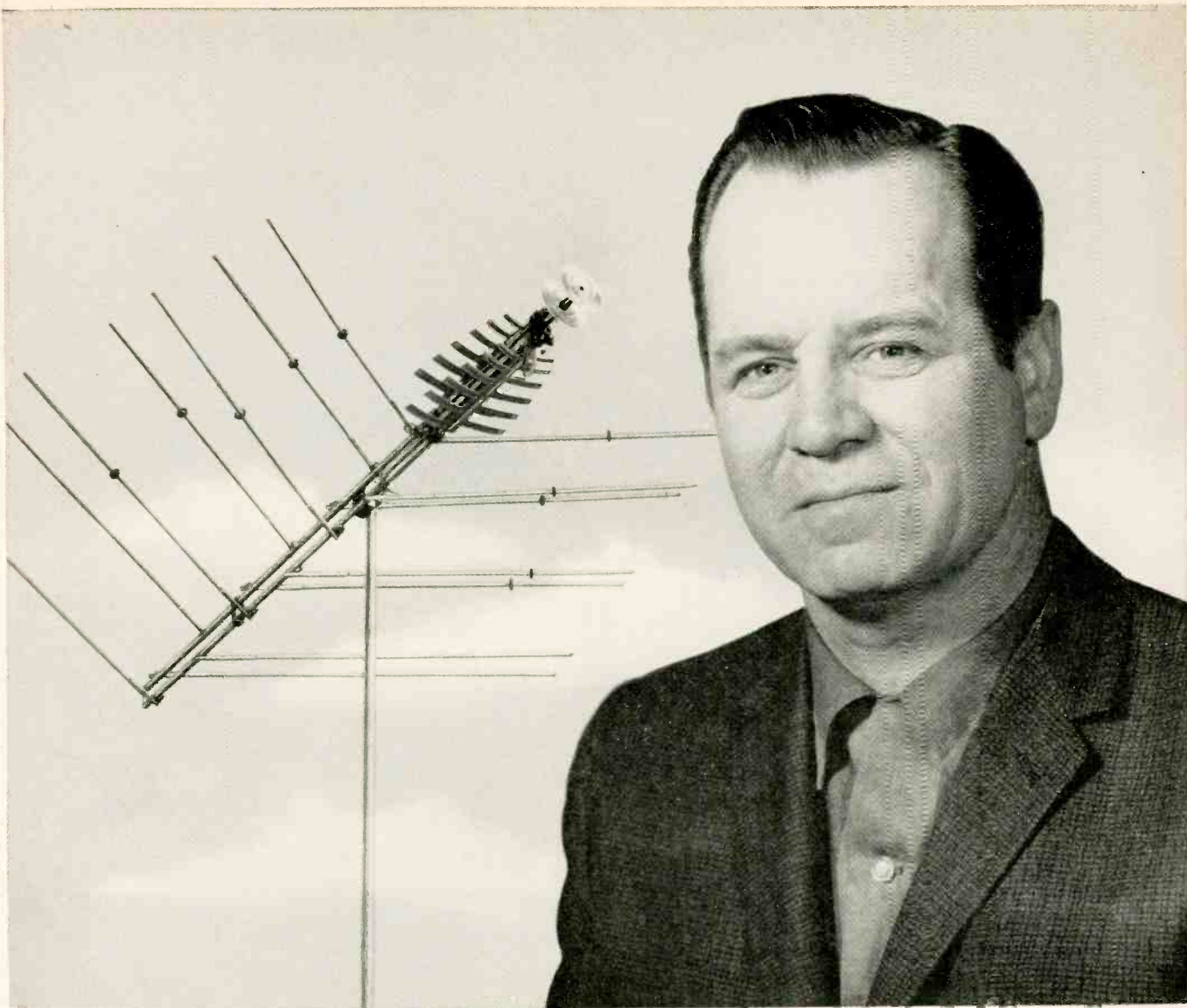

“Out here in the fringes, your reputation depends on the pictures you deliver...”

That’s why we stick to JFD Color Laser antennas,” affirms HARRY MELANDER, of Melander’s Appliance Center, Alta, Iowa.

“The nearest TV stations to us are channels 4 and 9 from Sioux City, over 60 miles away and channel 21 from Fort Dodge, some 70 miles away in the opposite direction. And on their way here the signals have to get through some heavily wooded hills. This makes it real easy for snow and ghosts to creep into the pictures—especially in color.

“We rely on JFD LPV antennas exclusively because they always come through with reception that’s ghost-

free and color-true—despite this distance and terrain.”

Harry Melander depends on both LPV-TV Log Periodics and Color Lasers—like other professionals—to deliver the performance his customers expect from a professional.

Here’s why:

W-I-D-E BAND LPV LOG PERIODIC DESIGN delivers *more gain, higher signal-to-noise ratios, pinpoint directivity* that kills ghosts—VHF and UHF.

SHOWROOM QUALITY COLOR—flat response across each channel. No “suck-outs” or “roll-off.” *Out-performs* any other antenna in *color* or *black/white*—keeps customers sold.

CAPACITOR-COUPLED ELEMENTS work on *both* fundamental and harmonic modes. *Entire* antenna (not just part of it as in other antennas) responds to *every* channel.

RUGGED NEW “FLIP-LOK” ASSEMBLY snaps out elements—keeps them *tight* and right on target.

Switch to the JFD LPV—the professional’s antenna • Your JFD LPV distributor can prove it to you!

JFD®

JFD ELECTRONICS CO.

15 Avenue at 62 Street, Brooklyn, N.Y. 11219

JFD International, 64-14 Woodside Ave., Woodside, N.Y. 11377 JFD Canada, Ltd., Ontario, Canada
JFD de Venezuela, S.A., Avenida Los Haticos 125-97, Maracaibo, Venezuela

LICENSED UNDER ONE OR MORE OF U.S. PATENTS 2,958,081; 2,985,879; 3,011,168; 3,108,280; 3,150,376; 3,210,767; RE. 25,740 AND ADDITIONAL PATENTS PENDING IN U.S.A. AND CANADA. PRODUCED BY JFD ELECTRONICS CO. UNDER EXCLUSIVE LICENSE FROM THE UNIVERSITY OF ILLINOIS FOUNDATION. LICENSED UNDER ONE OR MORE OF U.S. PATENTS 2,955,287 AND 3,015,821 AND ADDITIONAL PATENTS PENDING.

Circle 17 on reader’s service card

TAKE THE FIRST BIG STEP TOWARD A REWARDING CAREER IN ELECTRONICS

Mail card to RCA Institutes today

Thousands of well paid jobs for
Electronics Technicians are
unfilled now

*RCA Institutes Can Train You—
At Home—And Help You Qualify
For This Work*

It's a sad, but true, fact that today, with so many men yearning for better jobs and better incomes, thousands of well paid jobs are unfilled in the vast electronics industry.

Many of the men who could fill these jobs—that is, men with the aptitude and native interest to enjoy a career in electronics—are handicapped because for one reason or another they have not had the opportunity to train themselves for these lucrative positions.

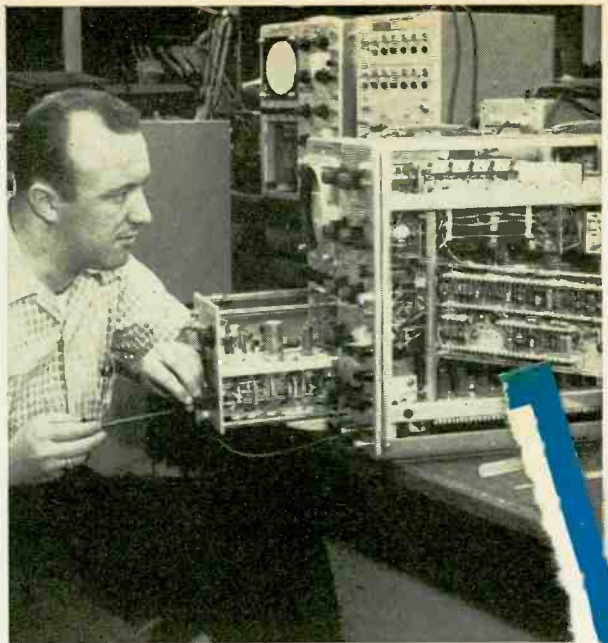

Thousands of well paid jobs for men skilled in electronics are unfilled now

RCA INSTITUTES CAN TRAIN YOU —AT HOME—AND HELP YOU QUALIFY FOR JOBS LIKE THESE!

Every Sunday—and most week days —you will find *The New York Times*, *The Houston Chronicle*, *The Los Angeles Times* and many, many other newspapers cram-full of ads like these. Actively seeking qualified men for jobs in electronics and related fields.

Many of the men who *could* qualify for these jobs—well paid jobs—that is, men with the aptitude and native interest to enjoy a career in electronics—are handicapped because for one reason or another they have not had the opportunity to train themselves for jobs like these.

NOW—THANKS TO RCA INSTITUTES HOME STUDY—YOU CAN TRAIN FOR A CAREER IN ELECTRONICS

Realizing that thousands of technical jobs—well paid jobs—in electronics are or will be available, RCA Institutes has done something positive about the problem. To help sincerely interested men to get started toward a well-paid electronics job, RCA offers an ideal home training program!

HOME STUDY CAN PROVIDE CAREER OPPORTUNITIES!

To help meet the need for qualified men in the electronics field, RCA Institutes has created a wide variety of Home Training Courses, all geared to a profitable, exciting electronics career in the shortest possible time. Included are exclusive "Career Programs" designed to train you quickly for the job you want! Your study program is supervised by RCA Institutes experts who work with you, help

guide you over any "rough spots" that may develop along the way.

OFF TO A FLYING START WITH AMAZING RCA "AUTOTEXT" METHOD

Each "Career Program" starts with the amazing "AUTOTEXT" Programmed Instruction Method—the new, faster way that's almost automatic! "AUTOTEXT" helps even those who have had trouble with conventional learning methods in the past. It is truly the "Space Age" way to learn everything you need to know with the least amount of time and effort.

RCA INSTITUTES ENGINEERED KITS SPEED YOUR PROGRESS

To speed you on your way to a successful electronics career, your "Career Program" will include a variety of RCA Institutes engineered kits at no extra cost—each complete in itself. As a bonus, you will also receive and build a valuable Oscilloscope. You'll get the new Programmed Electronics Breadboard for limitless experiments, including building a working signal generator and a fully transistorized superheterodyne AM receiver and Multimeter.

CHOOSE YOUR CAREER PROGRAM NOW

To get started today on the electronics career of your choice, look over this list of RCA Institutes "Career Programs", pick the one that appeals most to you, and check it off on the attached card:

- Television Servicing
- Telecommunications
- FCC License Preparation
- Automation Electronics
- Automatic Controls
- Digital Techniques
- Industrial Electronics
- Nuclear Instrumentation
- Solid State Electronics
- Electronics Drafting

To meet other specific needs, RCA Institutes also offers a wide variety of separate courses which may be taken separately from the "Career Programs". Those range from Electronics Fundamentals to Computer Programming. They are described in the material you receive.

ADVANCED TRAINING TOO

If you are already working in electronics or have some experience but want to move on up, you may start RCA Institutes training at an advanced level. No tedious repetition of work you already know!

UNIQUE TUITION PLAN

With RCA Institutes, you learn *at your own pace*, and you pay only as you learn. There are no long term contracts to sign . . . no staggering down-payments to lose if you decide to stop . . . no badgering bills. You pay for lessons only as you order them, and should you decide to interrupt your training at any point, you may do so and not owe one cent.

CLASSROOM TRAINING AVAILABLE

RCA Institutes Resident School is one of the largest schools of its kind in New York City with classroom and laboratory training available in day or evening sessions. Coeducational classes start four times a year. Just check "Classroom Training" on the attached card for more details.

FREE PLACEMENT SERVICE, TOO!

In recent years, 9 out of 10 Resident School students who used the Free Placement Service have been placed before or shortly after graduation. This service is now available to Home Study students.

SEND ATTACHED POSTAGE PAID CARD TODAY FOR COMPLETE INFORMATION. NO OBLIGATION FOR FREE BOOK AND DETAILS. NO SALESMAN WILL CALL.

RCA INSTITUTES, Inc., Dept. RE-67
350 West 4th Street,
New York, N. Y. 10014



The Most Trusted Name in Electronics

**N
NO CROSS TALK**

**C
NO DOUBLE TALK
NO DOUBLE TALK**

**R
NO BACK TALK
NO BACK TALK**

**S
sonotone's
new dynamic
cardioid microphone
for home recordings**

... eliminates distortion, background noises, boominess as no other tape microphone can.

Are unwanted sounds spoiling your home tape recordings? Has everyday household noise got you down? Sonotone has the unidirectional answer. It's our new CDM80 dual impedance microphone.

Just 5½ inches high and 1¼ inches in diameter at the top, this Sonotone microphone features the discriminating cardioid pattern that professional performers prefer. Captures every word, note and nuance directed into it, while suppressing extraneous, distracting noises, boominess and feedback. Yet it does not restrict your movements or introduce false tonal variations.

Complete with on-off switch, 15-foot cable and shield. Impedances of 200 ohms and 50K ohms.

Price: \$43.50



**ELECTRONIC APPLICATIONS DIVISION
SONOTONE CORPORATION • Elmsford, N.Y. 10523**
Exports: Singer Prods. Co., NYC. Cable: Exregnis, N.Y.

Write TODAY for Latest Catalog on Sonotone Microphones

Circle 24 on reader's service card

In the Shop . . . With Jack

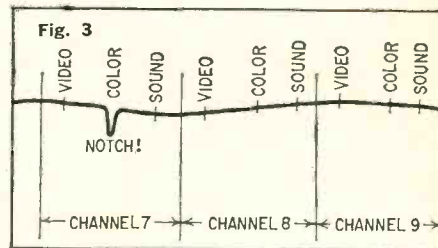

like the notch in channel 7 in Fig. 3.

With present construction methods, it would take something awfully odd for this to happen. I've investigated a good many complaints of "color trouble on the cable," and found them to be completely groundless in all cases (no pun intended!). This is simply because of the comparatively flat and very wideband response of the line amplifiers used.

In fact, at one time I spent several hours trying to make such a notch in the response of these amplifiers. I wanted to find any possible way that it could happen. I couldn't. Not that it can't be done, but I couldn't do it, and I was trying to.

So, if you find weak color on a single channel, and the set does very well on the others, check the antenna system. I've heard the one about the Yagi antenna being so sharp that it chops off the color, but to be honest with you I have never seen an actual case of it. Once again, I'll not say that it can't happen; I've been around too long for that. I've never seen it, that's all.

Now, I have seen a simple thing like a coiled lead-in cut out color, so watch out. Takes only one turn of just the right size. Try it, sometime; it's fascinating!

Transistor power supply

I build the T-40-40 amplifier (in RADIO-ELECTRONICS, March 1965), and it works beautifully, but I've got one problem. The output rises steadily after I turn it on. The power supply voltages jump to the correct level immediately, then gradually rise. Both outputs rise, and the potential between them stays steady at 30 volts each. The Zeners stay right where they ought to be (33 volts). The collector-emitter voltage of Q3 rises (toward negative) steadily—and this seems to explain the rise, but where is it coming from? I've replaced a slightly leaky filter, C2, which seemed to help for a while.—R. L. S., West Babylon, N. Y.

This sounds very much like a transistor leakage problem, and a thermal one. I'd be inclined to suspect that changing voltage across Q3. It may be

Help stamp out blue people

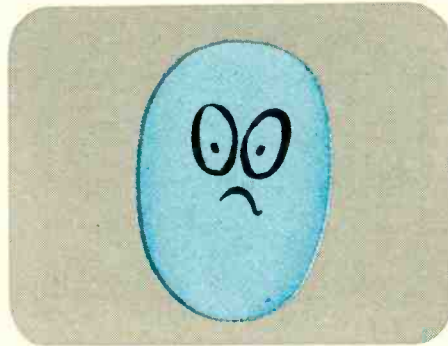

Focus on Jerrold Paralog Plus™ Coloraxial Antennas for true color

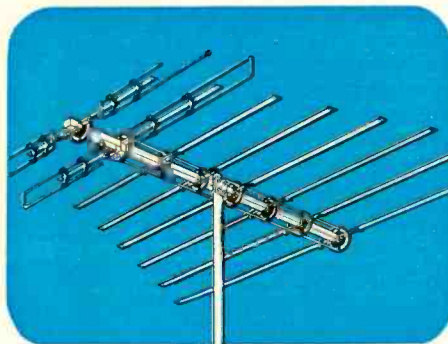

Jerrold Paralog Plus Antennas show a definite improvement in the sharpness, fidelity and color stability of the image on any TV set. Sharp directivity, uniform response and perfect matching see to that! And the rugged construction insures that the quality stays

high—not for months—but for years. It's the high-gain Coloraxial antenna for people who insist on VHF and FM reception—without compromise. And there are seven models to choose from.

The Paralog Plus is one of a complete spectrum of problem-

solving Jerrold TV reception aids—Pathfinder, VUfinder and Colorpeak antennas... Powermate pre-amplifiers, amplified-couplers and splitters... Coloraxial cable, wall outlets and wall plates. See your Jerrold distributor today. Catalog available on request.

JERROLD®

Focusing on one thing—
better reception

KWIKETTE Soldering Aids available these NEW ways...



Packet of 10 for 29c

Package of 100 for \$2.79

With all Sprague pre-packaged wire-lead service-type capacitors at no extra cost to you!

NOW... YOU CAN SAVE TIME, TROUBLE, AND \$\$\$ ON MORE SOLDERING JOBS

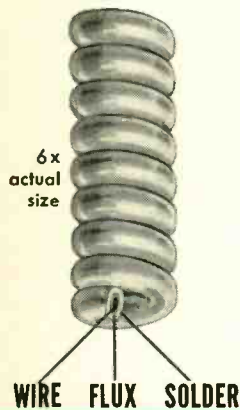

6x actual size

WIRE FLUX SOLDER

This is it: the revolutionary KWIKETTE that speeds component replacement... and practically lets you do "in-circuit" parts testing. This unique soldering aid is not just another wire spring connector. It features a Copperweld wire inner core, an intermediate layer of flux, and an outer jacket of solder... all you need is heat!

You can now buy KWIKETTES from your Sprague distributor in packages of 10 and 100. You'll also find them included with all Sprague pre-packaged wire-lead service-type capacitors... at no extra cost to you.

*Trademark

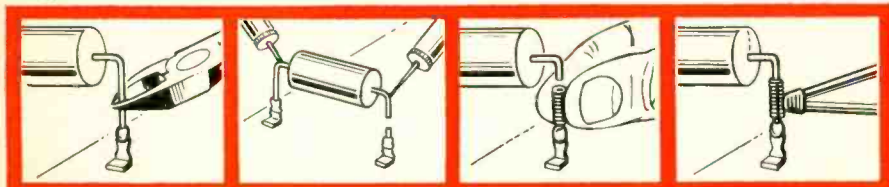

SNIP LEAD...

TEST...

SLIP ON KWIKETTE...

APPLY HEAT!

If you haven't tried KWIKETTES yet, do it now. They're the biggest boon to the service technician since the soldering gun!

DON'T FORGET TO ASK YOUR CUSTOMERS "WHAT ELSE NEEDS FIXING?"



In the Shop . . . With Jack

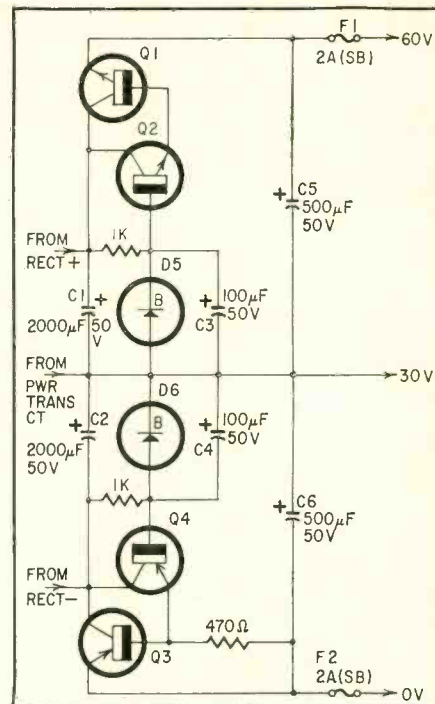

trying to start a thermal runaway. Since all the low-voltage current flows through it, it could have insufficient heat sinking or be defective (collector-emitter leakage). However, since Q3 is controlled by error amplifier Q4, it could be the "villain."

You might try this: As soon as the voltage starts to rise, cool Q3 with a spray coolant. If this doesn't help, cool Q4, or any of the others that might be affecting it. It might be helpful to hook ammeters into the two voltage-supply circuits, across the fuse holders, and see if any load change is taking place. Also check that 470-ohm bias resistor between Q3 and Q4, just on general principles. Transistor bias is very critical!

Short 6CB5 life

The 6CB5 horizontal-output tube in my RCA 21CS7815U color set does not last long enough. I'm getting only about 5 or 6 weeks out of each one! I note that RCA has discontinued this tube. Are there any other types that will last longer? None are listed in the tube-substitution handbook I have.—D. E., Cambridge, Md.

Too much current is being drawn through this tube. That is the only answer for the short life, if you have checked the horizontal output stage for shorts or leakage, and if the set works pretty well otherwise.

Run a complete horizontal output stage and HV adjustment procedure, as given in RCA's 1956 No. T4 service manual, or in Sams folder 353-11. Most

If the Electro-Voice Model 664 picks up sound here...



(E.V.) The holes in the top, sides and rear of the Electro-Voice Model 664 make it one of the finest dynamic cardioid microphones you can buy. These holes reduce sound pickup at the sides, and practically cancel sound arriving from the rear. Only an Electro-Voice Variable-D[®] microphone has them.

Behind the slots on each side is a tiny acoustic "window" that leads directly to the back of the 664 Acoustalloy[®] diaphragm. The route is short, small, and designed to let only highs get through. The path is so arranged that when highs from the back of the 664 arrive, they are cut in loudness by almost 20 db. Highs arriving from the front aren't affected. Why two "windows"? So that sound rejection is uniform and symmetrical regardless of microphone placement.

The hole on top is for the mid-range. It works the same, but with a longer path and added filters to affect only the mid-frequencies. And near the rear is another hole for the lows,

with an even longer path and more filtering that delays only the bass sounds, again providing almost 20 db of cancellation of sounds arriving from the rear. This "three-way" system of ports insures that the cancellation of sound from the back is just as uniform as the pickup of sound from the front—without any loss of sensitivity. The result is uniform cardioid effectiveness at every frequency for outstanding noise and feedback control.

Most other cardioid-type microphones have a single cancellation port for all frequencies. At best, this is a compromise, and indeed, many of these "single-hole" cardioids are actually omnidirectional at one frequency or another!

In addition to high sensitivity to shock and wind noises, single-port cardioid microphones also suffer from proximity effect. As you get ultra-close, bass response rises. There's nothing you can do about this varying bass response — except use a Variable-D

microphone with multi-port design* that eliminates this problem completely.

Because it works better, the E-V 664 Dynamic Cardioid is one of the most popular directional microphones on the market. It has both high and low impedance outputs available at the plug. Frequency range is peak-free from 40 to 15,000 Hz (cps). Output is -58 db. To learn more about Variable-D microphones, write for our free booklet, "The Directional Microphone Story." Then see and try the E-V 664 at your nearby Electro-Voice microphone headquarters. Just \$85.00 in satin chrome or non-reflecting gray, or \$90.00 in gold finish (list prices less normal trade discounts).

*Pat. No. 3,115,207

ELECTRO-VOICE, INC., Dept. 672E
613 Cecil Street, Buchanan, Michigan 49107



Circle 23 on reader's service card

The new Sony FM Stereo Tuner is highly sensitive. It pulls in the weakest stations sharply and clearly. For all its sensitivity, it is unusually insensitive. An ingenious new cadmium-sulfide CdS bandpass RF attenuator protects weak stations from being blanketed by strong signals. There's so much to recommend the ST-5000W. Double-tuning IF transformers, at all 8 stages of the IF section, reject spurious signals and noise. A 5-gang, high precision, silver-plated tuning capacitor contributes to excellent sensitivity. A

tuning meter pinpoints the center of any channel visually. Another meter helps adjust the antenna for maximum signal pick-up. A stereo switch automatically selects the correct mode—stereo or mono. An indicator light spots stereo programs. An adjustable muting switch suppresses interstation noise. Tune in the ST-5000W at your hi-fi dealer. Suggested list \$399.50. Sony Corp. of America, Dept. H., 47-47 Van Dam

SONY® St., Long Island City, New York 11101

Can a sensitive FM Stereo Tuner also be insensitive? Tune in and find out.



Circle 19 on reader's service card

NO COMPETITORS

Nobody else but **EMC** designs in so much value

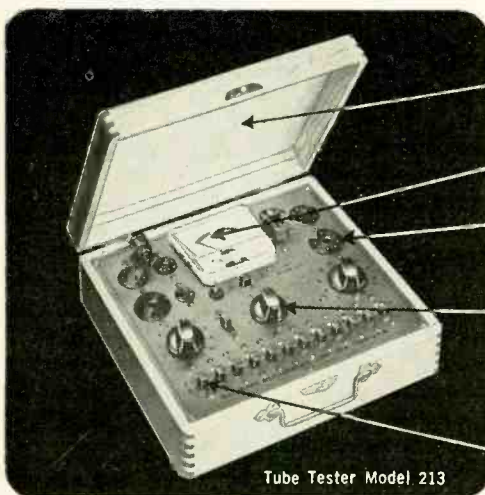

Compact, light-weight portability. Use it on the bench or in the field.

Full-view meter gives direct, clear-cut quality indications.

Three heavy-duty controls for quick set-up of all tests. Check a fistful of tubes in the time it often takes to test one.

12 slide switches for individual selection of tube pins provides versatility in testing, prevents obsolescence.

Full complement of sturdy sockets accepts compactron (12-pin), nuvistor, novar, 10-pin, 9-pin, octal, loctal, and miniature tubes.

Precise programming. Only one socket per tube-base configuration prevents accidental plug-in.

THE MODEL 213 saves you time, energy, money ■ Checks for shorts, leakage, intermittents, and quality ■ Tests all tube types including magic eye, regulator, and hi-fi tubes ■ Checks each section of multi-purpose tubes separately ■ Gives long, trouble-free life through heavy-duty components, including permanently etched panel ■ Keeps you up to date with FREE, periodic listings on new tubes as they come out ■ Your best dollar value in a tube tester. Available in high-impact bakelite case with strap: \$31.40 wired; \$20.40 in kit form. Wood carrying case (illustrated) slightly higher.

EMC

ELECTRONIC MEASUREMENTS CORPORATION
625 Broadway, New York 12, New York
Export: Pan-Mar Corp., 1270 B'way, N. Y. 1, N. Y.

EMC, 625 Broadway, New York 12, N. Y.
Rush me FREE catalog describing all EMC value-loaded test instruments and name of local distributor.

NAME _____
ADDRESS _____
CITY _____ ZONE _____ STATE _____

RE-6

In the Shop . . . With Jack

especially, measure cathode current! I think you'll find it far above normal; it should never be more than 200 mA. Adjust the horizontal efficiency control for a minimum or "dip" in this current, then check the regulator action.

Yes, the 6CB5 is a discontinued type; it has been replaced by the 6CB5-A, a much improved version.

Diode filtering

In your answer to a reader about avoiding crosstalk in a stereo amplifier, you recommended heavy filtering. There's another method, less expensive and very efficient. This is a diode in series with each branch of the supply! It is hooked up so that power can flow through it to the amplifier, but can't "back up"! The G-E Transistor Manual has several examples of this circuit.—J. H., Alhambra, Calif.

True for you! This is a very efficient method of getting isolation, especially in transistor circuits. You have to be sure that the diode used will withstand the voltage of the power supply, and also carry the maximum current required plus a good-sized safety factor, though. In high-powered amplifiers, the diode could turn out to be higher priced than a pretty big capacitor! You can get some monster capacitors now for very little cost. High-current diodes can run up to several dollars.

Capacitors are getting very small. When I started in the radio business, a 1,000- μ F capacitor would have been about the size of a small delivery van (and about the same price)! Now, they're smaller (cheaper, too).

Color CRT interchangeability

Can I replace a 23EGP22 color tube with a 25-inch type?—A. O., Staten Island, N. Y.

I can give you an honest answer, if not a very helpful one: I don't know! This question has come up repeatedly, but I can't get any definite information on it from manufacturers, and I haven't been able to make any actual experiments as yet. So, until I find out that this is *definitely* possible, I'd say wait!

Some conversions are feasible, such as replacing the metal 21AXP22 with the glass 21CYP22, which has better phosphors; but these two tubes are electrically identical. If your proposed 25-inch tube happens to be identical to the 23-inch, then it might be okay to convert. You could run into some unforeseen problems, mostly in scanning and convergence, and these could be rough indeed!

END

"I Purchased the Heathkit® GR-295 to Break Into Color, and I Found Your Assembly and Service Manual to be a Complete Color TV Education in Itself"*

*Mr. Philip A. Scandura, Phil's Radio & TV Clinic, Hackensack, N.Y.



Kit GR-295
\$479⁹⁵*
(295 sq. in. viewing area)



Kit GR-180
\$379⁹⁵**
(180 sq. in. viewing area)



What Better Way To Learn Color TV Than To Build One Yourself! Smart man, Mr. Scandura. He built a beautiful color TV set that's worth \$700.00 and got a free education in the process. You can

too, with either of these deluxe Heathkit high fidelity color TV's. Kit assembly is easy . . . you just mount the parts, wire the leads and even degauss, converge, and adjust the picture. Takes around 25 hours. UHF and VHF tuners, I.F. assembly and high voltage power supply are preassembled & aligned at the factory.

And each set includes a 178-page instruction manual that's lavishly illustrated with drawings, photographs, schematic diagrams, X-ray views of circuit boards and even 32 pages in full color. Only 59 pages are devoted to the simple step-by-step instructions. The rest is a comprehensive discussion on theory of operation, detailed descriptions of each circuit, trouble-shooting photos & charts, service information, adjustments and operation.

And The Performance? In his letter Mr. Scandura added: "Your engineers did an outstanding job in designing a set so easy to build, and which produces a picture quality superior to any commercially built set I have seen. What a thrill to find the set operating perfectly the first time I turned it on and adjusted the picture." Now compare these other exclusive Heathkit Color TV features!



Exclusive Self-Servicing Aids . . . built into both Heathkit color TV's so you can perform convergence and color purity adjustments anytime. Just flip

a switch on the built-in dot generator, and a dot pattern appears on the screen. The manual's simple-to-follow instructions and detailed color photos show you exactly what to look for, what to do and how to do it. Results? Beautifully clean and sharp color pictures day in and day out.

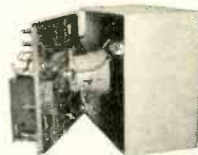

Vertical Swing-Out Chassis. All parts mount on a single one-piece chassis that's hinged to make it more accessible for easier construction, care and installation.

Your Choice Of Installation. Another Heathkit exclusive! Both color TV's are designed for mounting in a wall or your own custom cabinet. Or you can install either set in a choice of factory assembled & finished Heath contemporary walnut or Early American cabinets.

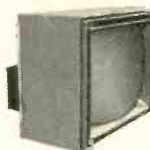

Exclusive Heath Magna-Shield! This unique metal shield surrounds the entire picture tube to help keep out stray external magnetic fields and improve color purity. In addition, *Automatic Degaussing*

demagnetizes and "cleans" the picture everytime you turn the set on from a cold start. Also permits you to move the set about freely without any manual degaussing. A mobile degaussing coil is included for initial set-up.

Convergence Control Board! . . . for fast, easy dynamic convergence and gray scale adjustments any time you decide color purity needs it. This board may be mounted up front, so there's no awkward reaching around the back of the set, or mirrors to set up.



Plus a Host Of "State-Of-The-Art" Features . . . like the hi-fi rectangular picture tube with "rare earth" phosphors for brighter, livelier colors and sharper definition . . . **Automatic Color Control** and **Gated Automatic Gain Control** to reduce color fading and insure steady, jitter-free pictures at all times . . . deluxe **VHF Turret Tuner** with "memory" fine tuning . . . **2-Speed Transistor UHF Tuner** . . . **Two Hi-Fi Sound Outputs** for play through your hi-fi system or connection to the special limited-field speaker . . . **Two VHF Antenna Inputs** — 300 ohm balanced and 75 ohm coax . . . **1-Year Warranty** on the picture tube, 90 days on all other parts . . . plus many more deluxe features. For full details, mail coupon for **FREE** Heathkit catalog.

*Kit GR-295, everything except cabinet, 131 lbs. \$479.95

GRA-295-1, walnut cabinet (shown above), 56 lbs. . . 19" D x 31" H x 34 1/2" W \$62.95
Deluxe contemporary walnut & Early American cabinets also available at \$94.50 and \$99.95

**Kit GR-180, everything except cabinet, 102 lbs. \$379.95

GRA-180-1, walnut cabinet (shown above), 41 lbs. . . 18 1/2" D x 28 1/2" W x 29" H \$49.95
Early American cabinet available at \$75.00

FREE!

World's Largest Electronic Kit Catalog!

Describes these and over 250 kits for stereo/hi-fi, color TV, amateur radio, shortwave, test, CB, marine, educational, home and hobby. Save up to 50% by doing the easy assembly yourself. Mail coupon or write Heath Company, Benton Harbor, Michigan 49022



HEATH COMPANY, Dept. 20-6
Benton Harbor, Michigan 49022

Enclosed is \$ _____, plus shipping.

Please send model (s) _____

Please send FREE 1967 Heathkit Catalog.

Name _____

Address _____

City _____

State _____

Zip _____

Prices & specifications subject to change without notice.

CL-286



Circle 25 on reader's service card

In today's electronics boom, the demand for men with technical education is far greater than the supply of graduate engineers. Thousands of real engineering jobs are being filled by men without engineering degrees—provided they are thoroughly trained in basic electronic theory and modern application. The pay is good, the future is bright...and the training can now be acquired at home—on your own time.

How to become a “Non-Degree Engineer”



Circle 26 on reader's service card

THE ELECTRONICS BOOM has created a new breed of professional man—the non-degree engineer. Depending on the branch of electronics he's in, he may "ride herd" over a flock of computers, run a powerful TV transmitter, supervise a service or maintenance department, or work side by side with distinguished scientists on a new discovery.

But you do need to know more than soldering connections, testing circuits and replacing components. You need to really know the fundamentals of electronics.

How can you pick up this necessary knowledge? Many of today's non-degree engineers learned their electronics at home. In fact, some authorities feel that a home study course is the *best way*. *Popular Electronics* said:

"By its very nature, home study develops your ability to analyze and extract information as well as to strengthen your sense of responsibility and initiative."

Cleveland Method Makes It Easy

If you do decide to advance your career through home study, it's best to pick a school that *specializes* in the home study method. Electronics is complicated enough without trying to learn it from texts and lessons that were designed for the classroom instead of the home.

Cleveland Institute of Electronics concentrates on home study exclusively. Over the last 30 years it has developed tech-

niques that make learning at home easy, even if you once had trouble studying. Your instructor gives the lessons and questions you send in his undivided personal attention—it's like being the only student in his "class." He not only grades your work, he analyzes it. And he mails back his corrections and comments the same day he gets your lessons, so you read his notations while everything is still fresh in your mind.

Students who have taken other courses often comment on how much more they learn from CIE. Says Mark E. Newland of Santa Maria, Calif.:

"Of 11 different correspondence courses I've taken, CIE's was the best prepared, most interesting, and easiest to understand. I passed my 1st Class FCC exam after completing my course, and have increased my earnings by \$120 a month."

Always Up-to-Date

Because of rapid developments in electronics, CIE courses are constantly being revised. This year's courses include up-to-the-minute lessons in Microminiaturization, Laser Theory and Application, Suppressed Carrier Modulation, Single Sideband Techniques, Logical Troubleshooting, Boolean Algebra, Pulse Theory, Timebase Generators...and many more.

CIE Assures You an FCC License

The Cleveland method of training is so successful that better than *9 out of 10 CIE*

men who take the FCC exam pass it—and on their first try. This is despite the fact that, among non-CIE men, 2 out of every 3 who take the exam fail! That's why CIE can promise in writing to refund your tuition in full if you complete one of its FCC courses and fail to pass the licensing exam.

This Book Can Help You

Thousands who are advancing their electronics career started by reading our famous book, "How To Succeed in Electronics." It tells of many non-degree engineering jobs and other electronics careers open to men with the proper training. And it tells which courses of study best prepare you for the work you want.

If you would like to cash in on the electronics boom, let us send you this 40-page book free.

Just fill out and mail the attached card. Or, if the card is missing, write to:

 **CIE Cleveland Institute of Electronics**
1776 E. 17th St. Dept. RE-36
Cleveland, Ohio 44114
Accredited Member National Home Study Council

ENROLL UNDER NEW G. I. BILL

All CIE courses are available under the new G.I. Bill. If you served on active duty since January 31, 1955, or are in service now, check box on reply card for G.I. Bill information.



Housewife Builds FM Stereo

SOMEBODY SAID, "ANYONE CAN BUILD A kit nowadays." I don't even remember who said it. I had stopped by the neighborhood firehouse to check a monitor, and one of the firemen had built a short-wave receiver in his spare time. He thought it was pretty great; but one of the others figured it was no big deal, and said so.

As I thought about it later, the idea occurred to me that a good test would be to let someone totally inexperienced try it. Why not a woman? Pick out some item she would really like to have and let her build it from a kit. Why not a stereo receiver? Heath Co. has a nice-looking table model, the GR-36. Maybe that would be the thing.

The woman who undertook this

"The manual said to make sure you have all the parts. I didn't know one thing from another, but I found the foldout pictures in the instruction book and I read the Kit Builder's Guide that was in the box. Checking off the parts is a big help in getting familiar with them. I finally got them all together. The little Guide shows a neat way to arrange things so they'll be orderly and handy."

How can you manage to work on a kit and still keep up the routine of housework, school lunches, and so forth?

"The first thing to do is find a place where you can set up all the parts, etc., so they won't be disturbed. You'll want to be near an electric outlet for the soldering iron. I used a card table and it worked fine. Once you get started and

No sweat, she said. "The numbers on the parts list, the ones that key the parts descriptions to numbered pictures, make it impossible to pick the wrong part. In many instances, the number appears on the part itself."

Resistor color codes?

"The Kit Builder's Guide tells how to read them. But who needs to? When the manual calls for a resistor, the color code is written out (orange, orange, yellow) right after the value (330K). All I had to learn was which end of the resistor to read from."

Any advice for the inexperienced?

"Yes. Read *all* the directions for each step *before* you start doing it. Each time I didn't, I wasted time looking for the wrong part or having to go

**Busy mother of
two builds her
first electronic kit**

**By JEFF TRACY
and LEE SPENCER**



"I've never understood miracles such as radio and television." Young housewife unpacks her very first electronic kit.



A heavy gun was unwieldy. Part of work was done with 40-watt pencil iron. Parts are identified with help of Kit Guide.

project is a housewife and sometime career woman, attractive mother of two, and—as she puts it—"someone who has never understood such miracles as radio, television, etc." She had never touched a soldering iron. She wasn't at all sure she could build anything as complicated as a radio, no matter how explicit the directions, but she was willing to try.

The point of the experiment would be to discover whether she could build the receiver with no help. If she couldn't, we wanted to know exactly what aid she would need. Specific instruction in certain skills might be necessary. Also, we wondered how much more than the normal building time it would take for a totally inexperienced builder.

One evening late last winter, she set to work. Unpacking the first box took a lot of time. She had no idea what the parts were (she'd seen tubes before, but the GR-36 is all-transistor). Let her tell you herself.

find how interesting and satisfying it is, you manage to make the time for it.

"When you finally start the assembly, you should work only as long as you enjoy it. Quit when you get tired, because you make too many mistakes otherwise."

The first snag was soldering. Despite the Guide and the kit manual, our young housewife didn't feel confident about soldering. A 5-minute instruction-and-practice session, plus checking the first few connections she made on the board, sufficed. She used a lightweight soldering gun for most of the work, but did some with a 40-watt pencil iron. One heavy gun she tried was entirely too unwieldy.

At first she had a little trouble clipping the wires; she'd never held a pair of diagonal cutters. Even after she mastered them, she held them differently than I do, but she got the wires clipped.

I expected her to have more trouble identifying parts than she actually had.

back and do something over. It took me 20 hours to build the radio, and I know it can be done in much less.

"Also, check off each step as soon as it is done. Once I waited till I'd done a whole string of them and then just went down the side putting check marks. Later, I found I'd left out one step. More wasted time."

Could you have done the job alone—that is, with no help at all?

"No, I don't think so. It's my opinion that you need someone you can ask questions. At least, you do if you know absolutely nothing about radio or electronics, like me.

"The manual gives thorough and easily understood instructions. Sometimes I had doubts about what they were saying. When I had no one to ask, I just kept rereading the directions until they made sense. When they did, finally, I wondered how I ever could have misunderstood."

This directions business is the key

to a lot of problems kit-builders have, sometimes experienced ones worse than beginners. In most cases of kits returned for factory repairs, directions have not been followed.

Our housewife, for example, rushed in and cut two leads too short on the tiny grain-of-wheat stereo indicator lamp. "I read the directions and I used the ruler, but there they are, too short," she explained when I stopped to answer a plea for help. "Now the lamp won't reach through its little mounting grommet on the panel."

No replacement was handy for this odd little incandescent, so I did a tricky solder job with tiny wires and made it reach.

After the radio was done, I asked what part had been the most difficult. I had figured probably the dial cord would be a hangup.

"Things were going fine until I got

I guess so. . . ."

Well, you know how women are . . . I was still wondering about that dial cord. I knew the mechanical part of stringing that would really be tough for a woman. But she wasn't ready to talk about that (I figured I knew why!).

Her eyes were lighting up now. "When I got to page 22," she went on, "and was connecting the wires from control H to the amplifier circuit board, I was feeling a bit crowded. There wasn't much room to work. I began to worry again. I was afraid things were going to get so congested that I'd make a mistake on which wire went to which hole.

"My fears were for nothing. I found when I'd finished that page that I was through with that kind of work. Hadn't even broken a fingernail.

"Then I felt a little disappointed. It was kinda fun being able to do such careful work without burning up every-

for the big moment: plugging it in for the first time. Our housewife tells it better than I do.

"There's nothing to tell. It just did not work. I'd have been surprised if it had, but I was plenty disappointed that it didn't. My first thought was: What a lot of work, for nothing."

Really, it wasn't as bad as all that. We did the first thing recommended for any circuit-board kit that doesn't function. We touched a hot soldering iron to every joint on the board. The trouble was merely a cold-solder job on one resistor.

When that radio gave forth music this little housewife tried her best to look nonchalant and unconcerned. She couldn't hide it, though; she was proud as she could be.

I was going to give it a good alignment job, so it would perform its best. But, except for a touchup of the multi-



"At one point, there wasn't much room to work. But it was kinda fun doing careful work. Didn't even break a fingernail."

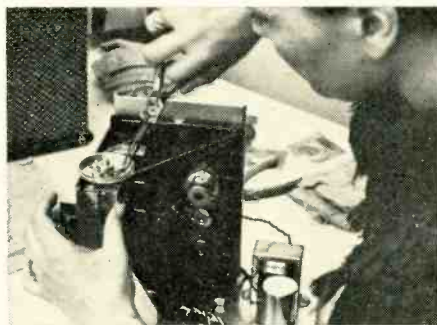

"Must have taken all of 15 minutes to get the dial cord done." Hmm . . . the mechanical ability of this woman!



"I built it. I'll put it in the cabinet." She even connected the stereo speakers in proper phase. Radio now is her companion.

to page 13. I had to trim the leads on the power transformer and strip the ends. I was shown how to do it on one and then I tried the next one. It took me forever.

"I was really worn out by the time all five leads had been stripped. I was also discouraged, because I knew there would be more leads to strip. The thought of the struggle with those five was enough to make me want to quit the whole project right there.

"However, I was enjoying myself except for the stripping so I figured I'd go on anyway till I got to the next stripping step.

"Sure enough, on the very next page there were more wires to be stripped. What a relief it was to discover that these were very easy! They were small and slick. All you do is run a razor blade lightly around the insulation and it slips right off. I was told the other wires were stranded and the insulation was cloth; that's why I had so much trouble.

thing around it with the soldering iron."

Come on, come on, the dial cord. "Oh that. Well, they sure mean what they say in the directions."

I tried to conceal a knowing look of masculine superiority.

"It must have taken me 15 minutes all together—getting that little spring hooked, and then doing it over twice. Yes, it took me a while."

Fifteen minutes! That's less time than I figured it would've taken me, so I brushed on to ask why she had to string it over.

"Well . . . the directions said to wrap it 3½ turns around the knob shaft. To make it reach all the way to the end, I could only get 2½ turns. When I tried to turn it, though, the thing kept slipping. I finally decided that 3½ turns means 3½ turns. By stretching the string and the spring, I got it wrapped 3½. I never should have doubted the directions."

D-day finally came. The last step had been checked off and I was there

plex adjustments, there was nothing that needed aligning. Tracking was good, selectivity fine, reception great, and stereo excellent. She insisted on putting it in the cabinet herself.

I checked back when I was putting the finishing touches on this article. She's still happy with the set. She keeps it in the kitchen and gets a lot of enjoyment from it. I asked her if she'd learned anything about electronics from building her stereo-FM radio.

"Well, I know there are a lot of little parts, and I can identify them by name. But how that conglomeration can actually produce music is more of a mystery to me now than it ever was."

I asked if she thought she'd enjoy building more kits.

"I haven't thought too much about it," she said. "This one was fun, but it took a lot of my time."

She was thinking. Then, "You know, we don't have a color TV. . . ."

END

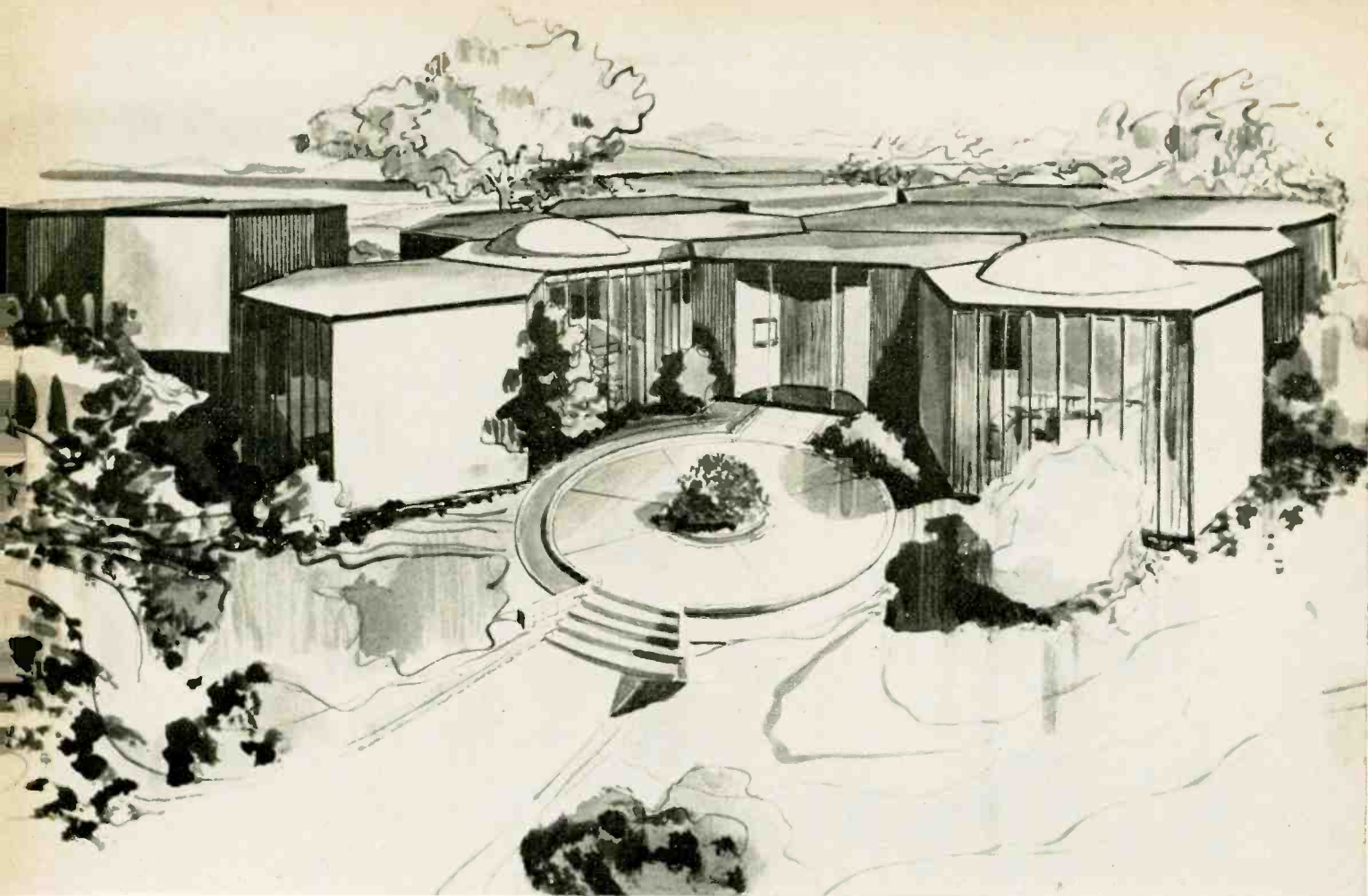

HOUSE OF TOMORROW

By BRUCE WARD

THE HOME OF THE FUTURE MAY WELL BE POWERED by a fuel cell, efficiently managed by a computer and most important to you—provide electronics engineers and technicians with a large slice of a new multibillion dollar market.

The Philco-Ford home of tomorrow shown and described here is part of a research project headed by George C. Crowley* which actually crystallizes a great number of random ideas about the future of home environment and (significant for the electronic community) presents a total electronic concept.

We would like to have you join us on a limited room-by-room tour of this exciting home. Then we'd like to make a suggestion on how to reduce the lead time needed to move this project from the planning stage into the construction and maintenance stage—which is where the electronics industry should reap its largest benefits.

The living room, with its wallsized television screen, is the focal point of this house.

*Vice-President Engineering and Research—
Consumer Products.

The TV screen is three-dimensional or holographic, enabling you to look around corners almost as though you were inside the scene being projected. We expect that electroluminescence is going to be the medium for displays of this type.

Notice that the wall section is actually made of variable-opacity windows. These enable you to shut out the outdoors completely, or you can let filter through whatever amount of natural light you want. You can also adjust the color of the glass to match your furniture, your walls or your mood—whatever pleases you at the moment.

In the lower portion of the living room is a console which controls all entertainment and lighting functions throughout the home. You can have light of any intensity or color.

The utility core is bound to be of tremendous interest to you since it houses the heart of the entire household system. At left is water heating and storage equipment. Next is the fuel cell, which produces all the electricity needed by the home. The cell is fueled by liquified gas from a storage tank buried under the house or a pipeline from a central community source. The fuel cell also provides absolutely pure water in more than adequate supply. In addition, heat from the cell is used to warm the

home. All waste products from the house are incinerated by gas.

In the center of the utility area there are two devices. At the top is the service monitor, at the bottom, the environmental control. Every few seconds, these monitors check the hundreds of electronic circuits required by this house. An electronic switchover inserts a backup circuit when trouble develops. They also are programed to alert either a local serviceman or your servicing agency automatically when maintenance is required or a breakdown occurs.

The environmental control system analyzes the air in the home for impurities, odor, moisture content and temperature. The air is then filtered, warmed or cooled, moisture added or removed, and a pleasant odor (dial your choice) injected.

At the right is the household computer, and it is used in an amazing variety of ways. The reels you see hold computer-memory tapes. They contain everything from the latest entry in your checking account to every page from every volume of your favorite encyclopedia. The computer is the heart of this house system and provides the cohesive element that maintains order in the daily functions of all its electronic devices.

The utility core takes up only half of a hexagonal room. The outer half is devoted to a hobby area which we will take you through after we have looked at what is generally considered the woman's domain.

At the far left of the kitchen is a food processor. It is both a freezer and a microwave oven, and is computer-directed. Food from the freezer goes automatically to the oven at a preset time in specified quantities to be ready for serving at the dinner hour.

The next unit, and one which seems to catch the fancy of most people, is a dishmaker. We foresee this development making its way into kitchens before very long. A simple machine using powdered plastic makes disposable dishware cheaply and quickly, eliminating both storage and washing of dishes.

In another part of the kitchen is mother's electronic console, and in the window area is her herb garden. The four panels at the bottom of the video screen are used for shopping. The housewife is placed in video contact with the store of her choice via microwave transmission. If she is shopping for food, the amount is determined by the computer. (If she wishes, she may even shop automatically: The computer's record of house occupants' weight determines the quantity of food ordered and the amount processed at mealtime.)

The video shopper scans—through a camera in the store—the shelves and counters the lady of the house selects. She orders by pushbutton. The store computer then totals the bill and sends it electronically to both her home computer and the bank's computer. The bank computer debits her account and credits the amount to the store. Finally, the bank computer notifies the home computer of the new balance.

At left, above the shopping device, is a household visual monitor. TV cameras continuously view such critical areas as the nursery, the swim-

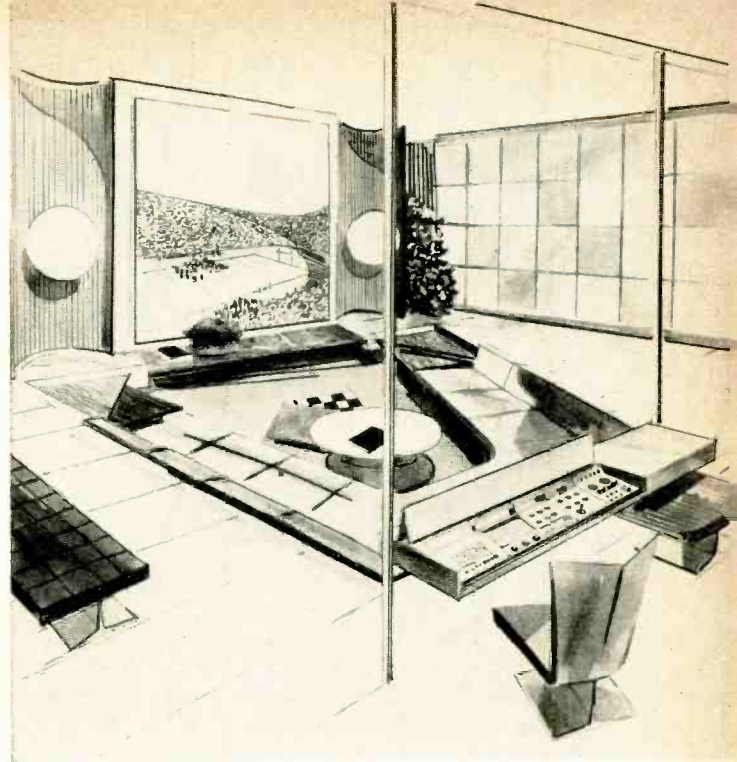

Living room, dominated by three dimensional television screen. Shown at right is control console.

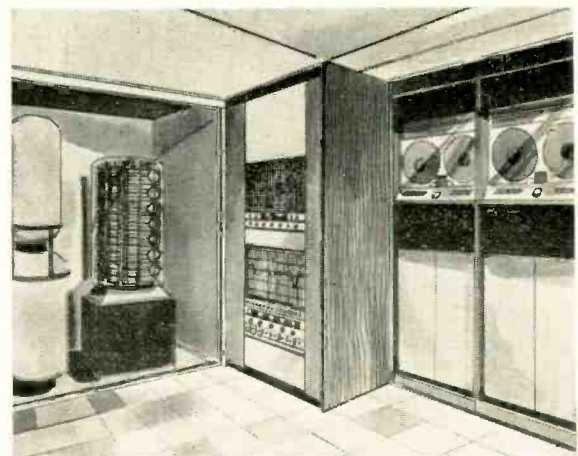

Utility core with water system, fuel cell, service monitor, environmental controls and computer.

Kitchen shows food processor, which is both a freezer and oven; dishmaker is at top center.

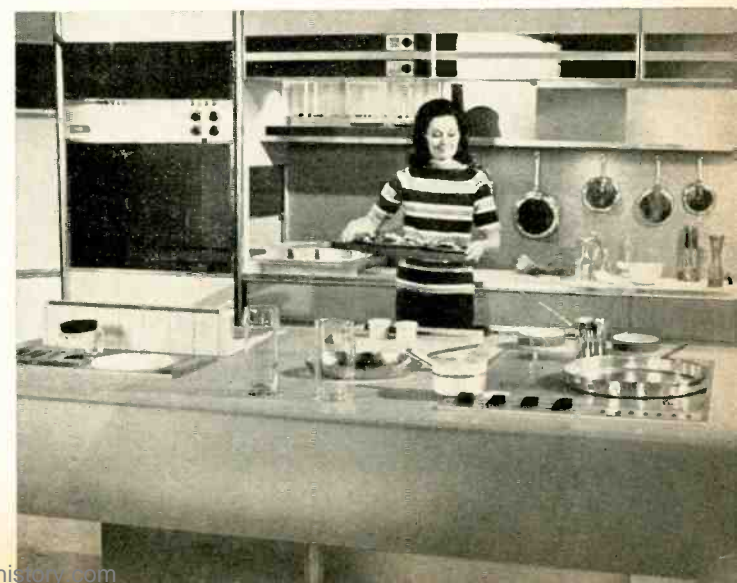

HOUSE OF TOMORROW

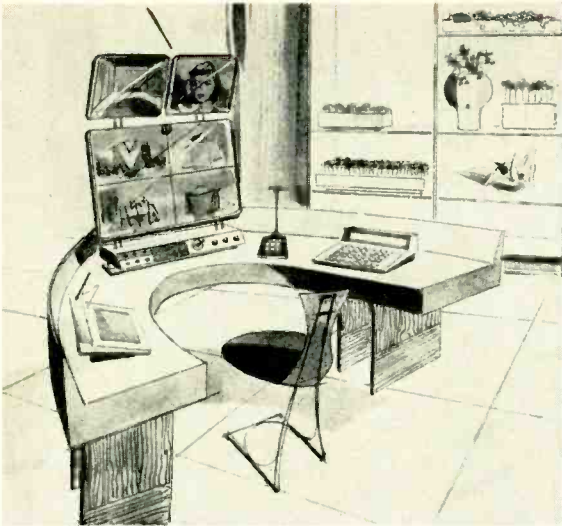

Kitchen also houses mother's electronic console. At left, above shopping device is household viewer.

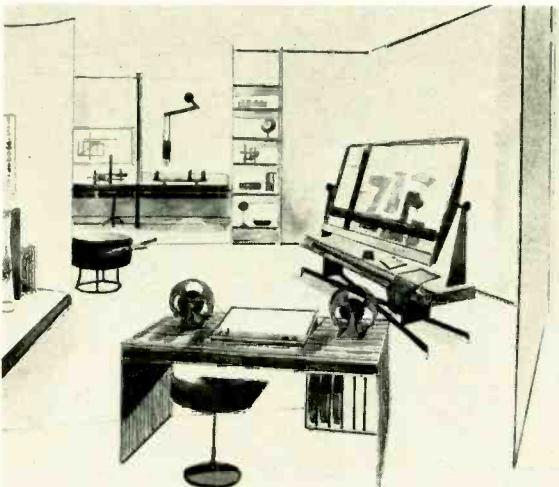

Hobby area shows laser at rear, electronic pattern maker at right and video tape splicer below.

Bedroom features adjustable bed, automatic heat controls and unique subliminal education system.

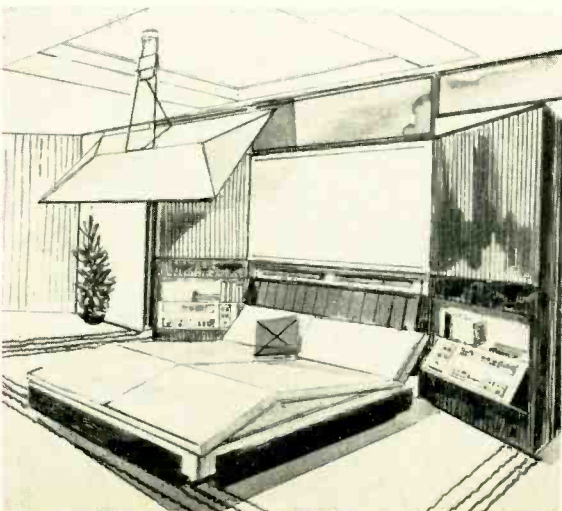

ming pool and the play yard. A picture is displayed on the monitor whenever an intruder alarm detects a moving object approaching the house. The screen at the top right of the shopping console is a video telephone.

The balance of this console is a message center which won't let the lady of the house forget engagements, because they are stored in the computer and presented to her daily.

The hobby area houses relatively few, but highly complex, instruments. All can be used from the design stage to the finished product in any medium you care to work in . . . clay, glass, wood, metal or plastic. The workbench at the right reproduces electronically any patterns you either select or create for your work. The finished pattern is stored in the computer for instant recall, and you can, of course, use pieces of old designs, models, patterns or maps previously stored in your computer to speed along a new project.

At the rear of the room is the metal- or wood-working area, which houses a laser for cutting, drilling and finishing nearly all kinds of materials.

In the bedroom of the future you sleep in unencumbered comfort. The bed is adjustable, so you don't have to toss and turn to find the just-right spot for sleeping. You have no blankets; the heat . . . adjusted automatically to compensate for changes in room temperature . . . comes from radiant panels in the ceiling.

The overhead lenticular TV screen allows two people to view separate programs at the same time. The console beside the bed controls TV, music, sleep-inducing sounds and whatever subliminal educational material you want fed into your subconscious while you're sleeping.

Our tour ends and yet you have seen only about one-third of this exciting home. This is for two reasons. The first is our space limitations. The second is more important: What you have seen, plus the remaining two-thirds of the Philco-Ford home of tomorrow should really be seen by you and your family in a full-color film that is forthcoming. Only then can you really appreciate the full impact of this electronic concept.

The 16-mm sound motion picture will be shown later this year in a number of communities throughout the US, both in commercial theaters and by Philco-Ford dealers. Subsequently, the film will be supplied without charge for school and group showings through the *Ford Film Library* at one of the following addresses:

East: 16 East 52nd Street, New York, N.Y. 10022

Midwest: The American Road, Dearborn, Mich. 48121

West: 4316 Telegraph, Oakland, Calif. 94609

We have seen this entire home, and can assure you that the film is worth seeing. With the support of American housewives and teenagers, we feel the lead time needed to move this electronic project from the planning stage to the engineering and testing stages and finally on to the corner lot can be drastically reduced.

END

Midyear Report on Electronics

An analysis of where we stand and where we're going

By LARRY ALLEN

HERE WE ARE, PRACTICALLY HALFWAY through 1967 already. Sort of makes you wonder where time goes. Less than 6 months ago, many were predicting a cooling or slowing of the electronics boom. Let's look in retrospect at how the electronics industry is progressing. I'll even take a peek through my crystal ball at how the rest of the year will go.

First, I'd like to bring out a few quick points. What is happening in electronics is tied up with the economy of the nation as a whole, and we'll delve into that. Briefly, the predicted cooling seems very light. Money has eased up slightly and indicators are pointed upward again. At midyear the effects have been less depressing than expected.

Though prices are up throughout the economy, home entertainment actually costs less. Based on the Wholesale Price Index, with a reference of 100 on 1957-59 prices, commodity prices are up to 106.3. Television, radio, and phonographs on the same index are at 83.9. Home entertainment is a better bargain than many staples.

A penchant for quality permeates the entire industry this year. The shortage of technicians to service their products has induced manufacturers to take closer looks at serviceability and reliability. Consumers are more conscious of service needs. With technicians hard to find, owners (fearing costly repair bills the press and TV have led them to expect) want sets that are trouble-free.

Manufacturers are also making units more compact and economical. With color TV sales slackening, retailers expect more spending on other home-entertainment equipment. So, manufacturers are gearing up to fill distribution channels with better and less expensive equipment.

Electronic manufacturers want their share of the consumer dollar, and they are getting it. With the nation's economy growing at only a 3% rate, the consumer-electronics industry is booming along with slightly above 12% growth and hoping for better.

The service-technician shortage is worse than at the start of the year. Good help is hard to find in engineering and

manufacturing, too. The trouble seems to include several factors: (1) The increase in consumer purchases has far outstripped the number of skilled electronic graduates. (2) In the ranks of the so-called experienced, many have not kept up with advancing technology and now border on incompetency. (3) Wages don't approach those of skilled trades, much less of professions. (4) Scandals, giving the service industry a bad name, have deterred interested students. (5) Many training programs are inadequate. (6) Not enough promotion is done to attract new men to the field.

Industry leaders are attacking all these drawbacks. About 160,000 technicians are available to take care of home-entertainment equipment. Some say only half of these are competent; I'd guess nearer 70%. By the end of this year, the need for *competents* will stand near 175,000. The quota won't be filled.

Prices of home-entertainment gear are lower by comparison with other commodities. Quality is up. Size is getting smaller. The technician shortage is now the worst drawback in electronics.

By 1970, we'll need 75,000 more. We must train that 75,000 *plus* enough to replace those who haven't kept up and who drop out. If equipment weren't reliable, we'd need even more by 1970 than the 250,000 I estimate.

The problem of service will continue to be a damper on sales, but the boom will persist despite this drawback. By the end of this year, the industry will have taken a long and careful look at the reputation earned (fairly or unfairly) by those front-line spokesmen—the service technicians. Everyone concerned should by that time be taking definite action to restore customer confidence and to generate technicians who can inspire such confidence.

Color TV

The sweetheart of electronics

growth for 3 years, color TV sales are slacking. There were 2.7 million color sets sold in 1965 and 4.7 million in 1966—less than a 75% increase. So far this year, sales are moving along at a rate that promises less than a 50% increase in sales. This pegs the year's total sales figure at under 7 million. For the first time, though, color sales will exceed b-w sales (about 6 million b-w sets).

At midyear, nearly 17% of the country's TV receivers are color. By the end of 1967, that figure will be above 20%; there will be almost 90 million sets and 17 million will be color.

Pretty though the picture is for color-set sales, the dollar figures look even nicer. The dollar volume of TV sales will be 80% color, although only slightly above 50% of units sold will be color. The reason is, of course, the higher price of color receivers.

The 25-inch (295-sq in) is popular, and it sells above \$500. The still-popular 19-inch may get stiff competition this year, not from the 25-inch set but from 16-inch 90° Japanese sets. This may portend a rush to portable color TV's. With new ones now \$200 or less, look for a jump in color-portable sales.

Small sizes suggest solid-state. It is mainly the Japanese who are optimistic; they plan solid-state color by year's end or early 1968. One US company says 1970. That's too conservative. The truth is, we *could* have it right now. As rapidly as semiconductor prices are dropping, we should have our own solid-state color sets on the market within the next 12 months.

Color TV has invaded the rest of the world, too. Canada began colorcasting last September and is now in full swing. Already, nearly 150,000 color sets are in use. By the end of the year, Canada will have over 200,000 homes with color TV.

Mexico is airing her first colorcasts. It's too early to say how quickly or widely color will catch on south of the border.

Europe is still debating PAL or SECAM. (See "Color Television Systems: Which Way Will Europe Go?" in July

Midyear Report

1966 R-E.—*Editor*). Apparently, there will be no single standard for the Continent. The dream of Eurocolor is practically extinct. By late this year, however, Europe will have 250,000 color receivers. The rate of growth after that should rise spectacularly.

Cartridge tape

The new glamor field is cartridge tape. Its growth rate may never reach that of color TV's heyday but it is climbing. Industry reporting is incomplete, so dependable statistics are not possible. We can only estimate progress.

Any way you turn in the field of cartridge tape, you run into disagreement. First arguments were about speed. Next, it was what kind of cartridge. Then, controversy raged between 4-track and 8-track. Now there's still another: between loop cartridges and dual-reel cassettes. And there are endless disagreements on how many of what will be sold to who for how much.

The 4-track vs 8-track argument probably was the hottest. The contest is ended for all practical purposes. The 8-track system is the one, but there will be plenty of 4-track equipment around. The first systems were 4-track; early aficionados have libraries of 4-track tapes that won't play on 8-track gear.

One reason for eventual dominance of 8-track cartridges is the support of the auto industry. About 80% of the 1968 cars that come equipped with cartridge-tape machines will have 8-track units. Another reason is the support of major record companies. RCA Victor, Capitol, and Columbia were releasing only 8-track prerecorded tapes. Now, Capitol and Columbia are both producing 4-track tapes to supplement their 8-track lines.

Cartridge-tape machines are replacing color TV as the sales leader. With an estimated 1.5 million units being sold this year, anyone not selling machines or tapes will be missing a nice profit.

A couple of machines seem to be compatible—useful for either 4-track or 8. The 8-track advocates count these 4-8 units as an interim step for owners of 4-track libraries who want to switch to 8-track eventually.

Now there's a new choice to be made. Late last year, North American Philips (Norelco) introduced a dual-reel cartridge they call a cassette. The system works, but the record companies

mentioned earlier are so far staying with loop-type cartridges. Only Mercury of the major record companies is releasing prerecorded cassettes. As of mid-year, the cassette hasn't quite caught on.

The cassette is 4-track, and plays at 1 7/8 ips instead of the 3 3/4 ips of loop-type cartridges. Detractors insist fidelity isn't satisfactory.

Prices of cartridge-tape players range from inexpensive 4-track units at about \$30 to original-equipment 8-track auto systems for around \$150. Home units in fancy cabinets can run higher. The tapes generally sell at \$4.95 for 4-track and \$6.95 for 8-track.

As I mentioned earlier, statistics are spotty up to now. However, here's the best information I have:

First, the machines. As original equipment, about 425,000 1967- and 1968-model cars will carry 8-track units, and possibly another 50,000 will be sold with 4-track. Estimates of add-on units in the after market range from 500,000 to 750,000. Home-type cartridge units should add another 500,000 to the overall total. You see, we're talking about 1.5 million cartridge-tape machines for 1967.

Guesses of units already in operation are from 750,000 to 4.5 million, with little hope for verification.

Statistics on tapes are a little more dependable. Total sales of prerecorded tapes, including both reel-to-reel and cartridges, were nearly \$50 million during 1966. Projections for this year suggest a total of \$100 million. The cartridge slice of that will be about \$60 million—a respectable sum.

More home entertainment

Television is the principal item of home entertainment, and has been for more than 15 years. At mid-1967, better than 95% of all US homes have at least one set and 28% have two or more. Sales of black-and-white TV sets have stabilized. The number of sets sold so far this year indicates that b-w TV sales will be almost as good as last year—about 6 million sets for 1967.

The dollar volume of b-w TV will be down, mostly because of a trend to small screens. So far, 40% of all b-w TV's sold are 16 inches or under. Imported small-screen receivers contribute to the lower dollar total: Japan alone will ship more than 2 million into this country.

Innovations are few in b-w TV this year; minor circuit improvement is about all. RCA predicts a pocket-size b-w TV in 3 years. With integrated circuits (IC's) and large-scale integration (lsi), 3 years seems like procrastination. Someone is sure to have a pocket-size set ready sooner (it might be Japanese).

The grandfather of home entertainment is radio. There are more than 250 million radios in the homes and automobiles of the United States. Sales move along at a brisk pace, with FM the boomer. Of the 44 million radios sold in 1966, over 25% were FM. At mid-year, the expectation for 1967 is a total of nearly 40 million units. About 15 million will include FM.

The inroads of imports have been deepest into the radio market. Of the 40 million sets to be sold this year, 24 million (60%) will come from abroad. About half are sold under US brands.

Next biggest home-entertainment market is that of high-fidelity and phonographs. This market right now is relatively stable. Last year, just over 16 million phonographs (88% portables) were sold. Sales for 1967 will stay about the same—another 16 million.

7 million color sets, 6 million black-and-white sets, 44 million radios, 16 million phonographs. Someone has to sell them—and service them. Not much slack time for service techs.

Large gains in tape sales are being boosted by cartridges and a strong swing from disc recordings to prerecorded tapes.

Integrated circuits are making an impression on the home hi-fi field. Explanations vary: reliability, space saving, economy, public glamor, and so on. Whatever the reason, they are popular in systems this year.

The hi-fi industry has predicted a 10% to 15% increase in sales for 1967; at midyear they are on the low side—about 12% growth rate.

A sleeper has been electronically amplified music. Practically every instrument imaginable can now be amplified, but still leading the sales parade by far is the guitar. The electronic musical instrument field this year will gross about \$400 million. Half of that will be for guitars and amplifiers, and a significant percentage will be for electronic organs.

Electronic communications

A hot sales item for 4 years, Citizens band is losing steam. The Federal Communications Commission (FCC) finds that only 10% of CB licenses renew. That doesn't mean CB is dead—far from it. There are 850,000 class-D licenses, representing about 3.8 million transceivers already in operation. The market projection for 1967 is \$50 million worth of CB transceivers and

another \$15 million for antennas and accessories.

The hobbyist is the fastest disappearing CB buyer. The Citizens Radio Service was never intended for "hamming," and tight regulation is forcing would-be hobbyists off CB channels. They either move to the Amateur Radio Service or quit. Almost half of all class-D licensees want CB radio for business. This is almost hopeless in metropolitan areas because of channel congestion.

CB sets are sold by discount stores and catalog houses as well as by about 3,000 CB dealers around the country. Few radio-TV service shops either sell, use, or service CB equipment (they missed a profitable bet, here). The big thing in CB right now is the Part 15 unlicensed 100-mW transceivers so popular with youngsters.

Two-way-radio shops, those engaged in selling and servicing commercial communications gear, generally have scorned CB. The converse, however, is not true. Nearly half the businesses that entered the communications field through CB have also branched into commercial two-way—selling and servicing both Business Radio Service equipment and transmitter-receivers for the other land-mobile services. There are more than 2 million such sets in use now.

Some service shops have gone further, into marine and aircraft electronics servicing. With the increase in general-aviation aircraft, plus a proliferation of communication and navigation devices, there is a more acute shortage of technicians in the aircraft field than in home entertainment.

Microwave, that offspring of commercial communications, is finding increasing uses. It is now used in anti-missile work, communications relays, space data communications, all-weather landings for aircraft, radar systems, fast-scan radar for supersonic planes, television and CATV relay, and so on. New solid-state microwave oscillators are probably the most important recent development because they will cut cost, trim space and weight requirements, and improve reliability and equipment life. Microwave is becoming a giant of an industry in its own right, instead of being merely a branch of communications.

Broadcasting is the branch of communications most significant to the consumer. AM, FM, stereo FM, and TV contribute heavily to home entertainment.

Many leaders predicted the demise of radio when television hit its stride in the early 1950's. Not so. There

are right now more than 4,100 AM broadcast stations, although their numbers are not growing much. FM stations are on the increase; there are over 1,800 of them, nearly 600 broadcasting stereo. More than 300 new FM stations are under construction. The climb in FM receiver sales is a tribute to the popularity of FM programming. Some FM stations are cashing in by selling inexpensive single-channel receivers tuned only to their own frequency.

Broadcast-equipment makers confirm that more transmitters are being bought and installed for FM than for AM. They also tell of a surge in automatic programming and logging equipment for both radio and TV stations.

The biggest move at TV stations is still to color. By the end of 1967, about 180 stations will be equipped to originate live color, 475 to handle filmed color, and practically all to retransmit color from other stations or the networks.

Citizens band is slowing down, but commercial two-way radio is making up for it. Broadcasting is at all-time high, with FM showing most progress. CATV is still strong—1,800 or more by year's end.

Uhf TV still plugs along, not getting nearly the attention the FCC would like. Of 670 television stations on the air, 140 are uhf. While only 56 vhf stations are under construction, 243 uhf's plan to take to the air soon. Educational TV is filing for uhf stations in some areas, and other special-purpose programming experiments are taking advantage of plentiful uhf TV spectrum.

Another TV project is direct-to-home telecasts from satellites (see photos). Some predict this is 5 years away; others say only 2 years. The problem right now is making satellite transmitting power sufficient to deliver a dependable signal to home antennas.

New technology is the likely answer. The problem won't be solved this

year, although important steps will soon be announced.

That former (?) foe of television broadcasters—CATV (community antenna television)—has become a major industry segment. There are 1,750 systems in operation, serving an estimated 8-million-plus audience. That's a husky chunk of the entire television audience.

The FCC took authority over CATV last year. Regulation has slowed CATV expansion slightly, as has the mushrooming cost of putting a system "on the wire." Telephone companies have become hesitant about leasing pole space, and community leaders demand a larger slice of the pie in return for a franchise. But CATV is still expanding, and will number over 1,800 systems by the end of 1967.

Miscellaneous electronics

This is a catch-all category. There aren't a lot of statistics, but at least you'll find out what's going on.

Automotive electronics is popular, because of interest in auto safety. Electronic research is going ahead furiously on automatic steering, collision warning, traffic control, laser-actuated braking, and dozens of other projects barely in the developmental stage. Before this year is ended, look for at least two significant electronic contributions to automobile safety.

Electronic ignition systems are still popular with experimenters and kit-builders but not with auto buffs. The newer systems are much improved over early versions, but the disenchantment that followed fantastic claims is still dampening sales. They may pick up as more new cars use electronic ignition.

Electronically propelled cars will eliminate ignition systems; fuel cells lead the way. Don't expect much this year, but another year or two may alter the face of surface transportation.

In *medicine*, the most newsworthy advances lately have been heart pacemakers; electronic diagnostic consoles that permit faster and better medical care; and servo devices that amplify nerve-end impulses to move artificial



CBS news program (left) and overseas news relay from Vietnam via Early Bird satellite. Quality of transmission is even better on programs from the newer Intelsat-2 series.

Midyear Report

limbs much as a real limb moves.

Emphasis on *air pollution* in larger cities creates a market for instrumentation to measure and monitor air content, as well as precipitators to collect dust and purify air. Smoke abatement dates from the days when photocells in chimneys were the most sophisticated pollution monitors. Today, electronic devices can analyze a cubic-inch sample of air for chemical, gaseous and solid content.

Small parts

An industry report wouldn't be complete without some statistics about replacement parts. You can't ignore a \$5.5 billion business. Its growth has been steady, but not spectacular—a mere 7.5% per year. By the end of 1967, the parts industry should be hovering around \$6 billion in sales.

The small part with most glamor is the integrated circuit. Sales of IC's are rising faster than those of any other component. In 1965, IC sales were above \$150 million. By the end of 1966, sales had nearly doubled, to \$290 million. IC prices have gone downward so dramatically that the number of units sold has tripled while dollar volume only doubled. At the present rate, 1967 will show a 600% increase in unit sales. It is hard to predict how much further prices will come down this year, so a dollar tag is hard to pin on; my 1967 estimate: \$650 million.

IC's get cheaper and cheaper. Average price is now under one-third that of 2 years ago. Sales for 1967 will be 6 times last year. More coming for home entertainment.

With IC's in the limelight, transistors might be expected to take a back seat. They are, but only in terms of sales *growth*. In 1966, 60% more transistors were sold than in 1965. The sale of transistors this year will be only 30% above last year. As with IC's, transistor prices are coming down, making dollar comparisons meaningless.

A recent transistor, the MOSFET (metal-oxide semiconductor field-effect transistor), is usurping high-impedance spots that were the next-to-last stronghold of vacuum tubes. The FET doesn't have the stability of other transistors, but look for that to be fixed soon.

Speaking of tubes, their *last* stronghold is in the power field. So far, no semiconductor can handle the power that tubes can at extremely high frequencies. Tube statistics suffer from the same thing that upsets semiconductor

statistics: prices are down. With tubes, there's another factor. Many consumer types now are multifunction—several tubes in a single envelope.

About 450 million tubes were sold in 1966; for 1967, it looks like 500 million. In power applications, in microwave, in special-purpose uses, and in CRT and image-storage spots, tubes will be around a few years yet.

Government electronics

The electronics industry's best customer is the US Government. Last year, the Federal Government spent \$9.5 billion on electronics equipment, research and services. If this year's trend continues, the tab for 1967 will meet or exceed \$10 billion.

Part of this is for equipment and components used in Vietnam, and part for defense electronics. Even more is spent on the space program. A hefty chunk of the \$6 billion spent yearly for space exploration goes into electronics. The total expenditure this year will be only slightly less.

The Gemini program ended last year, but moon-bound Apollo is still in full swing despite the tragic fire in Apollo 204 last February. Many dollars will be spent on Apollo electronics, both to accompany the mission and to support it.

Though the glamor is in reaching the moon, there is more importance to consumers in other space projects—the environmental satellites that plot weather, cosmic and other atmospheric data. These manmade heavenly bodies are busy exploring ways to make our lives on this planet more comfortable.

The space projects of foremost interest to RADIO-ELECTRONICS readers are the communications satellites: Syncom, Relay, Early Bird, to mention the most notable. Others to come will encompass the entire world with voice, data and television. Satellites and their ground-support stations use a lot of electronics.

Overseas markets

Electronics around the world affects the industry here in the US, from two standpoints: With shipping rates what they are, manufacturers in other countries find us an excellent market for electronic goods they can produce cheaper than we can. On the other hand, we find markets in foreign countries for electronic products we can produce better, faster, or cheaper than they can; often, our technology is far in advance of theirs.

Western Europe has shown spectacular growth in electronics over the last 5 years, coincident with the boom in its entire economy. But, from what we see at midyear, its growth rate is beginning to slow. Electronics there

will climb to well above \$6 billion this year. Last year it totaled about \$5.5 billion; that's a growth rate above 8%.

The best markets in Western Europe are for industrial controls, instrumentation and computers. Plants in Western Europe are also building up an impressive export trade in small parts: capacitors, resistors, and the like. For small parts, Europe is stiff worldwide competition to Japanese export trade.

Some countries of Western Europe, notably France and Spain, produce space electronics equipment. Switzerland has electronic watches, one with an IC. The United Kingdom and Portugal both are making an imprint on the communication and navigation equipment markets of the world.

Russia is a factor in electronics manufacturing. The Russian people are more able than ever before to afford consumer-electronic "luxuries." Electronic goods of all sorts are catching on in the consumer market, with television naturally leading. The Russians built 4.5 million TV sets last year and, as best we can estimate, will build around 7 million this year.

Japan and Western Europe are strong competition with us for world markets. Most significant Japanese imports to US are color TV and portable radios, especially latter (60% of all we will sell here).

In 1966 Japan shipped more than 1.5 million television sets to the US, about \$110 million worth. About 250,000 of them were color—over 5 times as many as in 1965. We will import about 600,000 color TV receivers from Japan in the current year.

Portable radios, both FM and AM, are the big Japanese contenders in the US electronics market. Of the 40 million radios that will be sold in the US this year, 60% will be imports. The Japanese will furnish the majority of that imported 24 million.

We've covered only the high spots. Many other things are happening in electronics. "Home" VTR's will make an increasing impact shortly, along with other products to help the consumer get more use from his TV receiver. Electronics is invading education even more. ETV is old hat; but new things are on the way: concepts like remote-access computerized research libraries, curriculum analysis by computer, new electronic teaching aids, etc. Holographic 3-D TV is near.

At the middle of the year, 1967, that's how the world of electronics looks from here. END

THE TECHNICIAN'S APPRENTICE

Off the busy, brand-new freeway
In the bustling downtown section
Stood the shop of T. Lokomis,
Our electronic tech Lokomis.
Back behind it rose the buildings,
Rose the sooty, grimy buildings,
Rose the stores with signs upon them,
Right before it ran the traffic,
Ran the buses and the trolleys,
Ran the trucks and all the autos.

There our eager T. Lokomis
Ran his thriving little business,
Greeted all his many clients
Bringing in their bad TV sets,
Quickly put them on his workbench;
Stilled their anxiousness by saying,
"Oh, I'll have it fixed in no time!"
Lulled them into waiting, saying,
"I will work on it tomorrow.
I am he the great Lokomis.
In my shop here in the city,
We will fix your ailing TV!"

Many things knew T. Lokomis
Of the circuits in the TV;
Of resistance and transmission,
Of impedance and reception;
Knew of purity, convergence,
Phase detectors and the chroma.
Taught his helper all his methods
With his soldering iron and wires,
Working far into the nighttime
In the chilly nights of winter;
Showed him all his many secrets,
How to fix the sets up quickly,
Going straight to fix the trouble—
Getting rid of snow and shadows.

At the door one springtime evening
Stood our tired T. Lokomis,
Smelled the pleasant air of springtime,
Heard the traffic rushing by him.
"Take vacation," said the springtime;
"Take vacation," said the traffic.

Said Lokomis, "Now, my helper,
I have taught you through the winter
How to fix a broken circuit
And replace the tubes and wiring;
You will work while I vacation.
Work with care, my trusty helper,
For our clients all are happy;
They are very, very happy
With the service we have given.
Now I leave on my vacation;
Work with care, now, in my absence
Lest we lose our loyal clients
Who depend on us to serve them."

But his trusted little helper
Loafing, loafing through the daytime
Did not get the work all finished—
Whispered, "Now I'll be in trouble,
I am sure I'll be in trouble.
Yes, Lokomis will be angry.
He will fire me and will throw me
Right into the busy traffic;
Out upon the street he'll throw me.
It's my body you will see there."

So he tried to work much faster
But he miswired all the circuits;
Whispered, "Woe is me, Lokomis,
I have failed you, wise Lokomis."

Came Lokomis from vacation,
Found the sets miswired, not working;
All the broken televisions.
"There's a mountain here of labor.
What has happened, trusted helper?
We cannot have service like this!"
So they worked and toiled till midnight
Working, wiring all the evening.

"Are we done?" then asked the
helper,
"Are we done?" he asked Lokomis.
And the good Lokomis answered:
"No, but we are making progress,
Talking will not get our work done
Talking, talking will not do it."

Then the tired little helper
Learned of every set its wiring,
Learned of tubes and of resistors;
What they did to make the sets work;
How they'd get the best reception;
Where to put a new antenna,
Worked with them in all his spare time,
Found them interesting problems.

Of all sets he learned the secrets
Learned the makes and all the models;
When the clients liked their work done.
So Lokomis and his helper
Finally got the work all finished.

Now the hurried little business
Has three times as many clients;
Keeps their sets repaired and working
All without annoying waiting.
Both Lokomis and apprentice
Know the ways to keep them happy,
Make the bills seem small and worthy,
So they're glad to pay up quickly.

And the happy clients voted
Them by far the best technicians
On the east or on the west side
Of the busy, rushing freeway.

By Phyllis Barlow

SOLID STATE IN

Part 1—Semiconductors control everything from food mixers to air conditioners—learn them now, for you may have to service them soon

By **THOMAS R. HASKETT**

YEARS AGO, WHEN ELECTRICAL PIONEERS first strung wires on poles from house to house, labor-saving devices began to appear. Soon electric appliances of every type were used by housewives, hobbyists, and workers on the job. Drills, vacuum cleaners, food mixers, washing machines—they constituted a revolution



Wen 950 drill with electronic speed control.

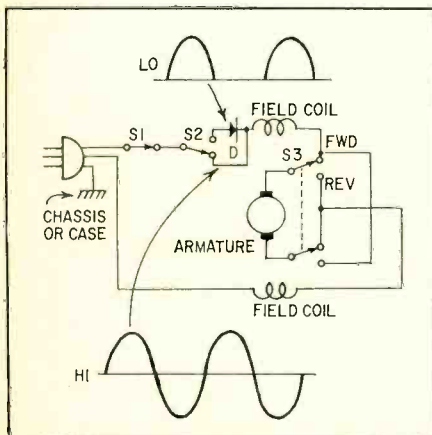

Fig. 1—Control circuit of the Wen drill.

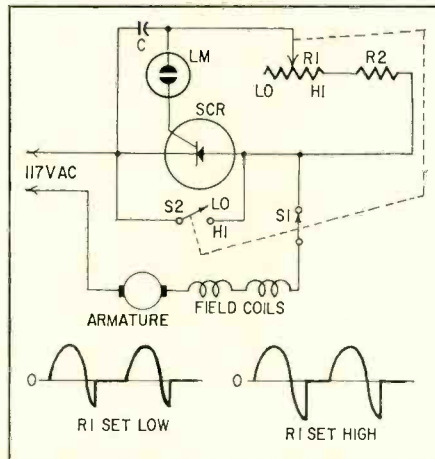

Fig. 2—Black & Decker power tools employ SCR to vary current to the motor.

in the process of getting work done.

Today another revolution is under way. The *electric* appliance is rapidly becoming *electronic*. Not long after the invention of the transistor in 1948, engineers were discovering new applications for solid-state devices. And when the SCR appeared . . . but I'm getting ahead of my story.

Motor speed control

Appliance manufacturers first used solid-state devices to advantage in power tools. One of the simplest, yet effective, circuits is shown in Fig. 1, the wiring diagram of the Wen model 950 1/2-inch All Drill. As the waveforms illustrate, diode D blocks current flow on negative half-cycles when S2 is in the Low position. Hence motor speed is cut in half. A mechanical gear change is used along with S2 to provide speeds of 630, 730, 2,200, and 2,400 rpm. All speeds are reversible by means of S3.

The circuit of Fig. 2 was devised to allow continuous speed control. It's used by Black & Decker in some of their power tools. The position of R1 determines the charging rate of C. Once C is charged to the firing point of the neon lamp, the lamp discharges C through the gate of the SCR, which unblocks and passes current through the

motor windings. This occurs every other half-cycle, and the point at which the SCR fires determines how much current flows through the motor, as the waveforms indicate. This, in turn, determines motor speed.

A single diode or SCR can control current flow only on alternate half-cycles. Hence the motor can be varied only from half to full speed. One way of obtaining full-wave control is illustrated in Fig. 3, the diagram of a six-speed saber saw. This circuit was patented by Alexander C. R. Wilson and John G. Lawrence of Black & Decker. At (a), with S1 on, S2 at position 1, and S3 in HI position, the saw runs at its highest speed. The equivalent circuit is shown at (b) with the voltage waveform opposite. Note that the motor field coils are in parallel.

When S2 is thrown to position 2, the motor runs slightly slower, and the circuit is converted to (c). Diode D1 is now in the circuit and limits negative current flow, as shown. The slight undershoot is due to the high reactance of the motor winding. When S2 is thrown to position 3, diode D2 is placed across the paralleled field coils (d) and eliminates the undershoot. Motor speed is slowed still more.

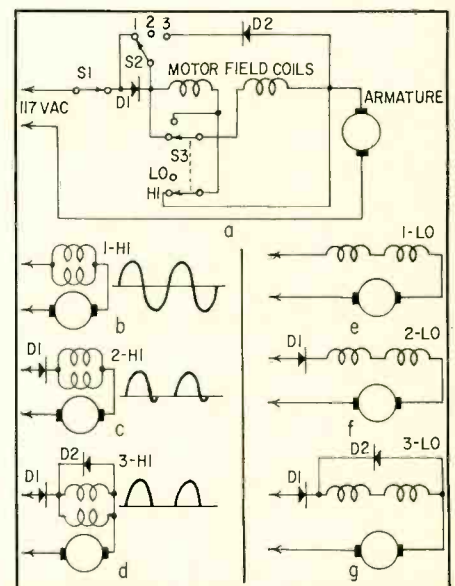

Fig. 3—Six-speed saber saw by Black & Decker uses field coils in series/parallel.

ELECTRIC APPLIANCES

With S3 at the Low position, the field coils are placed in series, as at (e). Thus motor speed is decreased still more. When S3 is thrown to positions 2 and 3, the diodes are again put in the circuit, dropping current flow and slowing the motor further.

When the motor speed of a drill or saw is decreased electronically, power and torque decreases (since gearing is still the same). Hence the amount of work that you can perform with the tool is less. You can't get something for nothing: If you have a tough job, like drilling through concrete, better get a geared-down slow-speed drill. Electronic speed control can be useful, however, for finer work in cutting, polishing and drilling. Power screwdrivers have less tendency to strip screwheads, and metal-cutting sawblades last longer at slow speeds.

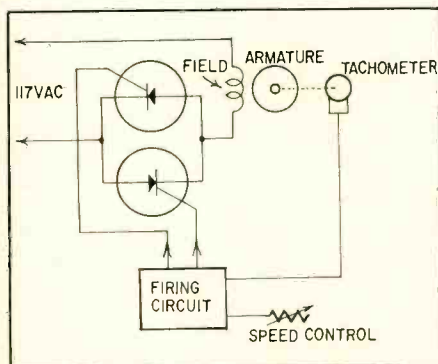

Fig. 4—Feedback holds drill speed even.

Most power drills, saws, sanders, etc. are free-running. That is, if you're drilling through wood and you hit a knot, the drill slows down. Fig. 4 shows the simplified circuit of a speed control with feedback. Here if the motor is slowed by a heavier load, the tachometer sends an error signal to the firing circuit which turns on the SCR's a little sooner on the cycles. This puts more current through the motor windings and restores the preset speed.

Drills and appliances aren't the only appliances with electronic speed control. Iona Manufacturing's R-14 food mixer allows the housewife to set beater speed exactly where she needs it.

When whipping cream, for instance, she probably uses a high speed to begin with. As the cream begins to form, however, she decreases speed so as to not overbeat.

Referring to Fig. 5, C and R1 in parallel provide a ramp-type reference voltage which is adjusted through speed-control pot R3. R4 is a limiting control, set at the factory so the motor will run efficiently at low speeds. The reference voltage is balanced against the residual counter-emf of the 140-watt universal motor through the SCR gate. If this counter-emf falls because the motor is slowed down (due to an increase in load on the beaters) the reference ramp triggers the SCR. This causes more voltage to be applied to the motor. The motor torque is therefore increased, maintaining speed.

In the model R-14, motor speed is



Portable food mixer by Iona Manufacturing.

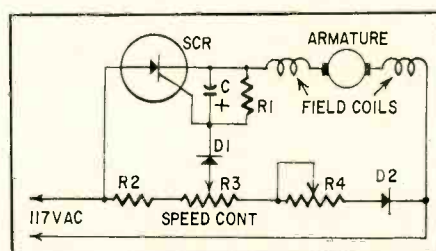

Fig. 5—Iona food mixer control circuit.

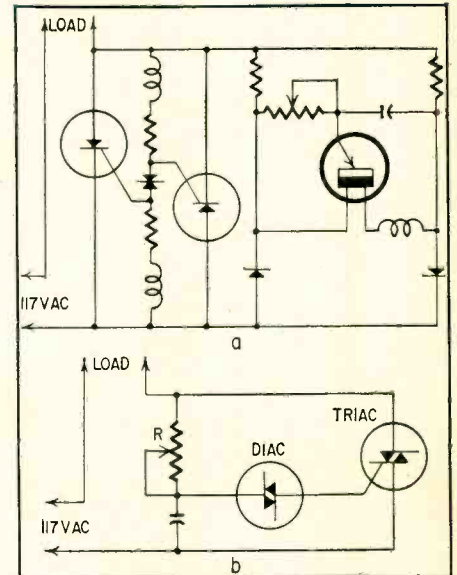

Fig. 6—Two SCR's (a) are needed for job that a single TRIAC (b) can accomplish.

continuously variable from 300 to 21,000 rpm. With gearing, this provides a beater speed range all the way from 20 to 1,200 rpm.

Since product designers wanted full-wave speed control over a wide, continuous range, they worked up some very sophisticated (and complicated) circuits. Fig. 6-a is an example. Two new solid-state devices, however, have simplified speed controls considerably. The first, shown in Fig. 6-b, is the DIAC, or ac diode. It works on both half-cycles of the ac waveform, and in this circuit is used to trigger a TRIAC, or ac triode.

The TRIAC (also known as a symmetrical ac switch, SGS, and Quadrac) is a five-layer (npnpn) device which can be triggered into conduction by a low-level device. Because the TRIAC is symmetrical, or bipolar, it fires in both directions and conducts on both half-cycles of the ac waveform. It's functionally the same as two SCR's in inverse parallel, but with the added advantage that only a single gate is used; hence only a single trigger source is required.

The circuit of Fig. 6-b, by the way, in addition to being used for motor-speed control, finds useful application in home lighting dimmers. It can vary lamp brightness from full on to almost

SOLID STATE IN ELECTRIC APPLIANCES

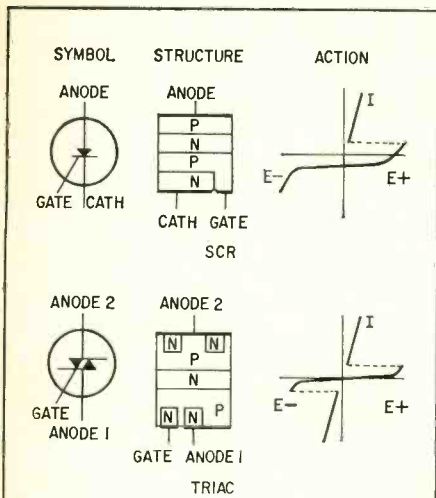

The appearance of the SCR—a solid-state equivalent of a vacuum-tube thyatron—made a large impact on the electronics industry. It means simple, reliable power control by a low-level trigger. But the SCR works only one way—only when anode voltage is positive (with respect to cathode) can the gate turn on the SCR.

The TRIAC (sometimes called a symmetrical gated switch) is roughly equivalent to a pair of SCRs reverse-parallelled. It can be gated on by both positive and negative pulses, regardless of which anode is positive and which is negative. Thus the TRIAC can pass current for any portion of an ac waveform.

There's a bonus, too. The TRIAC is inherently resistant to damage from line spikes or surges. Its five-layer configuration—a form of integrated circuit—gives it protection that an SCR doesn't have.

full off. It's better than single-SCR dimmers, because it allows full-wave—and full-brightness—control.

Temperature control

Housewives know that when roasting meat in an oven, the temperature inside the roast isn't the same as the general oven temperature. To correct this situation, Tappan uses a simple feedback circuit in their electric ranges. It's actually a second feedback circuit, for the oven contains a thermostat which auto-

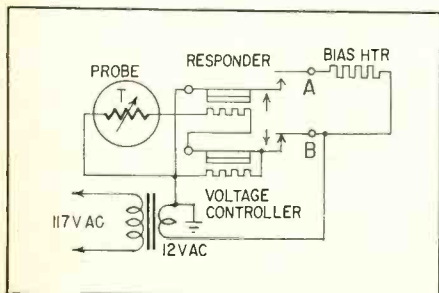

Fig. 7—Tappan oven-temperature circuit.

matically maintains temperature at whatever point the user sets it.

Referring to Fig. 7, the thermistor is mounted in a probe which is inserted in the roast. After the oven has been on a while, oven temperature exceeds inside-roast temperature. As the inside temperature rises, the thermistor resistance decreases, allowing more current to flow through the responder (a bi-metallic control). Eventually the responder closes contacts A, applying voltage to the bias heater. This heater is positioned near the oven thermostat and makes it hotter. At a certain point, when the temperature inside the roast has reached the "cooked" level, the heat applied by the bias heater to the oven thermostat is high enough to shut down the oven heater. The cutoff point can be adjusted through the range from "rare" to "well done."

The voltage controller is a regulating element, which maintains circuit voltage at 12 despite moderate line variations.

Another kitchen appliance that uses semiconductors to regulate temperature is the automatic icemaker. Most of us make ice cubes by freezing trays full of water in the family refrigerator. But suppose you're giving a party and need lots of ice?

An ingenious solution to this problem is Gibson Refrigerator's automatic icemaker. Using a single tray, it will make 4½ to 5 lb of ice cubes in 24 hours of unattended operation.

The circuit is shown in Fig. 8. The icemaker fits into the freezer compartment of a refrigerator, and when the storage receptacle (to catch cubes) is inserted, it closes cutoff switch S. Ac from transformer T is rectified by D1, stabilized by Zener D2, filtered, and set to the desired level by R4.

Current flows through both relay RY and thermistor R3 in parallel. As R3 is located in the bottom of the ice tray, it responds to temperature changes as the water freezes. A negative-coefficient thermistor, R3 increases its resistance with a temperature decrease.

When the ice is completely frozen, the resistance of R3 is great enough that most current flows through RY, pulling it in and connecting the motor winding across the ac line. The motor turns the commutator, making a "hold" connection to keep itself energized, and begins to turn the ice-cube tray. The commutator also opens the rectifier circuit, allowing the thermistor to recycle.

The motor performs three mechanical operations. First, one end of the tray is held tightly while the other end is twisted 23°, to break the cubes loose. Then the tray is rotated the other way to dump the cubes in the storage bin.



In 24-hour operation, Gibson automatic icemaker can produce 5 lb of ice cubes.

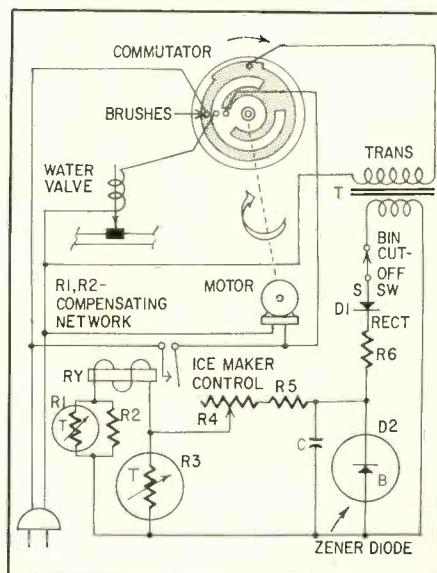

Fig. 8—Gibson icemaker uses thermistor control to sense freezing point of water.

Finally, the tray is returned to the "freeze" position. Since the tray is now empty, the water valve (actuated by the motor commutator) causes the tray to fill with water. The commutator then de-energizes the motor.

The icemaker recycles itself until the storage bin is full of cubes. Weight-sensitive switch S then opens the thermistor rectifier circuit, and no more ice can be made.

R1 and R2 compensate for environmental temperature changes. R4 is used to calibrate the device for any desired ice temperature.

Control of temperature and motor speed aren't the only things being done with semiconductors by appliance manufacturers. Example: A clothes dryer that senses whether clothing is wet or dry. It shuts itself off when all the moisture's gone. Tell you all about it next month.

TO BE CONTINUED

An Electronic Slave Flash for \$5

One of the flash photographer's most useful accessories. This one needs no camera connection

By EMERALD E. KEITH

NO DOUBT ABOUT IT: FOR SOME FLASH photos, you need more light—and more uniform light—than you can get with your camera-mounted flashgun. The pros use *slaves*—additional flash units mounted on tripods or clamped to some convenient object and triggered either by the camera or by the light from the camera flash.

The second method has it all over the first for convenience. You don't have to run wires between the camera and the slaves. The advantages of not having to do that are pretty obvious—especially to someone who *has* done it.

Here is a slave unit you can build in a few hours for ridiculously little money. The photos and the schematic tell almost everything you need to know, except for the show-stealer: Instead of an expensive light-activated SCR (LASCR), you can use an ordinary SCR with part of the case cut away to admit light.

To make an LASCR from a General Electric C6B silicon controlled rectifier (about \$2), file around and around the top edge of the case until the metal is extremely thin. Then, with a sharp knife, gently remove the top of the case. Try to avoid getting dirt or metal filings into the SCR. Once the top is off, drip three or four drops of clear epoxy cement into the void to fill it and protect the silicon wafer and connections from dirt and moisture. Use no more cement than necessary for protection; too much will reduce the light sensitivity of the new-born LASCR.

Let the cement harden. Then you can assemble the whole circuit into a miniature i.f.-transformer shield can ($\frac{3}{4}$ inch square by 2 inches). Mount a transistor socket for the LASCR by soldering its saddle to the rear part of a pilot-light assembly (see photos). This assembly must be large enough to clear the case of the LASCR, since the case is internally connected to the anode. The choke is a subminiature 1-henry unit with about 500 ohms dc resistance.

I epoxied a $\frac{1}{4}$ -inch x 20 nut to the side of the i.f. can. That fits the threading on standard photo tripods and light stands. A replacement flash connector (available from camera stores—or improvise!) is convenient for connecting the slave trigger to the slave flash unit itself. Of course, the LASCR unit can be built into a flashgun barrel!

Credit for the circuit must go to General Electric's application note 200.34.

If you use the slave trigger with BC or straight battery-and-flashbulb units, the bulb may flash when you first connect the trigger. Sensitivity control? None needed. The choke automatically compensates for any differences in ambient

light level in the scene.

I've built three of these. They all worked very well outdoors, and indoors up to 20 feet. I've never needed greater distances, but the slaves should work well with quite a bit more separation. END

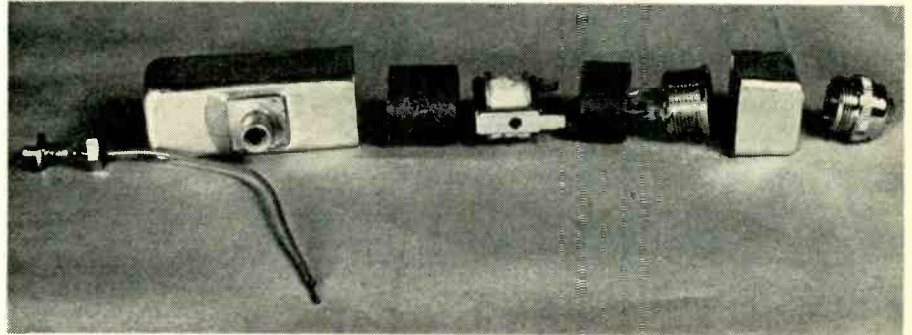

From left to right, these are the parts that make up the mechanical assembly: gun connector and lead; case with mount; fiber spacer; choke; another fiber spacer; pilot-lamp socket, transistor socket attached (contains LASCR); case top; pilot-lamp and jewel.

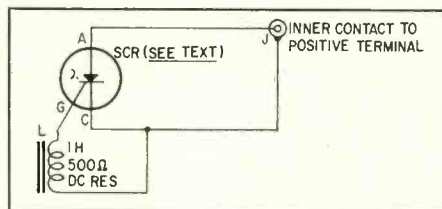

This is the complete schematic of the flash slave unit. Coil can be made from transistor radio output transformer (when rewound).

- J—standard photoflash connector, or two-conductor connector of your choice
- L—1 henry, 500 ohms
- LASCR—General Electric C6B silicon controlled rectifier, modified according to text
- Shield can from discarded i.f. transformer
- Pilot-light assembly and jewel
- Miscellaneous fittings and fiber insulators (see photos)

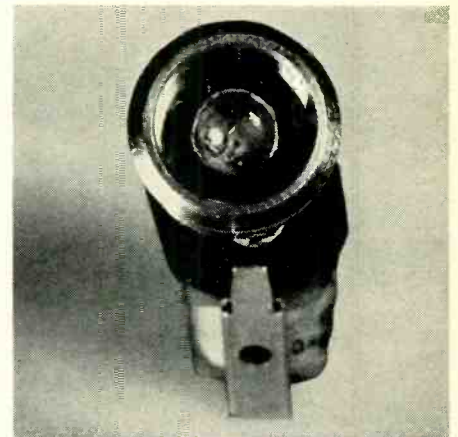

Looking into the homemade LASCR top.

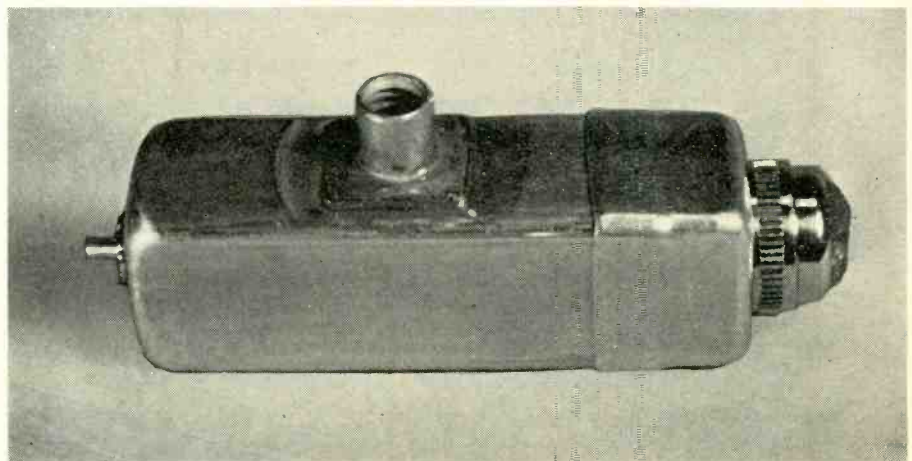

A new little package is the completed flash slave unit shown in its i.f.-can container.

Burglars Got It Bad—And That's Good

Every time you leave your home or office, you are a potential theft victim

By JACK DARR

EVER SINCE NERVOUS GEESE WERE KEPT to warn of intruders, men have sought to design the perfect burglar alarm. Early devices were mechanical, linking cords, cables and cowbells. But the first really practical alarm systems were electrical. A series circuit was formed all around a building using metal tapes. When the circuit was complete, current flowed through the loop. If a burglar broke the foil by cutting a windowpane or opening a door, the circuit was broken and a relay-operated alarm was energized.

An alarm of this type can be defeated easily. A wire jumper placed across one section of foil will permit easy removal of a door or window. The thieves can then clean house without being disturbed.

Fortunately for the beleaguered property owner, a new family of electronic alarms has come to the rescue. Relatively simple devices furnish completely tamperproof protection for homes, stores and offices. Strangely enough, these electronic alarms operate by taking advantage of actions (or "mis"-actions) that technicians and troubleshooters labor to remove from radios, TV's and communication equipment. The principles applied to alarms literally are "backward" electronics! As we discuss the various systems, you'll see what we mean.

The oldest electronic sensing device used in simple alarms is the photocell with its familiar light beam. This is the same approach often used to open the doors in your favorite supermarket. A light beam falling on a photocell can be made to open or close a relay. When the beam is interrupted, the cell reacts. Some types change their resistance, others develop a voltage. In either case, the altered characteristic is used to operate the relay and set off the alarm.

Early photocell alarms could be defeated simply by shining a light on the cell to hold the relay closed while the thief went to work. Improved types, however, can be set to respond only to a predetermined light level; more or less light will trip the alarm. The device in the photo above is designed specifically as a fire alarm. The cell and light source are balanced electrically during installation. If smoke gets into the unit, the level of light falling on the cell is cut down, and the alarm sounds.

This unit also has temperature sensors inside the case for added protection. They close to sound the alarm when the temperature reaches 130°.

Circuitry is transistorized and powered from the ac line. Designed for home use, the unit requires no special installation—just set it down and plug it in.

There also are photoelectric burglar alarms. One system uses an invisible beam of modulated infrared light. A transistorized 55-Hz oscillator in the transmitter unit modulates the filament of the sealed-beam IR lamp. A 55-Hz signal was chosen instead of the 60-Hz line frequency to keep an intruder from defeating the system by shining the light from a 60-Hz stroboscope into the receiver.

This alarm uses a phase-sensitive detector in the receiver to demodulate the beam. A full-wave bridge compares two 55-Hz signals: one, a reference signal taken from the oscillator in the transmitter; the other, the detected output of the photoelectric cell. As long as the two signals are present and in phase, the alarm will remain silent. Any other IR light source, such as might be used by an intruder in an attempt to fool the system, would not be phase-locked. The alarm would sound.

The cell used in the infrared detector is a specially designed phototransis-

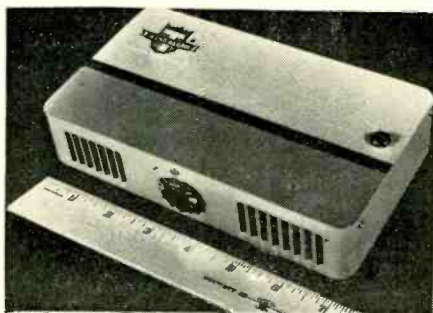

Photocell-activated fire alarm for home use is compact and sensitive to smoke.

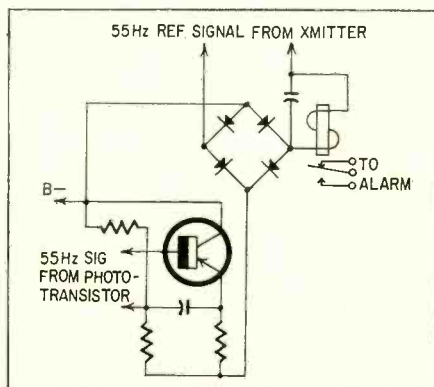

Fig. 1—Bridge circuit compares phase of reference oscillator and incoming signals.

tor with a response peaked in the 2-micron range, high in the infrared region. It also gives a higher output with modulated (ac) light input than with "pure dc" or constant light. The efficiency of the system is thus improved and effective ranges as great as 700 feet are possible.

Fig. 1 shows a simplified schematic of the phase detector. The amplified signal obtained from the phototransistor is used to drive the base of the phase-detector transistor. Emitter-collector voltage comes from the bridge rectifier, driven by the reference signal obtained from the 55-Hz oscillator in the transmitter. This current flows through the dc relay used to activate the alarm circuit. The 55-Hz oscillator supplies both the modulating signal for the IR lamp and the reference signal for the detector. The signals fed to the bridge will therefore be locked in phase. A small phase shift, due to the thermal lag caused by the lamp filament, is balanced out by a compensating network in the receiver.

The total dc collector current of the phase-detector transistor is relative to the sum of the instantaneous voltages appearing on the base and collector. Collector current and the driving voltages must always be in phase to provide sufficient dc voltage to keep the relay closed.

In the absence of light or with an unmodulated light beam, output of the detector will be zero. The reference voltage will still be present, but the phase-detector transistor will lose its base bias and be cut off. Current through the relay coil will be only the sinusoidal current from the 55-Hz oscillator; the dc relay will therefore drop out and the alarm will sound.

If the base and collector voltages are out of phase, which could happen if someone were trying to use a substitute light to defeat the alarm, output from the detector would be reduced due to the phase difference. Detector output depends on both voltages being exactly in phase, so the relay opens and sounds the alarm.

Proximity detectors

The "proximity" or "capacitance" detector is another basic circuit often used in alarms. This is a good example of the "backward" electronics approach. Normally, we build an oscillator to be as stable as possible. In this type of alarm,

the whole idea is to construct a highly unstable circuit. If part of the circuit is external to the unit itself, it can be made to respond to external objects. Anything moving into the field of the detector will contribute to the total circuit capacitance and cause a circuit change that will cause the alarm to sound.

Fig. 2 shows a typical system set up to protect a row of filing cabinets. The metal cabinets are connected together by jumper wires and constitute part of the "antenna" loop. They actually become part of a balanced bridge in the circuit detector. Standoff insulators between cabinets and the floor reduce the capacitance to ground to make the system more sensitive. As many as 40 cabinets can be protected at one time using a single unit.

The heart of the system is a balanced Wheatstone-bridge circuit in the detector. The source signal for the bridge is a 20-kHz transistorized oscillator. Capacitance of the protected objects to ground forms one leg of the bridge. This part of the bridge is balanced by using a fixed capacitor of equal value in the second leg. The other two legs are resistors, one of which is variable for balancing the bridge at time of installation. Several capacitors are provided for balancing the circuit if the number of cabinets being protected is changed.

Sensitivity of the device is such that, in normal operation, the alarm will trip when any person approaches within 6 inches of the cabinets. If many cabinets are to be protected, this distance will decrease to about 1 inch, or sometimes until the intruder actually touches a cabinet. Alarm action always is positive, however.

Ultrasonic alarm systems

Ultrasonic (high-frequency audio) signals are used in another family of alarm systems. Using radiated sound waves in the 20-kHz range, such devices can sense movement within a surprisingly large area. The dome-shaped objects seen in the photo are special high-frequency speakers and pickups (microphones).

The high-frequency sound waves radiated from the speakers are generated by magnetostrictive rods driven by a power amplifier. These nickel-alloy rods expand and contract when driven by an ac signal of sufficient strength. Sound-wave patterns are thus set up by the rods. A master oscillator in the amplifier unit provides the drive signal for the rods and also supplies a reference signal for the detector in the receiver unit. A phase-detector circuit similar to that discussed for the proximity detector is used in this system. With an auxiliary power amplifier, as many as 24 speakers

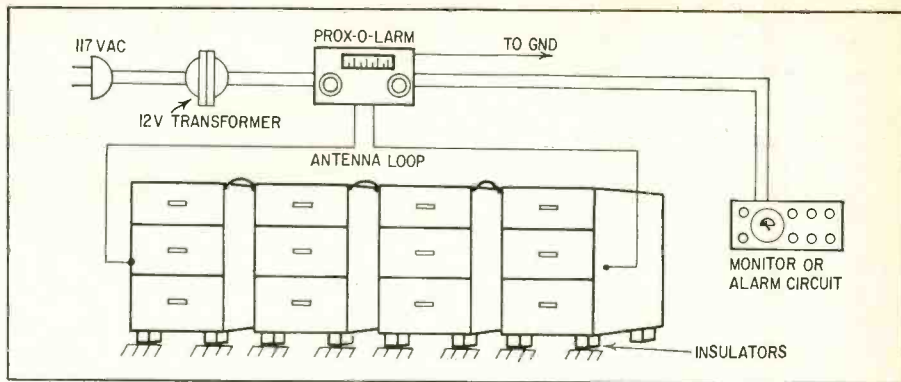

Fig. 2—Cabinets being protected become part of balanced-bridge circuit in the detector.

can be used to cover areas of 10,000 sq ft and more.

Due to the domed shape of the radiators, sound waves travel from them in all directions. Reflected by the walls, floors, furniture and any other solid surfaces, they form a pattern of standing waves in the protected area. This sound pattern is picked up by the microphone units and fed into the receiver. The receiver's phase detector compares the incoming signal with the reference signal supplied by the master oscillator. When the sound pattern is stabilized, the detector is balanced so the relay won't be tripped.

When an intruder enters the protected area, his body absorbs a portion



This alarm uses modulated infrared light to avoid detection or disabling by thieves.



Ultrasonic transducers transmit a sound pattern completely covering protected area.

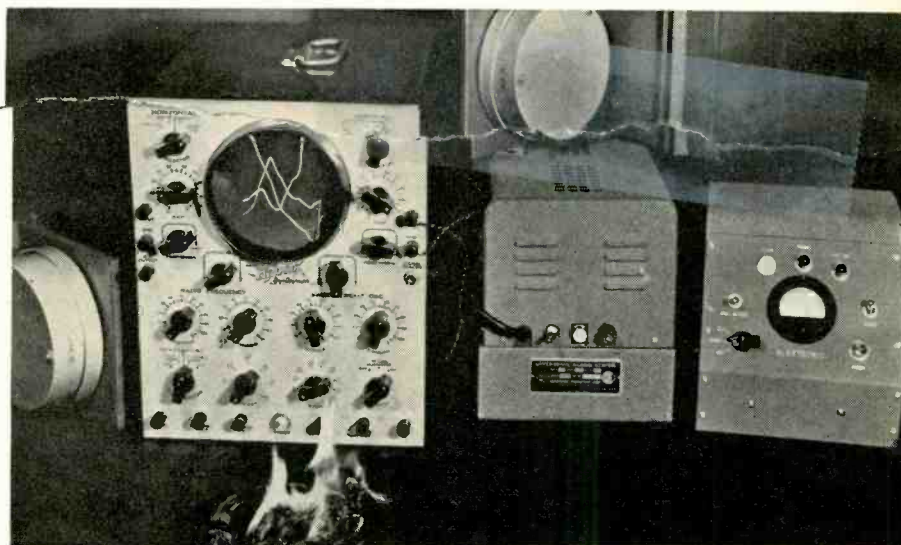

Movement of air between transducer heads caused by heat convection triggers alarm.

Burglars Got It Bad—And That's Good

of the sound energy within that area. The sound pattern is altered enough that the change can be sensed by the receiver's phase detector. The relay trips, the alarm sounds. System sensitivity can be adjusted so precisely that small moving objects—guard dogs, for example—can enter a protected area without being detected; anything the size of a human intruder, however, will set off the alarm.

Sensitivity of this system is so great it can serve as a fire alarm. As seen in the accompanying illustration, the pattern on the scope is the alarm signal. The disturbance which caused the pattern is the small scrap of paper burning in the ashtray. This minor blaze changed the sound-transmission characteristics of the air between the speaker and pickup units and tripped the alarm.

A miniaturized, fully portable version of this system also is available. Pickup and speaker are mounted in the same case, one at either end. The lightweight unit can be installed temporarily to protect jewelry cases, cabinets or files containing any kind of valuable material. It also can be used permanently installed to protect small rooms. Sensitivity is such that a person standing absolutely still 12 feet away won't trip the alarm, but when he takes so much as one step—bingo, the alarm sounds.

An externally mounted 12-volt transformer provides the required input power. A built-in battery, on trickle-charge at all times, offers an automatic fail-safe power source.

Uhf radio alarms

Another class of alarms is similar to the ultrasonic type, in that an area is "flooded" with radiated signals. In these units ultra-high-frequency radio waves are used instead of ultrasonic sound waves. The method of detecting the pattern is slightly different, too.

The block diagram of a typical uhf system is shown in Fig. 3. A single-tube uhf oscillator is coupled to the antenna.



Uhf signals radiated from antenna set up rf field throughout the protected area.

Rf energy is radiated into the surrounding area. In conventional transmitters, the signal for the transmitting antenna is never fed directly from the oscillator. Any change in the field of the antenna would affect its loading and thus the frequency of the oscillator. In this uhf detection device, however, we do this deliberately. The antenna and its surrounding field are the "load" on the oscillator. If anything changes within this field, the changed loading will be reflected to the oscillator. This frequency change can then be detected and used to operate the alarm.

A high value of load resistor is used to feed dc power to the oscillator, another uncommon application. Normally, we choose the smallest possible value to avoid voltage variations. In this application, since we want variations, a coupling capacitor is connected to the top side of this resistor. Any variation in oscillator current will initiate a small signal pulse at this point.

When the transmitter is turned on,

the area to be protected is flooded with rf energy. Reflections, standing waves, etc. will form in the entire area. When the reflected standing-wave pattern stabilizes within a split second, the oscillator is tuned up. The surrounding free-space rf field is actually the loading on the antenna and, by transfer, on the oscillator.

If an intruder enters the rf field, the standing-wave pattern is altered. This in turn changes the oscillator loading. Oscillator plate current changes are reflected at the top of the load resistor as a tiny pulse. This pulse is fed through a specially designed low-frequency amplifier and appears at the grid of a thyratron relay-control tube. The thyratron fires to close the alarm relay.

It's well known that anything at all in the "near field" of a transmitting antenna will affect the field pattern. Very few things are absolutely transparent to radio waves; no matter what an object may be, it will change the standing-wave pattern and the load-impedance of the antenna. When this occurs, the alarm will sound.

Normally, the rf field will not react to fire or heat, unless the smoke contains a very heavy concentration of carbon particles or water vapor. However, external sensors can be plugged into the alarm system to add such protection. The sensors are small bellows-type thermostats designed to react to rapid changes in temperature. They also are equipped with contacts that will close if the ambient room temperature rises above a preset level.

The "necktie" detector

The "wildest" detector of all, although not yet on the market as a commercial alarm system, is a device originated by Gordon J. Murphy of the Electrical Engineering Dept. of Northwestern University. The device was built by Ted Johnson and George Rabindran as part of a project. It's called a Pattern Recognition Feedback Control System or PRFCS. PRFCS has a TV camera mounted on a motor-driven, fully gimbaled head capable of 360° horizontal and 270° lateral movement. A small digital computer records the bit pattern of any object seen by the camera, allowing it to "recognize" any preset pattern. Once a pattern has been stored in the computer's memory, the eye can be directed to hunt for it until it finds it. Once the pattern is located, the eye will lock on and follow it until it goes out of sight. Johnson actually has trained a PRFCS to follow his necktie!

The unit also could be trained to follow any moving object of specific characteristics. Infrared sensors would let it see in the dark, and it could have significant industrial applications. END

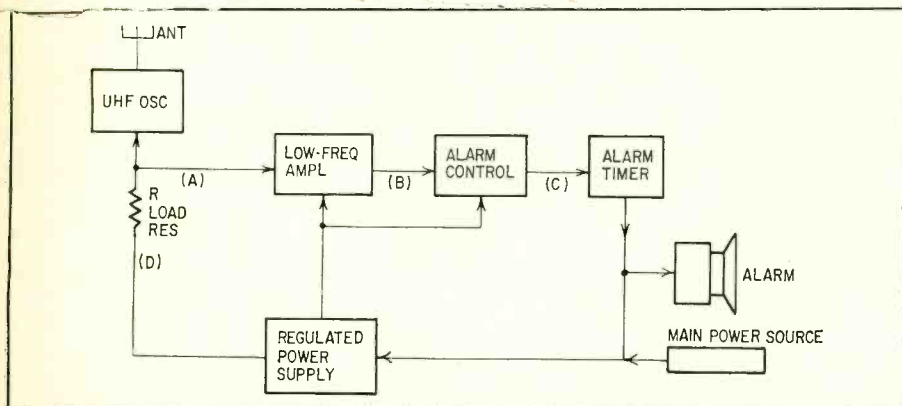

Fig. 3—Uhf oscillator both transmits signal and detects any disturbance of rf pattern.

BAFFLE: Speaker-Air Interface

An acoustic coupler, it matches the generator (speaker) to the load (air)

By JAMES F. NOVAK*

HIGH-FIDELITY SOUND WAVES ARE NOT PRODUCED BY LOUDSPEAKERS alone but by a combination of speakers and baffles. Loudspeakers generate sound by creating small changes in air pressure. They do this with a moving diaphragm that alternately compresses and rarefies the air surrounding it. These local pressure changes (or sound waves) then travel from the speaker in exactly the same manner in which ripples travel from a stone dropped into a pond.

The moving diaphragm generates sound waves both in front of and behind the speaker. Unfortunately these two sets of sound waves are opposite in character—when the front of the cone generates a high-pressure wave, the back of the cone is generating a low-pressure wave. These two waves tend to cancel each other when they are not isolated, and this tendency becomes greater as the frequency becomes lower.

Baffle—verb: *to defeat the efforts of by interposing obstacles.* That dictionary definition clearly explains the mechanism by which a “baffle” permits or improves the generation of low frequencies by the loudspeaker. The purpose is to separate or isolate the front and back waves and thereby prevent them from canceling each other. Some baffles separate the two sound waves at all frequencies, others only throughout part of the frequency range, while still others actually reverse the character of the rear sound waves and cause them to reinforce those from the front of the speaker cone.

*Senior design engineer, Jensen Mfg. Div., The Muter Co.

One important point to remember is that once a speaker is baffled, the main factor that determines the low-frequency cutoff is the resonant frequency of the speaker, or its resonance in the baffle, or even a new resonance created by the presence of the enclosure.

The idea that all resonances are bad and must be heavily damped is all wrong. Although *some* resonances do cause problems, the fundamental speaker and cabinet resonances, when properly located and controlled, will spell the difference between poor and excellent low-frequency performance. This is illustrated in Fig. 1, which shows the response of a speaker in either an infinite baffle or a closed box.

The solid curves represent most quality high-fidelity speakers. The dotted curve represents a cheap small-magnet speaker, and the dashed curves illustrate what happens when Q is reduced by much damping. The output of the speaker drops to $\frac{1}{10}$ (20 dB) of its flat value at 100 Hz for $Q = 0.1$. The low-frequency performance of this speaker-baffle combination is determined solely by the frequency and strength of resonance. Nothing will increase the output at 40 Hz except a decrease in resonant frequency which will move the curves physically to the left. An increase in the frequency of resonance will move the curves physically to the right.

The large number of existing baffles, enclosures and speaker cabinets may be reduced to the five basic types shown in Fig. 2, with perhaps this many variations of most of them.

Infinite baffle: This name is attached to perhaps the greatest number of enclosures. Actually, most fall far short of true infinite-baffle performance. Such an enclosure does not raise the resonant frequency of the speaker over that measured in

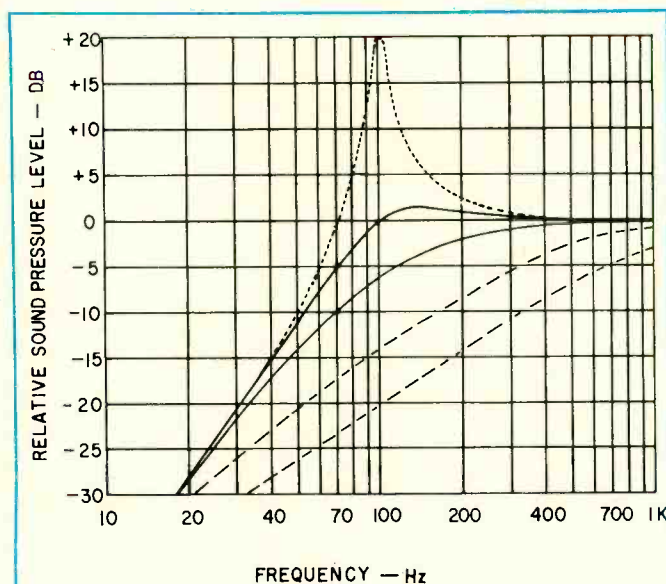

Fig. 1—Curves of sound-pressure levels of a baffled speaker,

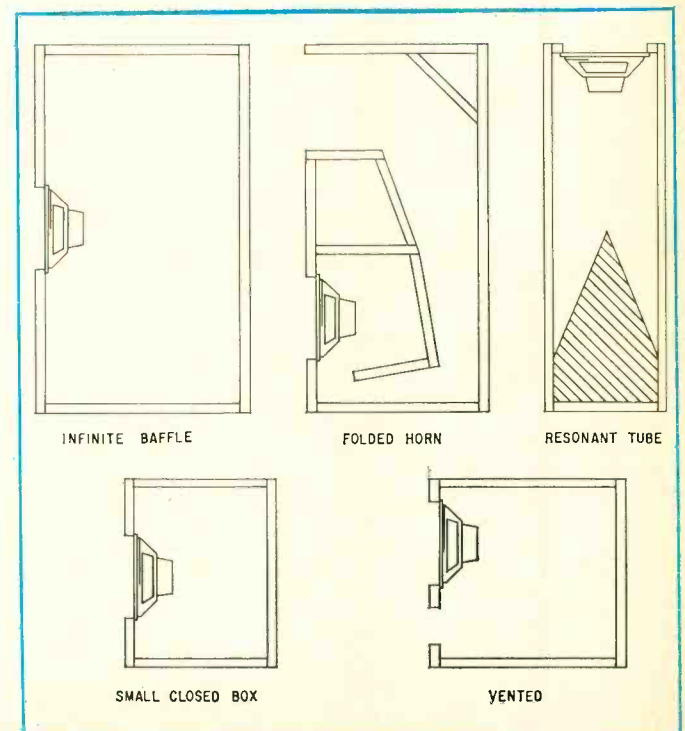

Fig. 2—There are five basic patterns of loudspeaker enclosures.

BAFFLE: Speaker-Air Interface

free air. It lowers resonance due to additional air loading.

The dictionary defines *infinite* as "quite large." Speakers mounted in holes cut through walls between rooms, or speakers installed on the inside of closet doors, see infinite baffles. There are practical problems, however: Although both rooms get sound from the speaker mounted in the wall, only one room gets high-fidelity sound. The high frequencies radiate only into the room which sees the front of the speaker. Closet doors are very seldom located in the proper place; furthermore, where does one find two closet doors properly located for stereo?

A flat baffle will operate as an infinite baffle at frequencies for which the distance between front and back of the speaker is at least $\frac{1}{2}$ wavelength. Of course, frequencies lower than this will suffer the same cancellation. This type of baffle is not very useful for high-fidelity applications, though, because of the great size required. To obtain reasonable performance—to, say, 40 Hz—the length of one side must be at least 14 feet.

Perhaps the most common baffle for speakers is the open-back cabinet. It is really a flat baffle with the sides folded back, and performance is very much the same up to frequencies where the depth exceeds $\frac{1}{8}$ wavelength.

One of the most troublesome characteristics of this type of baffle is a resonance associated with the volume enclosed by the sides. Called cabinet resonance, it enhances the motion of the speaker cone; hence the output is increased. Problems arise because the cabinet resonance usually occurs in the 100- to 200-Hz region, causing an unnatural-sounding "boomy" quality. This effect becomes more pronounced as the cabinet depth is made greater.

A practical limit to the size of a closed-box type of infinite baffle is that volume beyond which further increases make no appreciable difference in the fundamental speaker resonance. It was stated before that a true infinite baffle

does not raise the resonant frequency of the speaker above its free-air resonance. The volume must be quite generous for this to occur. For most 15-inch speakers, for example, a 15- to 20-cubic-foot enclosed box would be "infinite" in a practical sense.

The radiation from the back of the cone tends to set up patterns of standing waves inside of large closed boxes. These standing-wave resonances interfere with the motion of the speaker cone and introduce sharp peaks and dips in what could be a smooth response. These resonances can be reduced or eliminated by lining the inner surface of the cabinet with a thick layer of sound-absorbing material. A 3- to 4-inch thickness of glass-fiber insulation works admirably well. This layer of absorbing material will have little or no effect upon the fundamental speaker resonance.

All the preceding baffles can give excellent results if they are large enough. This requirement of great size is the most important single reason why baffles of this type are rarely found in modern high-fidelity practice.

Small closed box: This type of baffle does have an appreciable effect upon the resonant frequency of the speaker because of the stiffness of the air behind the cone. This air acts as a spring which raises the resonance as much as 3 or 4 times the free-air resonance. For this reason most bookshelf-size boxes have specially designed speakers with very low free-air resonances.

The effect of this "air spring" is an inverse function of cabinet volume and speaker diameter. For example, doubling cabinet volume reduces the effectiveness of the spring to $\frac{1}{2}$ and decreasing the speaker diameter to $\frac{1}{2}$ reduces the spring effect to $\frac{1}{16}$ its former value. These steps permit lower speaker-system resonances and, as previously stated, the resonance determines low-frequency cutoff. Hence the best-sounding bookshelf speaker systems are either too large to fit on a bookshelf or use 8- or 10-inch woofers. Speakers as large as 15 inches are rare in this type of baffle.

Because of intensive design work on very small speaker enclosures during the past 10 years such systems are now widely accepted by critical listeners. The low efficiency of the small closed box is a natural consequence of designers' efforts to lower the resonant frequency of the speaker.

The smaller cone demands large voice-coil excursion capabilities which in turn requires a long, heavy voice coil. Because most of the voice-coil wire is outside of the magnetic air gap, efficiency suffers. The heavier voice coil (and, in many cases, cone) lowers the resonance—and also the efficiency. Some closed boxes are completely filled with glass fiber. This makes the volume appear larger but introduces acoustic resistance. Resistance in any circuit reduces efficiency (because it wastes power). Still, the amount of bass produced by such a small enclosure can be amazingly adequate. A fact of life must be pointed out here, however: A large box allows *more* and *cleaner* bass than a small box.

Resonant tube (or column): It operates on the same principle as an organ pipe. The tube (or pipe) resonance makes the volume appear larger; the speaker resonance is therefore lower. The tube can have either an open or closed end opposite the speaker. The closed-end tube might be considered a special case of the closed box in which one dimension becomes very large. The labyrinth is an open folded tube using radiation at the open end to reinforce output from the speaker end. These baffles are usually highly resonant at several frequencies and must make liberal use of acoustic absorption material.

Horn: True horn loading increases the radiation-resistance loading and output of the speaker over a relatively wide frequency range. No other enclosure can deliver so much output at such low distortion over such a wide frequency

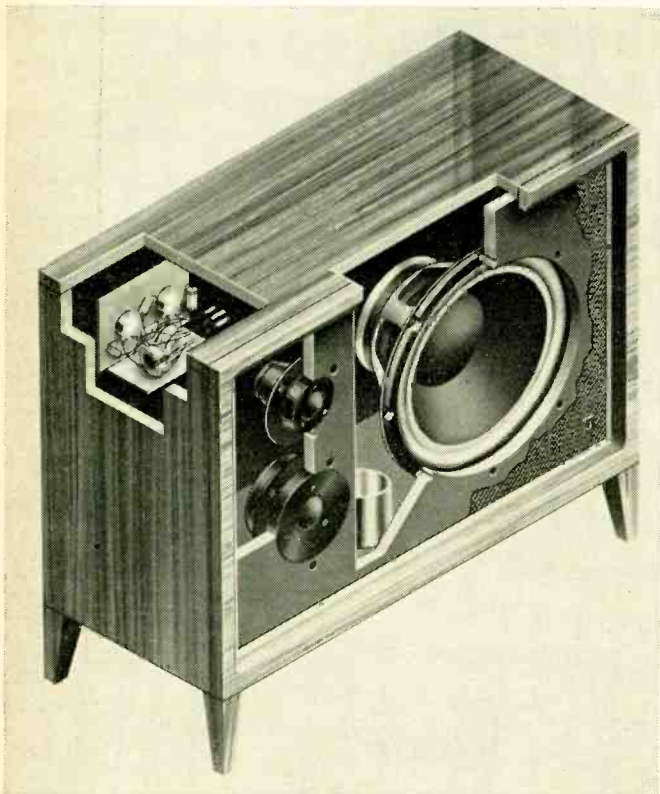

Typical of a popular type of enclosure, this duct-load bass-reflex unit uses a duct firing out of the bottom of the box.

range. Many enclosures labeled as horns are deficient in flare path length, mouth area, or other characteristics so that they operate in some manner other than a true horn. Here again, as in the infinite baffle, the enclosure must be very large to reproduce the lowest frequencies.

Horn loading utilizes an expanding tube between the speaker and the air to match the normally high impedance of the speaker to the low impedance of the air. The present state of the art does not permit the design of speakers which will match air impedance and still cover even a moderate frequency range. Thus, the transformerlike action of a horn is necessary for high-efficiency performance.

Unlike the simple baffle, the horn requires a speaker operated *below* its resonant frequency over a substantial frequency range. Operation below resonance in a simple baffle results in very low output and high distortion.

There are two methods of constructing low-frequency horns. In one, a sealed cavity is placed over the speaker back. This has the advantage of permitting adjustment of speaker resonance to that value producing the widest frequency range through variations in the cavity volume. The disadvantage is that the higher frequencies tend to get lost inside the horn—especially if it is folded to conserve space.

In the second method, the front of the speaker is allowed to radiate directly into the air and the horn is coupled to the rear of the speaker through a cavity. The advantage of this technique is being able to use one speaker to cover a wide frequency range without losing any of the higher frequencies.

Horns are named by the manner in which they taper or expand. Three useful tapers are (1) conical, (2) exponential and (3) hyperbolic-exponential. Of these the hyperbolic-exponential is the most efficient down to the lowest frequencies—although the exponential does enjoy wide usage.

Further discussion of the operation of a horn is quite involved and outside the scope of this article. The easiest thing to remember is that good low-frequency horns must be large. For instance, a 40-Hz horn could very well have a 9-foot diameter mouth (open end) and a length almost 1½ times that.

Bass reflex: This enclosure is very much like a closed box except that it has an opening cut into it, usually on the front of the enclosure. This opening allows rear waves to emerge from the front. But, unlike the flat baffle or open-back cabinet, cancellation does not take place. A tuned circuit is created by the mass of the air in this opening (called a port) and by the compliance of the air inside the box—both of which shift the phase of the sound waves so that they reinforce those from the front. The cabinet-and-speaker combination actually becomes a system of two very tightly coupled tuned circuits. As usually happens in overcoupled circuits, the original resonance is replaced by two others, one above and one below the speaker resonance.

The enclosure acts as a very small flat baffle at frequencies below the lowest resonance since the sound waves from the port and speaker are opposite in character. About midway between the two resonances, most of the sound is generated by the port while the cone almost stands still. At the upper resonance, the port and cone aid each other, resulting in an increase in total sound output. At still higher frequencies, the enclosure acts as a closed box—as if the port was not there.

A common misconception is that the enclosure can be made much smaller by using a duct or tube behind the port. While the use of a duct allows one to tune the enclosure to very low frequencies when volumes are small, the low-frequency cutoff is determined by the ratio of enclosure air stiffness to speaker suspension stiffness. As the enclosure volume is decreased, the air stiffness increases and so does the cutoff frequency. This remains true regardless of subsequent

tuning of the enclosure.

A second misconception is that any closed box will perform better if it is ported for bass-reflex operation. Some boxes are too small and some too large for porting. A too-large box will give rather “boomy” bass rather than an extension in cutoff. A too-small box, on the other hand, will shift the low-frequency cutoff upward; this causes a loss in low-frequency output. Such boxes should be left closed.

Best results are obtained if the volume of a bass-reflex enclosure is such that the free-air resonance of the speaker is increased about 1.6 times in the unported box. This size enclosure, when properly tuned, gives the most extended low-frequency response and greatest freedom from hangover (boom), assuming sufficient damping exists. Compared to the completely closed cabinet, the half-power point (3 dB down) occurs at about 0.7 the closed cabinet speaker resonance—which is a low-frequency extension of about ½ octave.

The use of ducts or tubes behind ports is not as mysterious as it sounds. A port is really a duct or tube with a length equal to the cabinet wall thickness. The frequency to which the enclosure is tuned should be the free-air resonance of the speaker and is obtained by varying the port and/or tube dimensions. The cabinet resonance increases as port area increases and the resonance will decrease if the tube is made longer.

The choice of a port alone or a port with a tube often depends on the computed size of the port alone. Often the required resonance is so low that the port area is only a few square inches. A small port is inefficient and air rushing through it makes whistling noises. In these instances, the port is arbitrarily increased in size and the proper resonance is obtained by putting a tube behind it. Although no single baffle type will give the ultimate in performance for all types of speakers, the bass reflex is about the most useful from the standpoint of cost, complexity and performance. [For the full treatment on bass-reflex enclosures, see the nine-part story “All About the Reflex Enclosure” in the February and April through November 1959 issues.—*Editor*]

The most important factors in speaker enclosure construction are rigidity and airtightness. The baffle is *not* a sounding board like that used on a piano to amplify sound. It should be clear by now that the baffle is a device for controlling sound waves created by the back of the speaker cone. Any vibrations in the cabinet panels absorb power and can reradiate sound waves of their own. This can create rattles and large holes and peaks in the response curve. Therefore, minimum material thickness should be ¾ inch on all sides, including the back. Small cabinets may sometimes be able to use ½-inch material. At other times even ¾-inch material will be adequate and bracing will have to be used.

The best test for rigidity—whether building or buying an enclosure—is to thump the center of all panels with a clenched fist. A vibrating panel will sound hollow and drummy, indicating a need for further bracing.

All joints in all enclosures, horn and bass-reflex designs included, must be airtight. The best enclosures make liberal use of wood screws and glue for making joints tight, and caulking compound for insuring that they remain airtight. The loudspeaker units should also be fastened tightly to the baffle so that no air can leak from front to back. Air leaks will impair the low-frequency performance of the speaker-baffle combination.

In conclusion, it is well to remember that the old truism “you don’t get something for nothing” applies nowhere more than to baffles used for bass reproduction. Sizable clean (low-distortion) output over a wide range of low frequencies in a well-balanced system with good efficiency requires that the enclosure be quite large. The small enclosure can incorporate some of these features but only at the expense of others. END

Special Sounds of Organ Music

By RICHARD H. DORF*

ONE OF THE FANCIEST BOXES OF TRICKS available to the average person is the modern electronic organ. It outsells the piano because it's easier to play. Unlike other instruments, an organ responds to an elementary type of button-pushing.

When you press a button known as a key, for instance, the volume doesn't depend on how quickly or how hard you push, as in a piano, and the pitch doesn't depend on precisely where you place your finger, as on a violin. If you want a sound like an oboe or a flute, the organ doesn't require you to learn any delicate manipulations of lungs and lips; all you have to do is press another button labeled OBOE or FLUTE. And if you want to produce a vibrato, you need go through no finger-wiggling or breath-modulating gyrations; you just press a button labeled VIBRATO.

In fact, just about all you do need to learn is the right sequence for pressing the buttons. And, if you go very slowly at first, it still sounds good, because, unlike a piano, the organ continues to give out tones at full strength as long as you feel like holding the buttons down.

Probably the most interesting thing about an organ is that it has many voices. It isn't restricted to one tone color, like a flute. The keyboards of the Schober theater organ, for example, contain 48 plastic "handles" above the keys. These handles are labeled CELLO, VOX HUMANA, CLARINET, BRASS TRUMPET,

PICCOLO, and so on. Each produces a distinctive voice or tone. How? That's what makes an organ so interesting.

Organ tones fall into groups depending on how they're produced and how they sound. There are four families: flutes, diapasons, reeds, and strings.

A simple sound

The flute family includes all voices which, like the orchestral flute, are bland in tone color, with no sharpness or brilliance. The basic flute voice is produced by a sine-wave oscillator. Since a sine wave has no harmonics, the tone is completely smooth. Several organs use a pure sine wave. The drawback is that only one kind of flute voice is available. A pipe organ, on the other hand, produces many flute sounds, most of which do have some harmonics and thus are not completely bland.

A more versatile way of producing flute voices is to pass complex tones through low-pass filters. An organ may produce from its tone generators a waveform which is essentially sawtooth, as in oscilloscope photo A. (All scope photos were made using a tone generator and filters from the Schober recital organ. Don't be confused because the sawteeth are upside down in relation to the more usual presentation. That happens because the organ uses pnp transistors so that the flyback pulses—which are so fast as to be invisible on the scope—are positive-going.)

It is not enough to deal with one musical pitch; we must see what happens to sounds and waveforms over a wide range of pitches. We shall therefore use five pitches in this article—the first, second, third, fourth, and fifth C's on a standard 5-octave organ keyboard. The frequencies are approximately: 65.4, 130.8, 261.6, 523.5, and 1,047 Hz. We shall refer to them in that order as C₁ through C₅. C₃ is the normal pitch of middle C.

To produce one kind of flute voice, we can pass all five of these tones (and, of course, any other tone that may be keyed during the course of a musical selection) through the single compound low-pass filter of Fig. 1. Oscilloscope photos B, C, and D show the resulting waveforms from three of our sawtooth C tones. (An amplifier stage has been placed between filter output and scope, so the waveforms are inverted with respect to photo A.)

In B, the lowest frequency, filtering has had the least effect. The flyback

pulse is highly visible, meaning that much upper harmonic content has disappeared. The tone sounds far smoother than a sawtooth.

In photo C, which is at middle-C frequency, the slopes are more similar, rounding at the bottom is more pronounced, and the sound is still smoother. And in D, the pitch of C₅, the wave is very close to a sine. These differences in smoothness of sound are normal in pipes and other instruments. The filter of Fig. 1 yields a tone color known as *open flute*, the sound of a flute pipe which is open at the top and contains both odd and even harmonics.

Both pipe and electronic organs can have several kinds of open flutes. They differ principally in how much harmonic content they have, and thus how smooth and "mellow" they sound. Electronically, the differences depend simply on how much low-pass action the filter gives. If the resistors or capacitors of Fig. 1 were smaller, more harmonics would be passed, and *vice versa*.

A different kind of flute tone is produced from pipes whose upper ends are closed or *stopped*. In these stopped flutes, only odd harmonics appear; the evens are missing entirely. Any tone which does not have any even harmonics has a peculiarly hollow or woody sound. The waveform of any tone composed entirely of fundamental and odd harmonics is instantly recognizable because it is symmetrical above and below the base line. A square wave is a typical example—and so, in fact, is a sine wave, which has no even harmonics (because

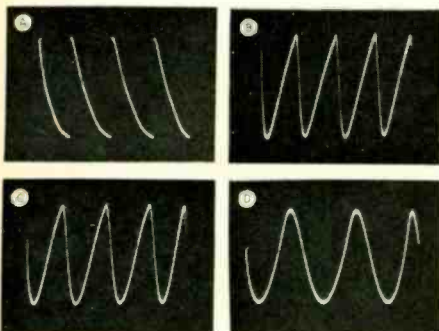

Fig. 1—Open Flute filter is 3-part, low-pass.

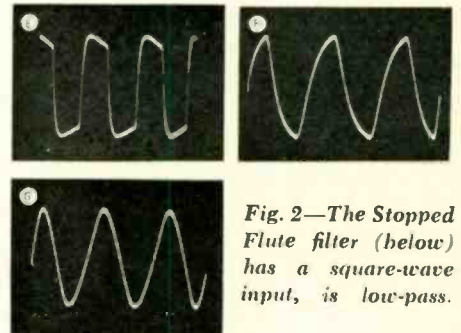
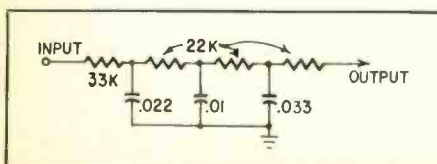
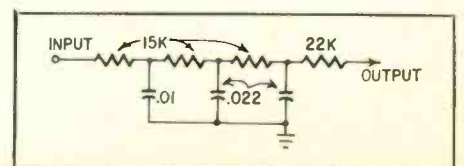

Fig. 2—The Stopped Flute filter (below) has a square-wave input, is low-pass.



it has no harmonics at all). Any waveform that is symmetrical, however complicated its shape, will sound hollow and "hooooooey."

The stopped flutes are produced exactly like the open flutes—with a low-pass filter—except that the source tone is approximately square instead of sawtooth. Fig. 2 shows a flute filter with low-pass action slightly different from that in Fig. 1. If we apply square waves for C_1 , C_3 , and C_5 to the input terminal, the waveforms of photos E, F, and G result at the output. Comparing with photos B, C, and D, you can see that about the same low-pass action has occurred—but in E, F, and G every waveform is symmetrical. The resulting flute tone *seems* more flutey, just because it lacks even harmonics and sounds more hollow.

Diapasons

In a pipe organ, flute tones are produced by pipes which are relatively large in diameter for their length. This relationship of diameter to length can be varied widely, since it is only the length which affects pitch. The larger the diameter, the better the fundamental and lower harmonics. As the diameter becomes smaller and the lip of the pipe across which the air is blown is lowered, the fundamental and lower overtones decrease in power, so that by comparison the sound is more shrill—higher harmonics predominate. That, in fact, is one important way pipe builders produce different sounds.

One pipe-organ sound is completely unimitative of any other instrument. Called the diapason tone, it comes from pipes which are usually of smaller diameter than flutes, with lower lips. They are tailored so that the fundamental is still strong but not so overpowering as in flutes. Thus the upper harmonics are more evident and give a peculiar kind of life and vibrancy to the tone without harshness or shrillness. Diapason tone is known as the backbone of the organ. It is the peculiarly pipelike sound everyone automatically thinks of in connection with church music.

In most electronic organs, diapason tone is produced in just the same way as flute tone—with low-pass filters. The filters are designed to be less effective, however, so that they do not lop off upper harmonics so severely. A refinement in certain organs is the deliberate addition of a certain amount of second harmonic. That is easier than it might seem. The key switching is done in such a way that at least two tones an octave apart are switched by every key and are available separately. The filter is fed mainly by the tone of lower pitch, but some tone an octave higher is added through resistance coupling. Of course, the higher tone is the second harmonic of the lower tone.

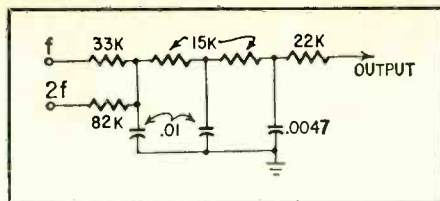

Fig. 3—Diapason filter uses moderate low-pass action on a pair of sawtooth inputs.

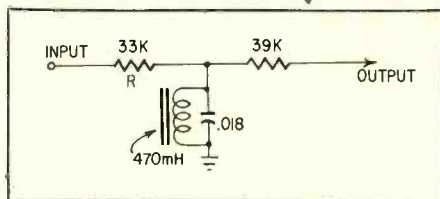
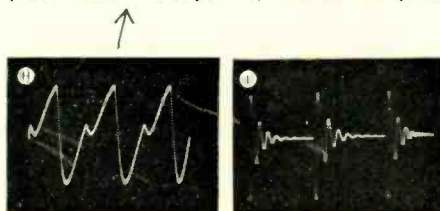

Fig. 4—Tuned circuit acts sharply to accentuate one segment of the tone spectrum.

Fig. 3 is an open diapason filter. The capacitor values are lower than in Figs. 1 and 2, meaning less filtering out of higher harmonics. The main input is frequency f , and that is the apparent pitch of the resulting tone. Frequency $2f$, an octave higher, is added to reinforce the second harmonic. Photo H shows the waveform when f is middle C (our C_3) and C_6 is added through the 82K resistor.

Formant theory

Why does one string, reed, or brass instrument sound different from others? A trumpet, a cornet, and a French horn sound quite different, though the sound is initiated the same in all three. All cellos look about the same, use the same strings, and are played in the same way;

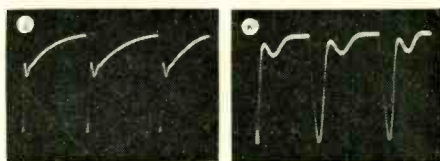
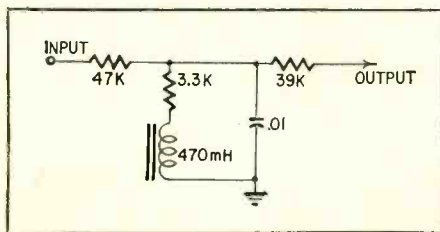

Fig. 5—Resistor softens tone by reducing Q of the resonant circuit. Trumpet sound.



yet any string player will tell you that one cello can have a wide variation in tone color from another. Why? It's due to the formation of sound waves in the instruments.

The filtering action of reed and brass instruments usually includes one part of the spectrum in which response is emphasized. For example, a particular instrument may emphasize all harmonics which fall at and around 1,000 Hz. In that instrument, then, a fundamental tone of B (123.5 Hz) would have an emphasized eighth harmonic, D (147 Hz) an emphasized seventh, E (156 Hz) a strong sixth, G (196 Hz) a prominent fifth, B (247 Hz) an emphasized fourth harmonic, and so on.

→ This spectrum segment over which the instrument produces extra strong output is known as its *formant*. It is almost entirely the formant that determines the characteristic sound of the instrument. The formants of various instruments center on different frequencies, and those formants may be either concentrated or rather diffuse. A strong formant is like a tuned circuit of high Q: the response emphasis is great and is confined to a small bandwidth. A weaker formant represents lower Q; its pass-band is much wider and its peak much lower.

Any of these spectrum characteristics of an instrument can be provided just as well by an electrical filter. The oboe filter of Fig. 4 is a good example. Resistor R and the tuned circuit form a voltage divider across the input sawtooth signal source. The impedance of R remains the same at all frequencies, but that of the LC combination has a pronounced peak at about 1,600 Hz. The Q of an inductor suitable for this purpose is fairly high, so the resonant rise is steep and the emphasis band narrow. If you can hear in your mind the sharp, whining sound of the oboe, you will not be surprised that a filter like this can reproduce it.

Photo I shows the oboe waveform at middle C (C_3). The oboe is what I would call an "extreme" reed, with a very sharp formant—so much so that in addition to its bandpass action the LC circuit actually "rings" in response to the sawtooth pulses and produces the damped wave train of photo I. The amount of ringing depends on the Q of the inductor. If the inductor has too high a Q, the tone can be quite harsh; a shunt or series resistor will soften the oboe voice.

The trumpet filter of Fig. 5 does use a resistor to lower the tuned-circuit Q. It is in series with the inductor. The sound of the trumpet tone that results is much freer, not at all nasal or buzzy, and has plenty of fundamental coming through. Photo J shows the trumpet waveform at C_3 , and photo K shows the

Special Sounds of Organ Music

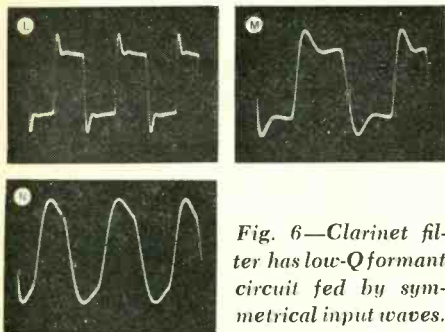
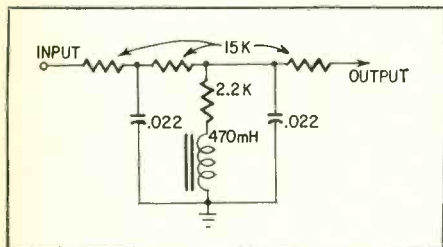

Fig. 6—Clarinet filter has low-Q formant circuit fed by symmetrical input waves.



output of the same filter two octaves higher at C_5 .

The clarinet is a reed instrument with hollow and woody tone. To reproduce its sound, we start with square waves. They sound hollow, you will recall, because they are lacking in even harmonics. The clarinet filter of Fig. 6 has a tuned circuit with about the same resonant frequency as that of the oboe filter in Fig. 4—but the sound is as different as night is from day, because the difference between filtered square tones and sawtooth tones is so great to the ear. Of course, other elements accentuate this difference. The Q is reduced by the 2,200-ohm resistor, and the low-pass section at the input removes the buzz which would be caused by higher harmonics, helping to achieve the smooth, mellow effect of the clarinet. Photo L shows the clarinet waveform at C_3 , and photos M and N show waveforms for C_4 and C_5 .

String voices

The so-called string voices of a pipe organ are made by pipes that are narrow with respect to their length. Fundamentals and lower harmonics are suppressed, making the upper harmonics stand out. None, however, are very good imitations of orchestral string instruments.

→ In an electronic organ, shaping spectrum response is so easy that imitations of string tones are possible. Unfortunately, only steady-state tone can be imitated easily. The transient effect of an actual string instrument—bowing sounds, variations in vibrato, and the like—are such an important part of our impression of violin, viola, and cello

that even an electronic imitation is never convincing.

The basic and most brilliant string voice is created by a simple high-pass filter, a small capacitor between a source of sawtooth tone and the load. That transforms the sawtooth into a sharp pulse (photo O) which simulates (actually exaggerates) the pulse-type excitation of a string by the rough hairs of a bow. The sound thus generated is so buzzy it is not very useful musically.

From the organ designer's standpoint, the string-instrument body is pretty much another formant producer. Obviously it does not allow all harmonics generated by the strings to be heard equally; it shapes the spectrum, much as does an oboe body, but infinitely more broadly. String stops for an organ can therefore be designed as formant filters. But, instead of using LC circuits to achieve narrow peaks in response, low-pass and high-pass RC filters are combined to give more gradual transition from one part of the spectrum to another.

Fig. 7, a diagram of a cello filter, is an example of this combination of effects. The series .022- μ F capacitor and 47K resistor yield the high-pass action. The 0.1- μ F capacitor in series with the 1,800-ohm resistor to ground boosts low frequencies to produce the full tone of the cello. Above 800 Hz, the capacitor becomes a short circuit and there is simply 1,800 ohms to ground. Below that frequency, the impedance becomes larger and larger, so that response rises. The small .0047- μ F capacitor begins its

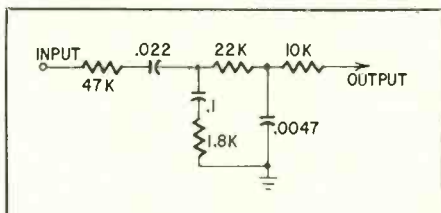
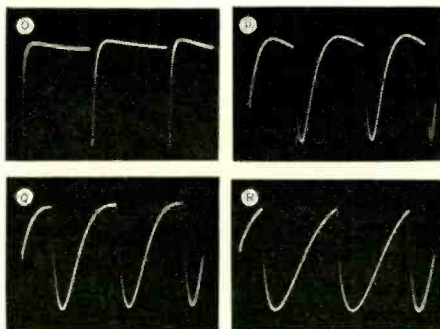

Fig. 7—High-pass and low-pass filter shapes response with bandpass characteristic and produces cello-sounding tones.

effect about 3,000 Hz; it is there simply to eliminate unwanted buzziness. The one network therefore passes highs, boosts bass, and attenuates ultra-treble. The result is a shaped spectrum response which delivers a cello-like tone.

Cello-filter waveforms confirm its effectiveness. Photo P is at C_1 . The original sawtooth has become more pulselike as its top is flattened out. There is still plenty of high harmonic content, as you can see from the almost invisible start of the flyback. But the bottoms are rounded off and the flyback is not quite invisible, indicating that top harmonics have actually been cut down some.

Photo Q is an octave higher, at C_2 . Since the fundamental is higher, the high-pass section has less effect. And in photo R, another octave higher, high-pass action is practically gone: the sawtooth ascenders are about at their original slope. Ultra-highs are still cut off, however—more so than before. Listening to the output of this filter with a variable-frequency source gives your ear the idea that the tone quality is identical throughout the range, even though the waveform and actual harmonic makeup change.

Designing organ stops

If what I have said suggests that voicing an organ is simple in terms of circuitry, you are right. It is so simple, in fact, that the largest Schober organ has little plug-in printed circuits for the voicing filters, and a kit allows the organ owner to design extra voices.

What is not so simple is deciding what voices should be on an organ and just what they should sound like. Thousands of sounds have been used at one time or other, and hundreds are used commonly. The question of which should be on a particular organ model can be decided only by experience, taste, and objectives.

It is not enough that certain voices sound good or authentic. The designer must first provide as many voices as costs allow that are useful for the most kinds of music. The voices he chooses must also combine well for a large variety of effects. And, unless the organ is strictly for an old ladies' home where anything not completely soothing might give someone a heart attack, he must design reed and string voices which are sharp, loud, and blatant, in addition to flutes and diapasons which are more basic and have more foundation tone.

Above all, his selection of voices must include enormous differences. If most of the voices of an organ sound about the same, the whole purpose of this exciting palette of tone colors known as the organ will have been defeated.

END

FIVE IN ONE: America's Most Unusual Service Shop

Energetic . . . different . . . unusual. These terms describe a new and interesting approach to shop management **By WARREN SMITH**

ONE OF THE NATION'S MOST PROGRESSIVE television and electronics servicing organizations is located in the unlikely town of Marshalltown, Iowa—a sleepy community of 25,000 population. Subject of considerable interest throughout the service industry, AC Television & Electronics Clinic operates with a cooperative management.

"We have five individual shops working within the framework of the clinic," declared founder and creator James Yordy during an interview. "Actually, if you count the clinic, we have six service firms under our roof."

"The clinic is a corporation," explained Yordy. "Stock is held by the five shop owners who work out of the clinic. The clinic provides an office, service space, utilities and a sales department; it's also a wholesaler for parts and tubes. An office girl and a bookkeeper are employed by the clinic as well."

Despite the advantages of a clinic operation, individual service technicians

in the corporation retain their own distinctive shop names. Current service-tech stockholders include:

Ervin Van Horn—Bud's TV
Wilbur Hatcher—Hatcher's TV
James Yordy—Video Center
Lawrence Turner—Turner TV
Howard Bonar—Howard's TV & Electronics

To understand fully the operation of the clinic, let's start at the beginning. A few short years ago, James Yordy and the others owned separate shops.

"We faced dour prospects because of high overhead," Yordy explained, "and I had the idea of getting a bunch of the fellows together with a tube inventory; the mother shop would provide wholesale service to the service techs. I figured we could work together with a single sales department and slash overhead costs with a group operation."

Yordy had run the gamut of shop sizes. "I started in business with a partnership shop and eventually grew to five

men, needing more help all the time. Then I went back to a single proprietorship and could see the efficiency of a large shop," he recalled.

AC Television & Electronics was incorporated by Yordy and Larry Turner in 1961 with a \$25,000 stock offering at \$10 per share. They started with a \$6,800 wholesale-valued inventory; Yordy borrowed money for operating capital.

As each new member entered the firm, his tube-and-parts inventory was exchanged for clinic stock; he also purchased additional stock. Each newcomer has an option to obtain stock holdings equal to those of the older members.

"In fact, the three earliest members now have been frozen in stock purchases while the other two catch up," said Turner. "We want to maintain this as a group operation. We don't want one person to benefit more than the others."

The five shops in the clinic remain individual shops in every sense of the term. "We do our own servicing, and each shop has its own set of books," said Bud Van Horn. "Broadly defined, we do our own billing, but making out the statements can be handled by the clinic if we wish." Each shop supplies its own equipment. The clinic acts as a wholesaler to the shops within its walls.

When a new shop enters the organization, the clinic supplies a fully stocked tube cabinet on consignment. As parts and supplies are sold from this initial inventory, the clinic bills the shop owner for replacements. (The men use a three-part ticket: a copy each for customer, service technician and the clinic.)

Parts and tubes are billed to the shops at 80% of list. The clinic also charges 25¢ for every service call and has a fee of 20% for every shop job.

"The man who does the most work is paying the greatest overhead," said newcomer Howard Bonar. "He also utilizes more room, services and expenses." Bonar is vice president of the West Central NEA (National Electronic Associations), and Yordy is a director of the same service group.

Each individual shop sets its own prices, and the clinic has an established flat-rate price book. In addition, shop owners keep records of "labor trading."

"I had a sound-system job recently and could finish it quicker using Bill and Howard," said Yordy. "At the end of the month they'll bill me for their time. Of course, I also bill them for any work I've done for them."

Work for the clinic—warranty and service calls, for example—also is billed out each month on an 80-20% split. Any sales made by individual shop owners are handled by billing the com-



The five partners who own and operate AC Television and Electronics Clinic.

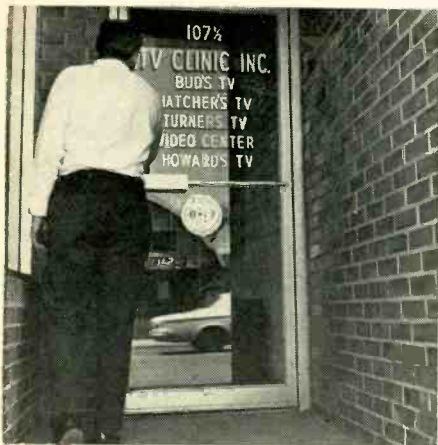

By sharing facilities with each other, the five shops cut overhead in business.

Rear parking saves time in getting the receivers from the cars to the bench.



America's Most Unusual Service Shop

mission to the clinic.

"Service calls to the clinic are given to the man without work," said Bill Hatcher. "We all share them."

"We don't have a frantic scramble for calls either, because everyone is busy," added Yordy.

Clinic profits are distributed:

1. Through dividends on stock.

2. The remainder is refunded as an additional discount, based on the dollar volume of each individual shop.

The clinic provides an insurance program for the shop members. A life-insurance policy is carried on each man, payable to the clinic. "In the event of a death, the other members can buy out the widow," said Yordy.

Retirement insurance also is carried on each man. "It's a life-insurance policy that turns into retirement at a specific date," said Bonar.

"We have weekly meetings to thrash out business problems," said Bud Van Horn. Since the color-TV boom, disbursements from clinic sales have skyrocketed.

"But, we'll always be primarily a service organization," Turner stressed.

Friday-night meetings are attended by all shop owners. "We go into a discussion with the idea there are no 'winners' or 'losers.' We just want to come up with the right solution to a problem," is how Yordy put it. "If our problems are few, we concentrate on long- and short-range planning."

"We make an effort to attend every service meeting and whatever management schools we can fit in," said Hatcher.

"We have four of our shop owners in the Dale Carnegie course now, and the other is joining the next class," put in Yordy. "We also are active in TSA-

Iowa and NEA."

Financing for the group is less of a problem than for individual shop owners. "Bankers prefer to do business with corporations," Yordy pointed out. "Our line of credit is much larger and more convenient than five separate shops could swing."

"Financing a corporation is no problem either, once you're rolling," said Turner. The clinic carries its own paper on merchandise sold, borrowing from the bank to fund credit sales.

"We do business with one bank, and a competing banker actually stopped a couple of the boys on the street one afternoon and said, 'We have money, too, fellows!'" noted Yordy.

In advertising, each shop has its own yellow-page ad, as does the clinic. "We remain very flexible on advertising, and each man builds his own shop image," said Bonar.

Bonar previously was in business in Storm Lake, Iowa. Hearing of the clinic

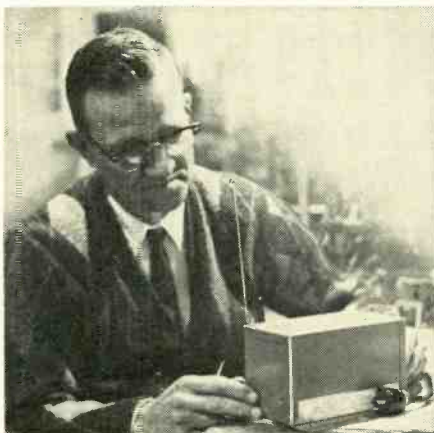

Founder and ideaman for the TV clinic, James Yordy checks out an amplifier.

idea, he moved to Marshalltown to join the group. "I haven't had a phone bill or advertising costs, yet this has been my most productive year," he enthused. "The biggest asset is having broken the habit of being in a rut."

"Clinic services save plenty of time and effort, too," Bonar went on. "For example, the clinic subscribes to a credit reporting service; we use it before making a service call, and it's great."

What's in the future for this strong group effort?"

"We need refinements in shop and service areas to increase efficiency. We need a more efficient shop layout," explains James Yordy.

"We also can use additional members. With proper controls and the right type of men, there is no limit to the number of shops we could coordinate under a single roof."

"We're always getting new ideas and trying them out," said Hatcher. "There is constant expansion and growth. We're always adding new merchandise lines and refining our service methods, and adding new service equipment, too."

"The future is unlimited," declares Yordy. "The future always belongs to those who prepare for it."

Yordy's original idea for shops within shops has created an energetic, fast-growing organization simply bursting with financial health.

"Now I'd like to see a regular service center—like a shopping center," says Yordy. "It could be composed of service firms ranging from air conditioning to electronics to washing machines. It would provide space, facilities and lower overhead for a variety of service people."

James Yordy—a man who turns his dreams into reality—isn't one to limit the dimensions of his future. **END**

First Consumer Electronics Show

Plans for new week-long exhibit of home-entertainment equipment

THE WEEK OF JUNE 25 THROUGH 29 will be a busy one for the electronics industry. A week earlier, the annual NEW (National Electronics Week) show in Chicago will keep manufacturers of small electronic parts and components occupied showing their wares to distributors from all over the country.

Fresh (or not so fresh) from that mammoth task, the industry will move to New York into the Americana and New York Hilton hotels for the Consumer Electronics Show—the first national exhibition especially for home-entertainment electronics.

In recent years, home-entertainment manufacturers have shown electronic devices at a show in Chicago sponsored by the National Association of Music Merchants (NAMM), mainly because there was no show specifically for home-entertainment electronics. This year's new show has been put together by the Consumer Products Division of the Electronic Industries Association (EIA). It runs in New York the same week the NAMM Show runs in Chicago.

Exhibitors had to choose between the two or face the expense of two simultaneous shows. A very few found it necessary to make both; an overwhelming number who had no stake whatever in music as such decided to show only in the Consumer Electronics Show in New York.

We talked to Jack Wayman, staff vice president of the Consumer Products Division of EIA, who is responsible for getting the Show "on the road." He explained some of the Show plans to us recently.

The Consumer Electronics Show

(CES) will be part of Consumer Electronics Week—June 23–28, 1967. The National Appliance and Radio-TV Dealers Association (NARDA) will hold its annual convention the same week. The NARDA convention starts Friday, June 23, and finishes Sunday, June 25, the first day the CES exhibits will be open.

The first day will feature an all-industry reception and banquet in the Grand Ballroom of the Waldorf-Astoria. After that, it's down to business. In addition to the exhibits, which open at noon Sunday, the remaining three days will feature three morning seminars (8:30–10:30 am) planned to build profits for all the dealers who attend them. They should be full of helpful ideas.

Monday—Government and industry symposium

Tuesday—Audio and video tape equipment and merchandising

Wednesday—Hi-fi components and merchandising

We sent letters to the companies who signed up early for the Show. From those who responded we got a fairly accurate picture of what will occur at the exhibit halls in June.

We asked first their reasons for choosing this Show. Most repeated were: "It's the only major show devoted to home-entertainment equipment" and "It's a limited show, not open to the public but to dealers only." Other reasons given: "Wide acceptance among other manufacturers"; "Because it will attract East Coast buyers for big chains"; "Best way to reach a large number of poten-

tial dealers and distributors."

Whatever the reasons, the Consumer Electronics Show promises to be a success. About 100 exhibitors attest to the popularity; in fact, the space was sold out long before the deadline. Practically every kind of home-entertainment device will be shown. Considering the name Consumer Electronics Show, we expected a lot of other kinds of equipment: garage-door openers, burglar alarms, and even solid-state appliances. Not so. The CES will be devoted only to home-entertainment electronics.

The list of exhibitors is extensive, but it's on page 83 so you'll know who you can visit at the Show.

We asked exhibitors what products they'd be displaying. Here are some they told us will be there for dealers, distributors and buyers to see:

- Color television sets
- Portable TV's (color and b-w)
- Hi-fi and stereo components
- Console hi-fi centers
- Table and portable AM radios
- Auto radios
- FM radios of all kinds
- CB walkie-talkies (Part 15 types)
- Record players and changers
- Tape recorders
- Cartridge-tape machines
- Video tape recorders
- Shortwave receivers
- Electronic organs

Many of the items will be new to the lines of the manufacturers. From all appearances, the chief aim of most exhibitors is to find additional outlets. Distributors, dealers and retailers will all be there. Many exhibitors are counting on the attendance of buyers from large department store and discount chains—the door, often, to multiple sales that can spell quick success for a new line.

As mentioned, the public won't be admitted. One reason was summed up by an exhibitor in this way, "For the first time we have a show of our own, one in which we have time to see the people who really can sell our goods. When we were at the Music Show (NAMM) there was not enough time for the people directly concerned with our segment of the home-entertainment field. Exhibitors will have more time to spend with people who are buyers, not lookers." END

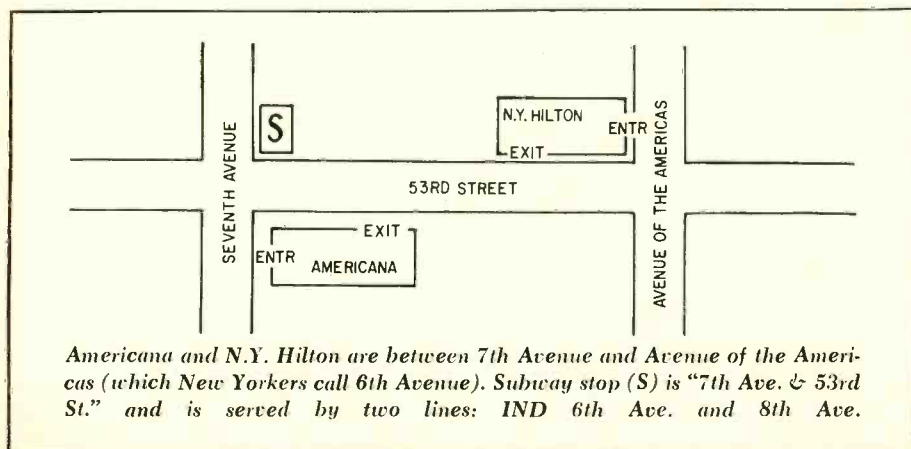

The Solid-State Camera is Here!

By RAY CLIFTON

ONCE UPON A TIME, WHEN YOU WANTED to take a picture of the family on a picnic, it was easy to goof. The problem has always been the same: The light-sensitive film must be exposed to the scene in a certain way—you have to open the shutter and let in just *so much* light for just *so long*. Too much light, and the picture's washed out; too little, and it's too dark to see anything.

Not many years ago, the semiconductor revolution invaded camera territory. The solid-state photocell (or photoresistor) became the "electric eye" used to control the amount of light allowed to expose the film.*

Until recently, all cameras used a mechanical shutter, operated by cocking a spring and releasing it. In time the spring metal became fatigued and the

tension changed. Furthermore, temperature and moisture affected spring tension. All these factors caused a change in shutter speed. On a cold day, for instance, you'd shoot at what you thought was 1/120 second. But the stiff mechanical shutter might stay open for as much as 1/90 second. That's a 25% increase in exposure, and your picture would be too light.

There was one other defect in the mechanical shutter. The speed was adjustable only to certain fixed points—1/25, 1/50, 1/100 second, etc. You couldn't shoot at 1/83, for example, although that might be the best possible speed for a particular scene. Nit picking? Maybe—but some ingenious nit-pickers have devised a neat way of assuring just the precise exposure.

The *electronic shutter* overcomes the difficulties of a mechanical assembly. The shutter is opened and closed by electromagnets or solenoids. A photo-

cell determines the amount of light and controls the charging of a capacitor. The capacitor charge biases a transistor circuit which controls the electromagnet. Simple? Sure—and capable, too.

Because the photocell is continuously responsive to light intensity, the shutter speed is continuously variable from one end of its range to the other. This means you get precise speeds, and the amount of light and duration of exposure are always exactly what you need. Even if the light intensity changes while the shutter's open, the circuit compensates for this change. Since the photocell is sensitive to extremely low light levels, an electronic camera can take pictures automatically even at night.

Polaroid

This company was first to bring out an electronic shutter—in 1963. Now used on the current models 250 and 100 Land cameras, the shutter is partly mechanical and partly electronic. The circuit is diagrammed in Fig. 1 and mechanical action is shown in Fig. 2. When you depress the cocking lever (not shown), two shutter blades are armed by stretching two springs. When the tripping switch is pressed, the two blades are released. One—the opening blade—moves and opens the lens. The other—the closing blade—does *not* move; it's restrained by the electromagnet activated by Q2.

Timing switch S2 is closed by the cocking lever, thus shorting the capacitor bank. The tripping switch opens S2, allowing the capacitors to charge through the photocell. The capacitors charge at a rate determined by the amount of light passing through the lens and striking the photocell. When the voltage on the capacitor bank reaches the forward-bias point of Q1, it conducts, biasing off Q2 and causing the electromagnet to de-energize. This action releases the closing blade, which snaps back and closes the shutter.

Seiko

This shutter is used on the Minolta Electro Shot, the Olympus 35-LE, the Ricoh Super Shot, and Canon cameras. The circuit (Fig. 3) consists of two sections. One section operates an underexposure warning light, while the other operates the shutter blades.

When the shutter release switch is depressed only a short distance, it first switches the photocell into the warning circuit (Q4-Q5) by means of S1. This occurs before the shutter is opened. If there isn't enough light on the scene, the resistance of the photocell is high and the voltage drop across it biases Q4-Q5 on, lighting the warning lamp.

If there is enough light, however, depressing the shutter release throws S2

* "Cameras That Think," RADIO-ELECTRONICS, January 1963, p. 24.

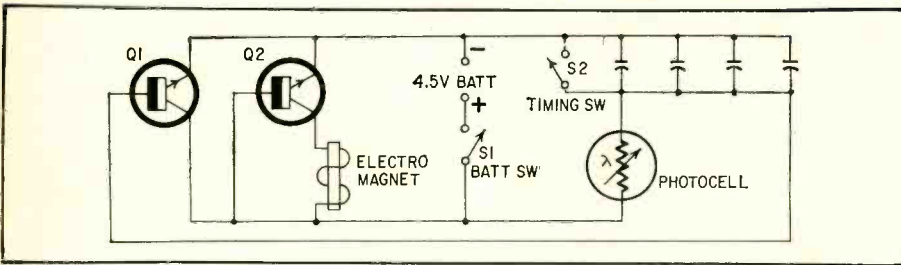

Fig. 1—A simple circuit in the Polaroid Automatic 100 camera operates the shutter.

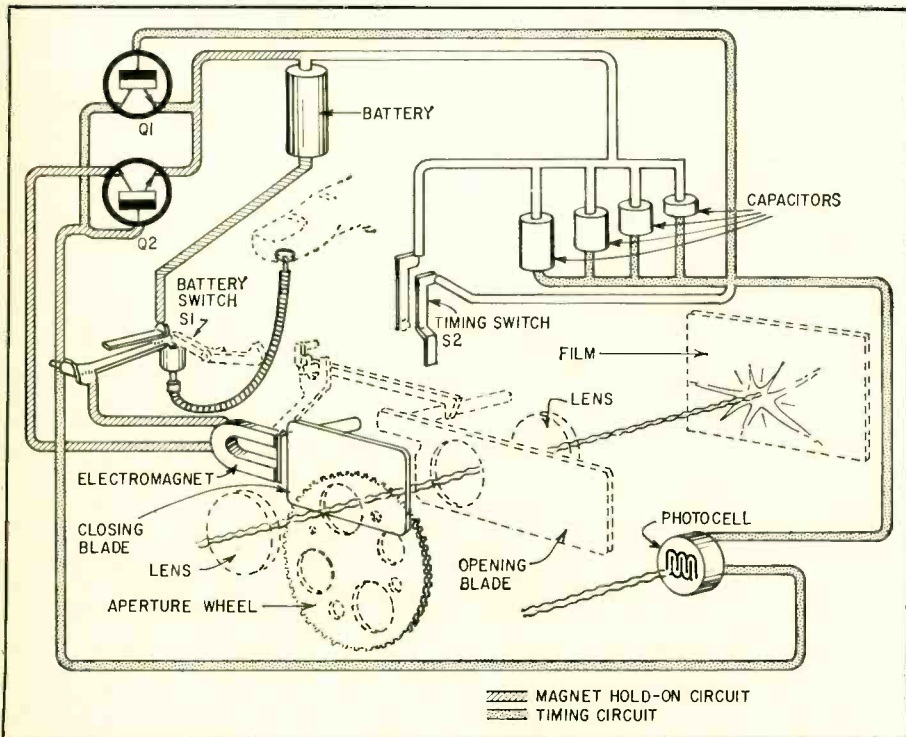

Fig. 2—Mechanical function in Polaroid camera is typical of modern solid-state shutters.

to the timing position. Capacitor C begins to charge from the battery through the photocell. The amount of light determines the rate of charge of C.

Meanwhile, S3 closes and triggers solenoid SLD1, opening the shutter and latching S3 closed. When the charge on C reaches a certain point, it biases Q1-Q2 on, which turns on Q3. Finally, Q3 activates the shutter-closing solenoid SLD2, and the shutter is closed.

The photocell is not used for flashbulb shots. A flash switch substitutes variable resistor R1, which is adjusted to match the exposure guide number for the particular flashbulb and film.

S4 is a battery-test switch that lights a lamp if battery voltage is sufficient.

The Seiko shutter circuit is completely automatic and may not be manually overridden. Exposures can be varied continuously from 1/15 second at f/1.8 to 1/500 second at f/16. However, the only manual control on the camera is a film-speed setting in ASA numbers, from 25 to 400.

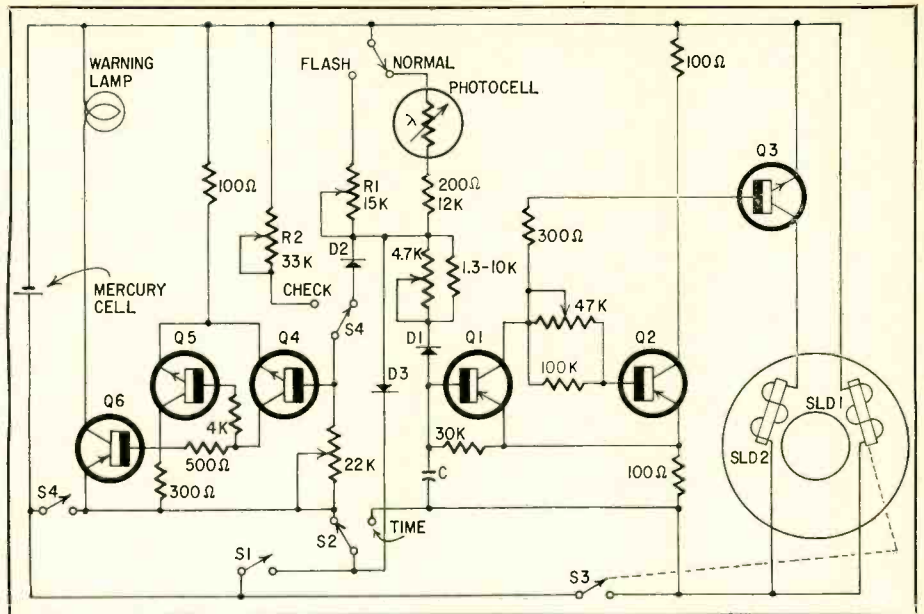

Fig. 3—The Seiko electronic shutter circuit employs an underexposure warning lamp.

Copal

This company makes two shutters; the first is used on the Olympus Pen-EM and Yashica Electro Half cameras. The second unit is used on the Yashica Electro 35. Copal I uses a four-transistor circuit in which the first three stages are normally biased off. When the shutter button is depressed, the fourth transistor is biased on, activating a solenoid that opens the shutter blade and holds it open against a spring. As in the preceding examples, the photocell charges a capacitor that eventually biases the first transistor on. The second and third stages are direct-coupled and also turn on. They turn the fourth stage off, releasing the shutter blade, which closes.

Copal I allows manual control of the aperture. You can set the shutter opening at the value desired—save for greater depth of field—and the circuit will then determine the corresponding length of time the shutter will be open, depending on light intensity. There are three signal lights atop the camera. A red lamp indicates too much light, and a yellow lamp too little light, for proper exposure. The third lamp (green) is used for battery-voltage checking.

Copal II has the preceding features but is a bit more sophisticated and uses five transistors. The circuit is shown in Fig. 4. Operation is very similar to Copal I. There is, however, one outstanding addition: The user may manually control either aperture or shutter speed. If you want to shoot at 1/100 second, you can preset the shutter, and the circuit will then open the aperture wide enough for a proper exposure. Conversely, if you want to shoot at f/16, the circuit will determine the speed.

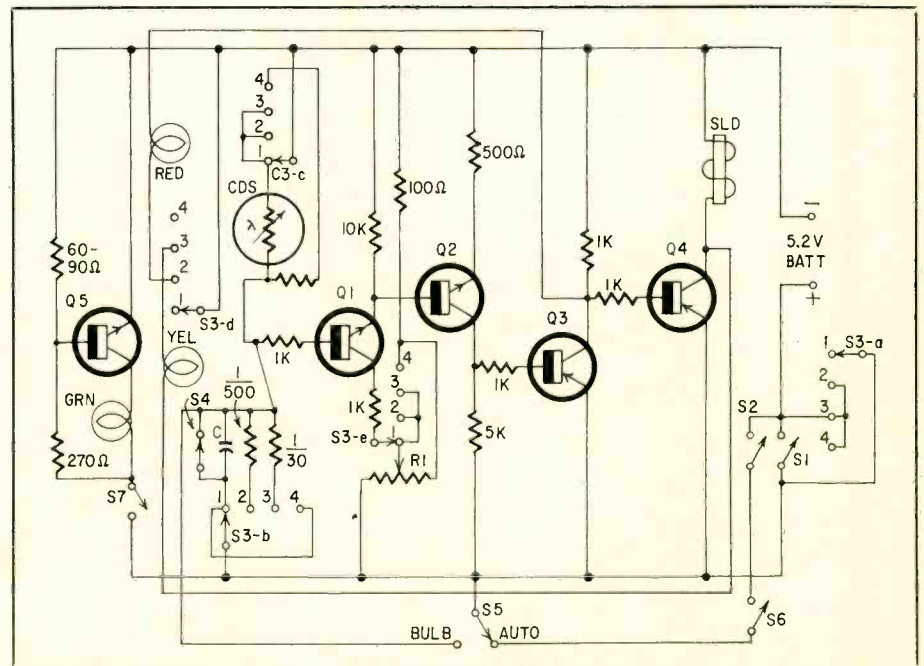

Fig. 4—Copal II solid-state shutter allows manual control of aperture or shutter speed.

In the automatic mode, when shutter release S1 is depressed, Q4 conducts and pulls the spring-loaded shutter open with the solenoid. Meanwhile capacitor C charges through the photocell, establishing a bias on Q1. When the voltage on C reaches a certain level, it biases Q1, Q2, and Q3 on. This action turns off Q4, releasing the shutter, which closes.

S3 is used to select shutter function. At position 1, you can have either automatic operation or bulb (time exposure), selected by S5. Positions 2 and 3 switch the red and yellow warning lamps into the circuit, to check for under- or overexposure. Position 4 is used for flash operation, with a fixed shutter

speed of 1/30 sec.

S4 is an override switch to bypass automatic operation, and S7 is the battery-test switch. R1 is the manual shutter-speed control.

What's left to be modernized in the camera? Well, there's a good possibility that you'll soon be able to buy a camera with automatic focus. Canon has been working on a prototype model for several years and now reports the system works satisfactorily 80% of the time. See—all you have to do now with a camera is aim and press the button. Press the button? Now there's an idea—an IC that automatically pushes the button for you! Hmmm. END

Radio-Electronics Interviews Consumers Union

Revealing facts about recent "exposés" of TV-service cheating

By **FOREST H. BELT**

Caveat emptor . . . let the buyer beware. That was the way it was phrased a few years ago. Now the chant is: Protect the consumer. Save him from fraud. With credit tight, everyone wants the most for his money. The cause of protecting the consumer is strong medicine.

Consumer protection through education is the avowed purpose of a non-profit organization located just north of New York City, a controversial outfit called Consumers Union. The organization was formed in February 1936, a dissenting splinter off an older organization, Consumers' Research, that was founded in 1929. Through its monthly publication Consumer Reports, CU tells its opinion of almost every imaginable consumer product.

Here at RADIO-ELECTRONICS, we've always read the reports on electronic devices, particularly those on hi-fi gear, to see how close CU findings come to our own. For this special issue on Consumer Electronics, we think you will be interested in just what goes on inside the CU complex at Mount Vernon, N.Y.

Consumers Union agreed to a tour and interview, and I settled on three things that would interest readers of RADIO-ELECTRONICS. The first is the instruments used there. The second is the tests performed on home-entertainment equipment. The third relates to an article which purports to expose fraud in the TV repair business, relying on rigging sets and calling unsuspecting service technicians to fix them.

But let's not get ahead of the story.

My tour was conducted by Karl H. Nagel, head of the electronics division of Consumers Union. I saw a soundproof listening room where panels of listeners sit and listen to speakers, or tuners, or amplifiers, or preamps, or turntables—whatever is being tested for subjective quality. The units are unidentified and not even visible to the audience, who can report only what they actually think of what they hear.

Nearby, I visited their anechoic chamber, where mikes, hearing aids and speakers can be tested without the influ-

ence of room acoustics. A custom-built control room contains some exotic recording, playback and measuring equipment. Chart recorders, specially redesigned tape machines, fancy turntables, and banks of jack fields make it easy to test almost any kind of sound-reproducing equipment. For special tests, CU engineers have developed their own test tapes and recordings when none was available commercially.

Ingenuity was evident in the laboratories. Limitations in commercial equipment are circumvented by unusual gear for special purposes. CU-built instruments for automatically measuring wow and flutter are an example.

In the radio and TV testing sections, a complete television transmitter and monitors for both b-w and color, a Faraday screen room for dependable rf measurements, FM generators, and a fine array of lab test equipment were in use. I have to admit, after talking with the test engineers and seeing the facilities, I came away convinced that the men at CU have a pretty good idea of what they're doing—certainly in the electronics division.

After the tour, I settled down for the interview with Mr. Nagel and with Mr. Monte Florman, associate technical director. They started by telling me more about the organization.

RADIO-ELECTRONICS: A general question: how and why did Consumers Union come into being?

CONSUMERS UNION: Well, that was quite a while ago. A number of people were interested in the meaning of advertisements. A man named Arthur Kallet had written a book called "100,000,000 Guinea Pigs," and he had worked for quite a while trying to find the real value of advertising. He and a few followers started a very small mimeographed newsletter that was sent only to members of a club—a hundred or so.

Kallet started to employ some technicians, consultants, and a few people in universities and institutes to get the answers. The information he got was very crude in the beginning. But it was factual

and he informed his members of the results. This grew and grew so much that after a while he had to hire more people and get enlarged quarters, and then the magazine *Consumer Reports* came into being. It had relatively few pages but, as far back as 25 years ago, it was already a newsstand type of thing.

R-E: Has CU always been here in Mount Vernon?

CU: No, it was originally in New York. The technical department had offices on Union Square. Some things were (and still are) farmed out for testing. The editorial and subscription departments were downtown.

After some time, they bought this building in Mount Vernon to get everything under one roof.

This move was very successful. We had more contact with the editorial department and they with us. Now everyone works more closely together. The technical department—that's us—finds the facts and the editorial department makes the interpretations in the magazine.

R-E: You have a pretty large organization. How many people?

CU: We have over 200 now. That includes the subscription department which is a very large section of this organization. Don't forget, the magazine has a circulation over one million, now.

There is of course an accounting department. And a very important marketing and purchasing department. We have to know what to test. So, the marketing department is always getting the latest market information—what items are in demand, what people buy and how many. Then they know what to purchase for us to test.

Also, they are responsible for the final check when we go to print. Prices are important, so they are in constant touch with the manufacturers' merchandising and sales departments to get the price info directly from the horse's mouth.

R-E: What about after you're in print? I understand things can get pretty warm, then.

CU: Yes, we might have contact with manufacturers after we have published our articles. Quite often, I would say—

we get a variety of questions.

We are open to questions, and we keep the test samples for several months. If a manufacturer wants to know what we did with his product, he can come over. We welcome the opportunity to review test results with him. It is time-consuming, but cannot be helped. They usually agree with our findings. I'd say they go home convinced we operate honestly and competently.

R-E: What kinds of electronic gear do you test? You've shown me color TV, hi-fi tuners and amplifiers, portable TV's, and you have some record changers on time-test back there. What else?

CU: Don't forget good old radio. Millions still listen to it. We test all kinds—FM, AM, portables. Anything that is audio.

R-E: Tape recorders?

CU: Oh, sure. And anything that is television . . . antennas, accessories.

R-E: Do you check lead-ins?

CU: We intend to. We haven't done it for a long time. You see, we send out questionnaires to our readers asking them what they would like for us to test. We get some very good ideas from them. But not many are interested in lead-in wires, so we will do it but maybe not soon.

R-E: What are they most interested in?

CU: We would like to bring out a high-fidelity system report again. We have tested loudspeakers of medium and low price. We have tested stereo cartridges, single-play turntables and automatic changers, and we are now testing stereo receivers. It is only logical that we report on complete systems. Then the reader can maybe get our magazine and go out and select a system.

Doing hi-fi reports is difficult because of market timing. Most audio products come out in October. Finding the units, getting them tested, preparing everything for publication, and then coming out in print before the things are obsolete is not always easy. But we're trying very hard to do what we can to overcome that.

R-E: You buy all your units for testing, don't you?

CU: It is the most important policy of our company never to accept anything from a manufacturer, regardless of what it is. We send out shoppers (the market department again). They do not reveal our name. They use their own names and pay cash, put the merchandise in their own cars or station wagons and take it with them. No one at the store knows where it goes—and that it is going to our laboratory to be tested.

R-E: What kind of stores do they shop in?

CU: The same as you or anybody else would. You like to get what you want for the least money. So, if you have access to discount stores and can find what you want, you buy it. So do our shop-

pers. If they cannot find it, they might go to other stores where the price may be higher.

R-E: When you buy at a discount price, do you print that price or do you print the manufacturer's suggested retail price?

CU: We print the suggested retail or the official list price. In the case of mail-order houses, we print the mail-order price plus shipping. We often mention, though, when discounts may be available. If the project warrants it, we would go out and make a special survey of the price situation.

For example, we might test refrigerators, and then write to our shoppers in cities throughout the US and have them go out and make a complete price survey. This way we give our readers a range of prices, sometimes lower and sometimes higher than list.

So that's how the organization conducts its business of protecting the consumer from poor bargains. Manufacturers have grown to respect (and even dislike) this company that prints the facts as it sees them, fearlessly and impartially. A good rating in a Consumer Reports article can spell almost instant success for an unknown product or company, while poor ratings have been accused of dooming some widely advertised products of giant companies.

But we were anxious to ask how this impartial organization, with all its technical competence, viewed the present efforts from many directions to save the consumer from fraudulent practices in the home-entertainment servicing business.

The servicing industry has been given black eye after black eye by presumably well-meaning guardians who "gim-

mick" supposedly normal TV sets to entrap technicians in shady practices. This form of "protection" seems limited to TV technicians, for I've not heard of anyone doing it to hi-fi, radar, or communications or industrial technicians. The major fears of consumers, or of their guardians, seem to lie in the realm of TV repair or servicing.

The attorney general of Illinois tried it on a number of technicians last year, more than 20—all of whom had been the subject of numerous complaints by customers. Most of them did try gyping the "test" customers, but only three were convicted of outright fraud. The resulting news items did not make much of the fact that the entire twenty-odd were prior offenders and were not a sampling of the service shops in Chicago. News reports implied that the incidence of fraud in this group was typical of the industry, and were thus grossly misleading to the public.

Late last year, educational TV stations around the country carried a film purportedly telling viewers how to get their "money's worth" in TV servicing. Produced by National Educational Television, Inc. (NET), the film contained several technical inaccuracies. Furthermore, the few save-money hints that were offered were the type likely to get would-be do-it-yourselfers in trouble.

That NET film epitomized the unfairness of gimmicked-set testing, especially when it is administered by people who are technically unknowledgeable. Again, the published results were misleading to the general public.

Early this year, WCBS-TV News in New York aired a news film about a test in which Consumers Union was a participant. The method was, as usual, the

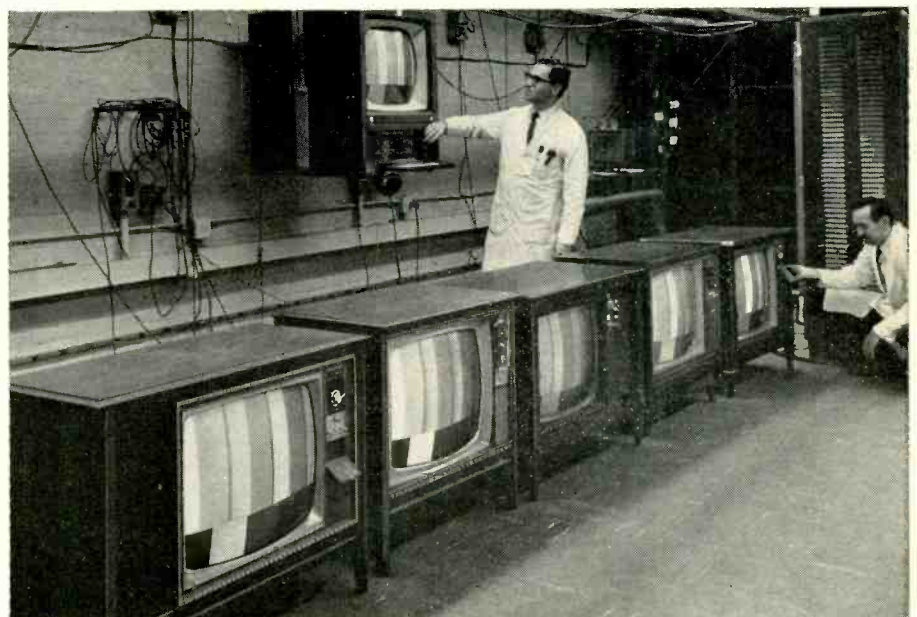

In this CU test lab, cabinet at right houses a color-TV transmitter. Home receivers in foreground are compared in performance with that of wall-mounted master monitor.

Radio-Electronics Interviews Consumers Union

gimmicked set. The results were also published in February Consumer Reports. We talked about these shows and tests.

R-E: Late last year, there was an article in *Consumer Reports* in which you compared the amount of service needed by different brands of TV. National Educational Television used some of the figures in one of their "Your Money's Worth" programs. Do you remember that?

CU: That was compiled from the answers of many thousands of readers who reported what had happened to their own TV sets. The information was put into a computer and we got some very interesting answers.

R-E: Yes; they interested me, for sure. Can you reveal the number of the sample?

CU: Yes, that's been printed. We queried more than 700,000 readers, and got a response of 108,000. Of course, that's still very small compared to the number of sets being used in the United States.

R-E: That's true. How was the test distributed geographically? You know, certain brands are more popular in one or another part of the country. Did you take that into account?

CU: We just took it the way our readers are distributed. But that doesn't affect the internal consistency of the data. We reported the service records per thousand sets surveyed. So I don't see how geographical distribution would have changed anything.

Incidentally, there has been a re-

examination of the data, and we have made one change. During subsequent further analysis, we found that the seemingly bad showing of RCA was due in a significant degree to the large number of color sets represented in their sample. Since color sets indeed require a good deal more repair than monochromes, we've found it necessary to correct the error and upgrade RCA sets from below average to average, where they really belong. The survey was intended to cover only monochrome.

R-E: Two groups lately have checked out service technicians by gimmicking a set that is supposed otherwise to be 100% okay. CU has done that?

CU: Yes, we did. The test was done in conjunction with the attorney general of New York and with WCBS-TV News.

R-E: I saw one such program on WCBS-TV, three 5-minute spots following their evening news shows.

CU: That's the one. A more complete report is in our February issue.

R-E: Did you see the one that ran on educational TV . . . the one sponsored by NET? It's the one that ran the statistics we just mentioned.

CU: Well, we saw the program. We know what it did, but that's about all. We had nothing to do with that one.

R-E: It seems to me this system of testing isn't fair. For example, say a fuse is blown. The first thing to do is wonder why it blew. If this customer lives 5 miles from the shop and I'm going to have to charge him to come back out there if it blows again, I'm going to re-

place also whatever I think might have made that fuse blow in the first place.

CU: I agree.

R-E: But something is missing in the tests conducted so far. I agree with checking questionable operators, and I'm agreeable to pushing fly-by-nights out of the business. But, on the other hand, the present method is not working fairly.

CU: I understand. The idea is, if a fuse blows, it's probably the high-voltage fuse. And the reason: the horizontal output tube may draw too much current—

R-E: Or the damper's arcing. Or the fly-back is shorting. Or the horizontal oscillator's quit.

CU: Right. You cannot just exchange the fuse. It would be stupid. So what you do is get to the cause of the trouble, and replace all that needs replacing. You get a new damper tube. You may need a new bypass condenser which broke down; you replace not only this condenser but a burnt resistor, too. You may even replace the horizontal output tube, because you are not sure that the old tube is still good after the overload. Now, when you're through with all this, you don't replace a tuner tube, do you?

R-E: Probably not. At least not for that complaint.

CU: That's the point. Unfortunately, there are some technicians who will tell a customer, "This whole thing was caused by some trouble in your loudspeaker or by some difficulty in your power supply."

R-E: I don't disagree. But in the program on NET, they were technically wrong. They called a circuit breaker a fuse, and they said they shorted it. A fuse is defective only when it's *not* a short—an open fuse.

CU: That's not the only place where this kind of testing was done. It was done in Chicago, in Milwaukee, California. . . .

R-E: One trouble is, they go pick a service technician to gimmick the set and they don't know if he's any more technically capable than the guys they're trying to entrap.

CU: In the CBS test, we were careful up to the last detail. We even used invisible ink and ultraviolet light on tubes and major parts to see when the sets came back whether returned tubes or parts were from the same set.

R-E: We would join with anybody to expose frauds, but the means of checking should protect those who are not fraudulent.

CU: I don't know how it's possible. A consumer does not know what he's up against. The set doesn't work—that's all he knows. We are trying to give him a little bit of help by telling him what to look for.

R-E: What you need is an article that tells the consumer how to find a good tech-

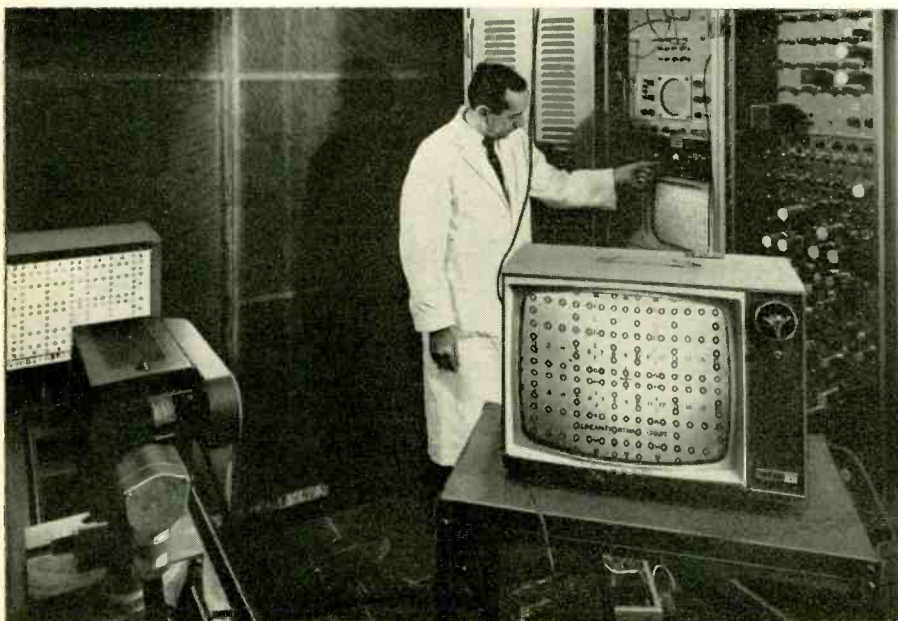

The TV camera (at left) scans a precise optical pattern, producing a linear video picture. This signal is then displayed on a set under test (right) to check linearity.

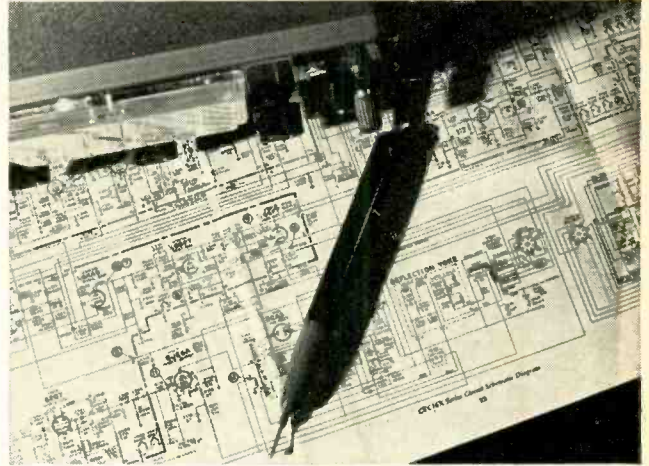



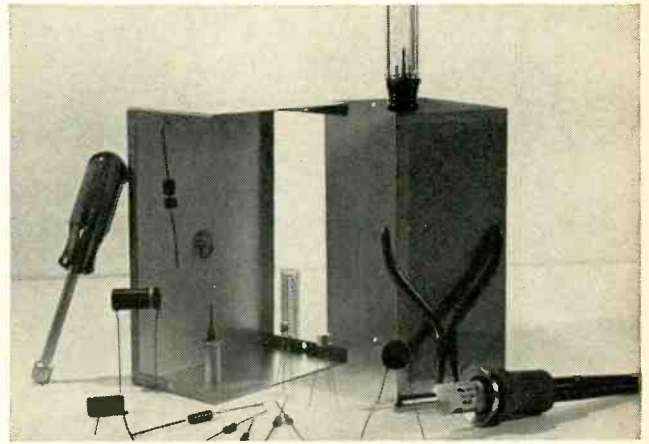
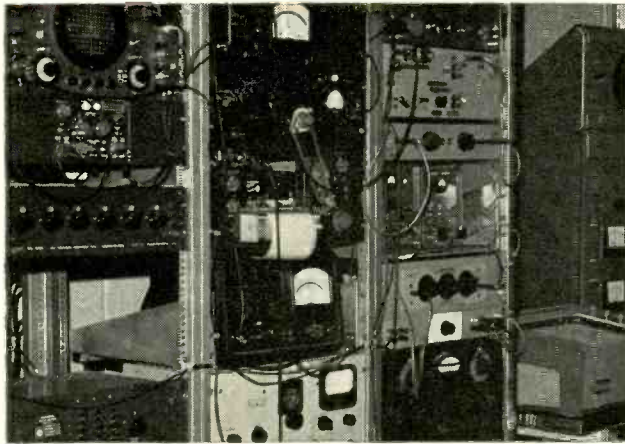









Whatever your electronics interest,



here are 12 powerful reasons why you should subscribe to RADIO-ELECTRONICS.

(besides the \$9.60 you can save over newsstand prices)

In 1966 more than 160,000 readers interested in every area of electronics learned from and profited by: January's Annual Color TV issue  February, which highlighted practical construction projects  March, a Hi-Fi/Stereo/Tape issue  April, a career series feature  May, which contained a line-up of home video recorders and their workings.  June, an annual issue on microcircuits and transistors  July's special section on Stereo FM  August's Test Equipment issue, which delved into do-it-yourself instrumentation  September, with CB and communications content for "two-ways"  October, full of the news in industrial electronics  November, which turned out to be a music issue featuring guitar amps, etc.  December, which featured electronic auto servicing  and its pros and cons. **You get all this ... plus monthly features like Jack Darr's Service Clinic ... reports on test equipment and audio components ... new products ... technotes ... new literature and books and more.**

Radio-Electronics



COMPLETE TUNER OVERHAUL

9⁹⁵

ALL LABOR AND PARTS (EXCEPT TUBES & TRANSISTORS)*



VHF UHF COLOR U-V TRANSISTOR

COLOR TUNERS GUARANTEED ALIGNMENT — NO ADDITIONAL COLOR CHARGE

Simply send us the defective tuner complete; include tubes, shield cover and any damaged parts with model number and complaint. Your tuner will be expertly overhauled and returned promptly, performance restored, aligned to original standards and warranted for 90 days.

UV combination tuner must be single chassis type; dismantle tandem UHF and VHF tuners and send in the defective unit only.

Exact Replacements are available for tuners unfit for overhaul. As low as \$12.95 exchange. (Replacements are new or rebuilt)

And remember—for over a decade Castle has been the leader in this specialized field . . . your assurance of the best in TV tuner overhauling.

CASTLE
TV TUNER SERVICE, INC.

5715 N. Western Ave., Chicago 45, Illinois
41-95 Vernon Blvd., Long Island City 1, N. Y.

For service in Canada write to Chicago or use reader service card in this magazine.
*Major parts are charged extra in Canada.

Circle 27 on reader's service card

Build your own AUTO ANALYZER
—and **SAVE!**

\$49⁹⁵



**It's FUN!
It's EASY! knight-kit®**
FROM
ALLIED RADIO
Headquarters for Everything in Electronics

Set Engine Idle—Auto Trans. Shift Points
CHECK:

- Distributor wear
- Dwell angle
- Voltage regulator
- Condensers
- Point surfaces
- Coil resistance
- Ground circuits
- Alternator diodes
- Engine timing
- Spark output and much more!

Save double on this famous Knight-Kit Auto Analyzer. Build it yourself and save factory assembly costs. Then use it for tuneups and troubleshooting to hold down car upkeep.

Write for special introductory offer.
No Money Down \$5 Monthly

ALLIED RADIO
Dept. 2F, P.O. Box 4398, Chicago, Ill. 60680
Circle 28 on reader's service card

Radio-Electronics Interviews Consumers Union

nician, how to tell the bad guys from the good guys.

CU: Not easy.

R-E: No, it isn't. But, to get back to this rigging of sets. When a poor job is done of gimmicking a set, and loaded facts and improper terminology are used in reporting results, it defeats the very purpose of the checking. No wonder it leaves the door open to accusations by the legitimate servicing industry of publicity-hunting. Maybe working together we could find a fair way. It would be an interesting approach, and would make an interesting article if it can be done. We'd like to help work on it.

CU: The TV repair piece in our February issue has a great deal more detail in it than appeared on the CBS TV spots. Incidentally, we should keep the record straight: The idea was not ours. CBS and the attorney general asked us to help, and we reported the tests exactly as they were done.

R-E: I know we and others improperly tied you in with the NET program last fall, simply because they did repeat your service-record chart near the end of the film.

CU: Only a portion of the chart, I might add. We never even gave them permission, because they didn't use *all* the information.

R-E: That is exactly what I feel happens so often when sets are gimmicked to entrap service shops who engage in unfair practices. I think the wrong faults are being put in, and then only part of the story is being told—often being thus a distortion.

CU: It seems insurmountable, almost.

R-E: It has been so rough on the honest technician for the last 5 years now that technicians may become almost a vanishing breed. There are several things wrong. One is that there are a lot of incompetents—an awful lot of them. This gimmicking approach weeds out only a few. That method has not really gotten to the root of the thing yet.

CU: Maybe licensing is one way.

R-E: Maybe. But anything that makes the field more difficult to enter will continue to scare away newcomers. If consumer-protection groups (and the industry itself deserves a load of the blame) continue to paint the servicing field as a dishonest undertaking, there'll come a time when thousands of home-entertainment electronic devices will be sitting idle for lack of repairs. What is needed is to make the field a highly paid, clean, prestigious, and attractive one so that youngsters will be encouraged to become competent. Licensing can't do all that.

CU: But it could be a first step. Of course, you know that this problem extends throughout the servicing industry, not just electronic servicing. Auto repair is probably the biggest one.

R-E: I don't think auto repair has nearly the black eye electronic servicers have. The auto manufacturers have helped nationally to build better images for mechanics.

CU: That's right. And the electronics-industry manufacturers have not taken any clear steps.

R-E: They have, but only behind the scenes. They haven't gotten behind the service technician nationally. Maybe that is the next step. They're offering more and better training to technicians, even though it's product-oriented. But they need to help in a mass public-education campaign, to show consumers what they can fairly expect. Neither your article nor the NET program has come close to giving the public the information they need to judge fairly a technician's performance. Nor will doing the repairs themselves help much, any more than it does with autos—probably much less.

The answer is education, and that's a job we can both work at. Associations, manufacturers and vocational schools are laboring to instill pride and competency into the technicians now in the business and who will be entering soon. We can amplify their efforts by convincing technicians that competency goes further than merely being able to pass a written exam or make a neat solder joint in the right circuit. Competency is having your hair combed, wearing a clean shirt, speaking politely, taking the time to tell a "dumb" customer the details of a repair job, keeping cigarette ashes off the carpet, putting all the screws back in, giving back the faulty parts, and—that misty attribute—acting like a professional.

Consumer Reports, and all other mass magazines and media (TV, radio, etc.), will be doing a favor to their consumer readers if they can educate them to the facts of electronic servicing. You have RADIO-ELECTRONICS' pledge of assistance with any program or series of articles to tell this story accurately.

We do not condone the whitewashes that inevitably follow the tar-and-feather exposés; they are often as unfair, biased and useless as the incomplete stories that provoke them. What we propose is a coordinated program that will clear up the misunderstandings of both consumer and technician. When the air is clear, there will no longer be a shortage of qualified technicians to maintain the electronics of the country. **END**

Coming Next Month . . . in JULY

Radio-Electronics

A real bargain package for the technician, engineer, builder, experimenter, expert, novice—everyone who takes his electronics seriously

COMING

to service and laboratory technicians, experimenters and electronic hobbyists an issue crammed with valuable how-to-build, how-to-use and how-it-works information on a variety of useful test instruments. A typical example is the TV dot-bar generator featured on next month's cover.

NEXT

time you try to sweep align an FM set with a TV sweep generator, you'll again wish for equipment designed especially for the job at hand. Be prepared. Build the FM sweep generator in the July issue.

MONTH

in and month out, you test, service and experiment with electronic equipment and circuits while using makeshift apparatus and outmoded methods. Update your equipment and techniques for increased profit and fun. It's all going to be there in the July issue of RADIO-ELECTRONICS

Make sure you get this valuable issue. Order your subscription or tell your distributor or newsstand dealer to save you a copy! On sale June 22.

The JULY 1967 Special
Issue of **Radio-Electronics**



The image shows the Sencore TR139 Dynamic In-Circuit Transistor Tester. It is a rectangular device with a control panel on the front. The panel features a large analog meter with two scales: 'AC BETA' and 'LEAKAGE'. Below the meter are several control knobs and switches, including a 'TRIP POINT' knob and a 'DYNAMIC IN-CIRCUIT TRANSISTOR TESTER' label. The device is shown with its carrying case open and test leads connected. Above the device, there are icons for a transistor, a diode, and a rectifier, indicating the types of components it can test.

TEST TRANSISTORS IN SECONDS in circuit

TR139
89⁵⁰

Also check all
transistors, diodes,
and rectifiers out
of circuit for true AC beta
and Icbo leakage.

Your best answer for solid state servicing, production line testing, quality control and design.

Sencore has developed a new, dynamic in-circuit transistor tester that really works—the TR139—that lets you check any transistor or diode in-circuit without disconnecting a single lead. Nothing could be simpler, quicker or more accurate. Also checks all transistors, diodes and rectifiers out of circuit.

BETA MEASUREMENTS—Beta is the all-important gain factor of a transistor; compares to the gm of a tube. The Sencore TR139 actually measures the ratio of signal on the base to that on the collector. This ratio of signal in to signal out is true AC beta.

ICBO MEASUREMENTS—The TR139 also gives you the leakage current (Icbo) of any transistor in microamps directly on the meter.

DIODE TESTS—Checks both rectifiers and diodes either in or out of the circuit. Measures the actual front to back conduction in micro-amps.

COMPLETE PROTECTION—A special circuit protects even the most delicate transistors and diodes, even if the leads are accidentally hooked up to the wrong terminals.

NO SET-UP BOOK—Just hook up any unknown transistor to the TR139 and it will read true AC beta and Icbo leakage. Determines PNP or NPN types at the flick of a switch.

Compare to laboratory testers costing much more. . . . \$89.50

See America's Most Complete Line of Professional
Test Instruments — At Your Distributor Now.



NO. 1 MANUFACTURER OF ELECTRONIC MAINTENANCE EQUIPMENT

SENCORE

426 SOUTH WESTGATE DRIVE, ADDISON, ILLINOIS 60101

Circle 29 on reader's service card

65

EQUIPMENT REPORT

Heathkit-Magnecord Model AD-16

Professional Tape Recorder

Circle 30 on reader's service card



A FELLOW CAN BECOME ADDICTED TO kit-building. If he really likes working with electronics, building kits easily becomes a habit that's hard to kick. As he gains experience and confidence, some kit projects begin to seem too easy. He starts shopping around for something to give him a bit of a challenge.

The Heathkit/Magnecord recorder is both a challenge and a pleasure. It

takes as much time to build as a color TV set, and the mechanical portions might scare away even the most serious kit-buff, who is often a whiz with a soldering gun but a fumble-fingers with a wrench. The model AD-16 is worth the trouble. Once built, it functions smoothly and cleanly, both mechanically and electronically.

In all fairness, the mechanical con-

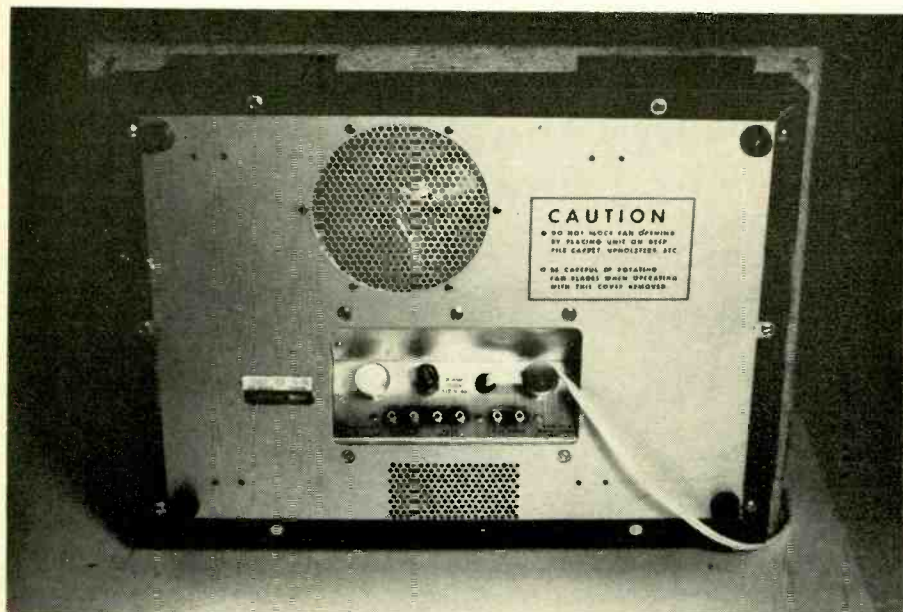

AD-16 will operate vertical or horizontal, so jacks are recessed on a bottom subpanel.

struction isn't difficult. In fact, by the time I'd finished putting together my AD-16, I knew the mechanism of that tape recorder like the inside of my own den. This was a fine short course on how a tape recorder works. You're not messing around with cost-saving shortcuts in this mechanism; the machine is a top quality one, and it's designed for performance, not economy.

There's a lot to do, building the AD-16. You who have built kits will know what I mean when I tell you I had a stiff neck before I'd finished pushing 111 resistors, 79 capacitors, 21 transistors, 4 diodes, and some chokes and controls into an extremely large circuit board, soldering them in, and clipping off the leftover leads. After that, there were ganged switches to mount and wire up. Twelve hours, it took, up to that point.

The next steps were bolting together the chassis, getting the power supply assembled, installing a wiring harness, and mounting the completed circuit boards. This took almost another 6 hours.

Then what turned out to be the most enlightening part: building the transport. It's mechanical and it's a lot of work—6 hours and 40 minutes' worth. But I have to admit I enjoyed building the mechanical portion best of all. Maybe it was because it was so different from assembling just an electronic kit. Mostly, though, I think it was the feeling of knowing—of learning the mechanics of that recorder intimately.

Counting unpacking time, I now had nearly 26 hours in constructing the AD-16. The instructions said, "Proceed to the Initial Test and Adjustment section." Testing and adjusting the recorder by the manual took 2 more hours. It sounded pretty good then, but I got out my own alignment tape and a scope and did a really careful job of setting the recording bias and aligning the heads. I spent an extra hour, and got a measurable improvement.

Finally, the cabinet, and the job was done. It had all taken 30 hours, but what a dream of a machine. The performance and versatility of this recorder makes it a perfect addition to the music system of the serious buff. I've recorded stereo concerts from my multiplex tuner; sound is great, and separation excellent.

For a quality instrument, you expect to pay. For this one, you pay over \$400, counting a cabinet. The AD-16 is the same as the Magnecord 1020—one of the top nonbroadcast recorders—yet the Heathkit costs almost \$200 less. Not a bad saving for the time spent. And the rewards extend well beyond money.

—Alan James

Price: Kit \$399.50

END

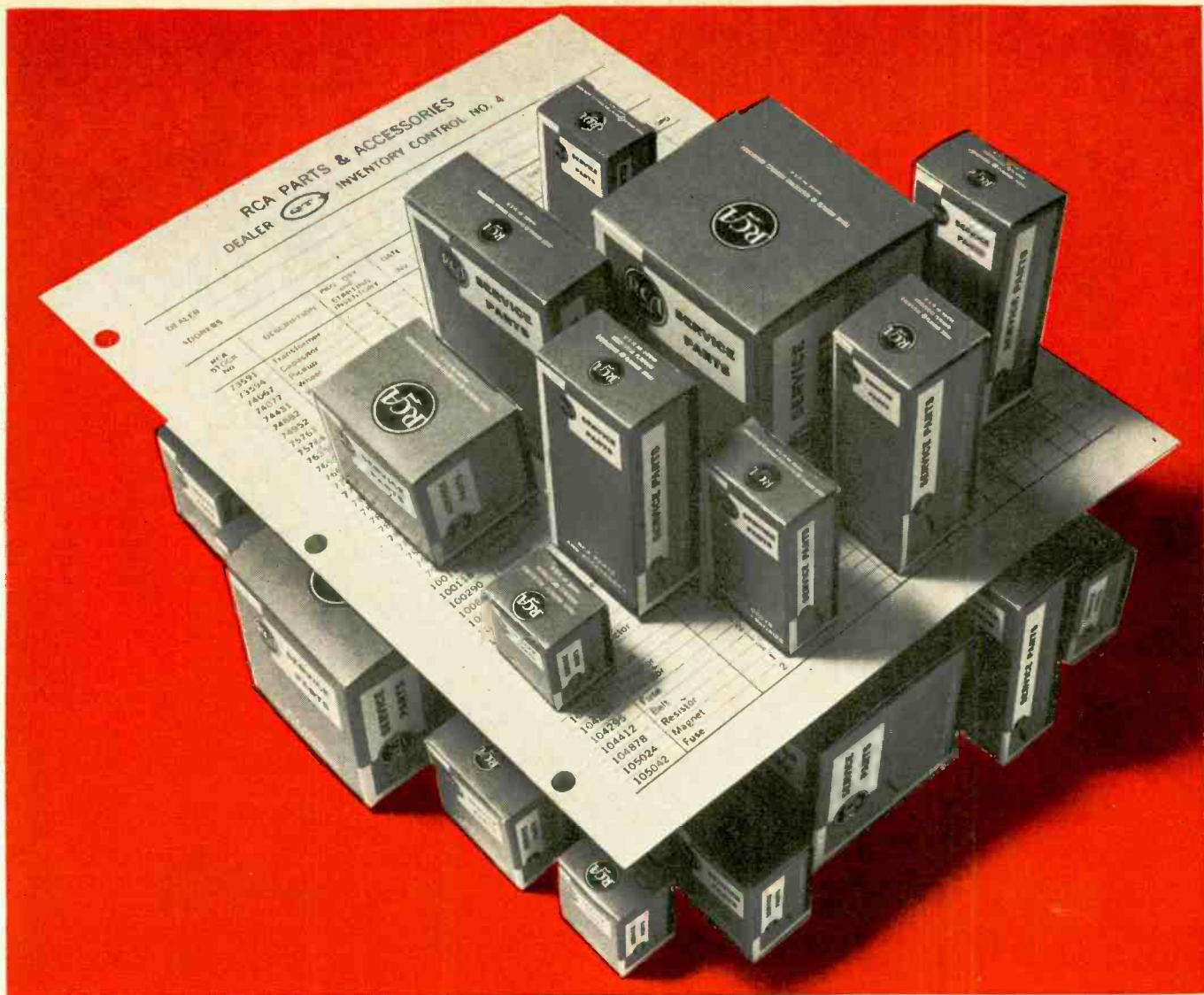

New help from RCA to reduce your loss-time...increase your profits

An RCA "QT" Inventory takes the guesswork out of stocking replacement parts... puts the most used RCA home instrument parts at your fingertips.

Your RCA Replacement Parts Distributor has a computer planned inventory program that makes your job easier. It will help you improve efficiency, speed up customer service, reduce inventory liability, and increase profits.

RCA "QT" (Quick Turnover) Inventories are designed to suit various-size service operations, with varying quantities of the most used RCA Home Instruments Replacement Parts.

These inventories are reviewed and updated semi-annually in accordance with the most current usage data, based on an analysis by RCA Electronic Data Processing Equipment of national sales patterns.

Once you get the "QT" habit, you have what's needed to produce better service, satisfied customers and additional business.

There are so many advantages to the RCA "QT" Inventory Program that it will be worth your time to call your RCA Distributor and ask him about them. Call him *today*—and start enjoying the profitable benefits that can be yours.



RCA PARTS AND ACCESSORIES, Deptford, New Jersey

The Most Trusted Name in Electronics

The World's Best Values In Test



Kit IM-25 Assembled
\$80.00 \$115.00

NEW! Solid-State High Impedance Volt-Ohm-Milliammeter

- Solid-state design for solid-state measurements • All-silicon transistors plus FET's • Full scale ranges down to 150 mv & 15 uA • AC plus battery power for portability • 6" meter with zero center scale for + & - voltage measurements without switching • Accuracy $\pm 3\%$ full scale on DC volts, $\pm 5\%$ full scale on AC volts • New styling & unitized construction • Separate range switches for each function. 10 lbs.

World's Most Popular VTVM ... Heathkit IM-11

Kit IM-11
\$24.95

Assembled
\$39.95



- 7 AC, 7 DC, & ohms ranges — easy-to-read scales • $4\frac{1}{2}$ ", 200 uA meter • 1% precision resistors for high accuracy • Extended frequency response, ± 1 db 25 Hz to 1 MHz • Measures RMS and Peak-to-Peak • Single test probe for all measurements • Easy-to-build, electronically stable circuit board construction • Costs just 45¢ more than its predecessor of 16 years ago. 5 lbs.



Kit IM-13 Assembled
\$32.95 \$49.95

Service-Bench VTVM ... Ideal For In-Shop Servicing

- Measures AC volts (RMS), DC volts, resistance & db • Separate 1.5 & 5 volt AC scales for high accuracy • Large, easy-to-read 6", 200 uA meter • Zero center db scale • Single test probe for all measurements • Gimbal bracket for bench, shelf or wall mounting • Smooth vernier controls for zero & ohms adjust • 1% precision resistors. 7 lbs.

Mutual Conductance Tube Tester



Kit TT-1A
\$149.95

- No finer tube tester anywhere • Indicates Gm to 24,000 micromhos • Ultra-sensitive grid current test • Built-in switch-operated calibration circuit for high accuracy • Built-in adaptor for testing Compactron, Nuovistor, Novar & 10-pin miniature tube types • Includes handsome, easy-to-carry cabinet with handle. 33 lbs.



Capacitor Checker ... A Direct Reading Bridge

Kit IT-11
\$29.95

- Tests all capacitor types • Low bridge voltage for safe testing of miniature electrolytics • 16 leakage testing voltages • Direct reading scales — no involved calculations • Measures resistance from 5 ohms to 50 megohms • Measures capacitance from 10 pf to 1000 uf • Comparator circuit — measures "L", "C", or "R" with external standard • "Eye" tube null & leakage indicator. 7 lbs.

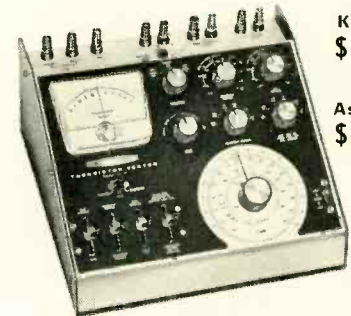

Kit IM-30
\$54.88

Assembled
\$84.95

Lab Transistor Tester Provides Complete DC Analysis

- Ideal for servicing, design work, incoming inspection, production testing, etc. • Provides complete DC analysis of PNP & NPN transistors to 15 amps • DC gain (Beta, Alpha) read direct on calibrated scales • 15 uA basic range for leakage (Icbo, Iceo) tests • Four lever switches for fast, easy test selection • Internal battery supply, provisions for external power. 10 lbs.



Kit IG-112
Was \$99.00 \$69.00
Now Only

NEW LOW PRICE! Now Save \$30 On FM Stereo Generator

- Provides virtually all signals required for trouble-shooting & alignment of multiplex adaptors, FM tuners & receivers • Switch selection of 400 Hz, 1000 Hz, 5000 Hz, 19 kHz, 38 kHz and 65 kHz or 67 kHz SCA signals • Built-in marker oscillator for I.F. and dial tracking checks • 100 MHz sweep signal (adjustable ± 2 MHz) for overall RF & IF alignment on clear area of FM band. 11 lbs.



General Purpose RF Signal Generator

Kit IG-102
\$27.95

Assembled
\$54.95

- Covers 100 kHz to 220 MHz in six bands • Large, accurately calibrated dial scales • Factory wired and aligned coil and band-switch assembly • Modulated or unmodulated RF output up to 100,000 microvolts, controlled by both fixed-step or variable output attenuators • 400 Hz signal modulation and 400 Hz audio output for audio tests • 2% tuning accuracy. 7 lbs.

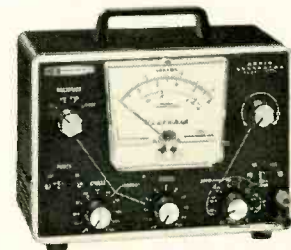

Kit IG-72
\$41.95

Assembled
\$64.95

Switch-Selected Audio Generator for Near Perfect Sine-Wave Signals

- A near perfect output signal — ideal for servicing or trouble-shooting high fidelity equipment • Switch-selected output frequencies — 10 Hz to 100 kHz • Less than 0.1% of 1% distortion — 20 to 20,000 Hz • Panel metered output is calibrated in volts and db • Output level and frequency accurate to within $\pm 5\%$ • 200 uA meter plus precision resistors for high accuracy. 9 lbs.

Circle 32 on reader's service card

Instruments Come From HEATH!

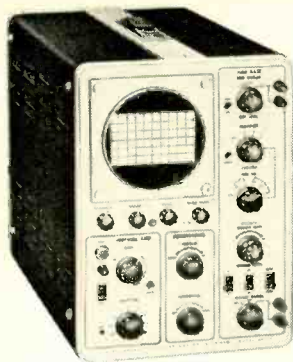

Kit IO-14
Was \$299
Now Only
\$259.00
Assembled
\$399.00

NEW LOW KIT PRICE! Now Save \$40 On Professional 5" DC Oscilloscope

- A high stability 5" DC oscilloscope with triggered sweep • DC to 8 MHz bandwidth and 40 nanosecond rise time • Vertical signal delay through high linearity delay lines — capable of faithful reproduction of signal waveforms far beyond the width of the scope • Calibrated vertical attenuation • Calibrated time base • Forced air cooling • Input of Z-axis modulation. 53 lbs.

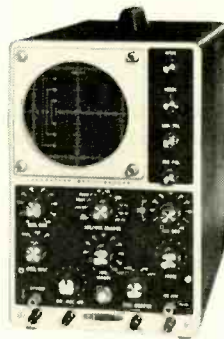

Kit IO-12
\$81.95
Assembled
\$137.50

Extra-Duty Wide-Band 5" Oscilloscope

- Ideal for TV trouble-shooting, professional & university labs • 5 MHz bandwidth for TV signal analysis • Heath patented sweep circuit — 10 Hz to 500 kHz • Two extra sweep switch positions which may be adjusted to often used sweep rates • Built-in peak-to-peak calibration reference • Combination of circuit board and wiring harness construction speed assembly time. 24 lbs.

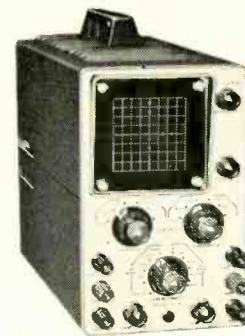

Kit IO-10
\$94.95

"Space-Saver" 3" DC Oscilloscope

- Identical vertical & horizontal DC or AC coupled amplifiers • DC to 200 kHz bandwidth — less than 5° phase shift • Recurrent sweep generator, 5 Hz to 50 kHz in four ranges • External capacitor binding posts for slower sweep rates • Small, compact, easy to carry from job to job • All critical voltages regulated for high stability • Transformer operated power supply. 16 lbs.



PKW-2
\$12.00

NEW Low Capacitance Scope Probe

- Completely assembled, ready to use • Essential for high frequency wave-form analysis • Minimizes loss of gain, circuit loading or distortion • Designed for scopes with 1 megohm input, such as Heathkit IO-14 (above) • Switch for X1 direct or X10 attenuated operation • DC response to 25 MHz; max. DC voltage is 600 v. • Sliding, spring-loaded tip is notched for hooking to wires or terminals for hands-free use. 1 lb.



Kit ID-22
\$23.95

Electronic Switch For Dual-Trace Scope Operation

- Permits display of two separate signals on CRT screen • Displays signal levels as low as 0.1 volt • ± 1 db, 0-100 kHz response • Separate gain controls for each channel • All-electronic switching • Four switching rates — 150, 500, 1500 and 5000 Hz • Sync output to control scope sweep • Simple to use — just connect signal sources to "A" and "B" inputs & output to scope vertical input. 7 lbs.



Kit IO-21
\$58.95

General Purpose 3" Oscilloscope

- Push-pull vertical and horizontal amplifiers for minimum trace distortion • Wide-range sweep — 20 to 100,000 Hz • Automatic sync • Retrace blanking • Compact, lightweight, versatile • Dependable, well-rated oscilloscope for general purpose requirements • Professional-quality components used throughout • Clean, open circuit layout for easy assembly. 12 lbs.



Kit IG-52
\$67.95

TV Alignment Generator

- FM & TV coverage — Sweep oscillator covers 3.6 MHz to 220 MHz with 0-42 MHz max. sweep width • Stable, all-electronic sweep circuit • Built-in marker oscillators — 4.5 MHz crystal & 19 to 60 MHz variable. 14 lbs.

Color Bar & Dot Generator

- Produces 6 different patterns for picture adjustment • 10 vertical color bars — including special shading bar pattern • Crystal controlled for accuracy & stability • RF & video output. 13 lbs.



Kit IG-62
\$64.95



FREE!

World's Largest Electronic Kit Catalog!

Describes these and over 250 kits for stereo/hi-fi, color TV, amateur radio, shortwave, test, CB, marine, educational, home and hobby. Save up to 50% by doing the easy assembly yourself. Mail coupon or write Heath Company, Benton Harbor, Michigan 49022

HEATH COMPANY, Dept. 20-6
Benton Harbor, Michigan 49022
In Canada, Daystrom Ltd.

Enclosed is \$ _____, plus shipping.

Please send model (s) _____

Please send FREE Heathkit Catalog.

Name _____

Address _____

City _____

State _____

Zip _____

Prices & specifications subject to change without notice.

TE-162



RADIO-ELECTRONICS READER'S SERVICE

Here's how you can get manufacturers' literature fast:

1. Tear out the post card on the facing page. Clearly print or type your name and address.

Include zip code! Manufacturers will not guarantee to fill your requests unless your zip code is on the reader service card!

2. Circle the number on the card that corresponds to the number appearing at the bottom of the **New Products, New Literature** or **Equipment Report** in which you are interested.

For literature on products advertised in this issue, circle the number on the card that corresponds to the number appearing at the bottom of the advertisement in which you are interested. Use the convenient index below to locate quickly a particular advertisement.

3. Mail the card to us (no postage required in U.S.A.)

Advertisements in this issue offering free literature (see the advertisements for products being advertised):

ALLIED RADIO CORP. (Pg. 64)	Circle 28	MICROFLAME, INC. (Pg. 83)	Circle 118
ARCTURUS ELECTRONICS CORP. (Pg. 90)	Circle 133	MULTICORE SALES CORP. (Pg. 86)	Circle 137
B & K MANUFACTURING CO., INC. (Pg. 13)	Circle 13	MUSIC ASSOCIATED (Pg. 87)	Circle 139
BROOKS RADIO & TV CORP. (Pg. 86-87)	Circle 138	OLSON ELECTRONICS, INC. (Pg. 74)	Circle 107
BROWNING LABORATORIES, INC. (Pg. 82)	Circle 116	OXFORD TRANSDUCER CO. (Pg. 16)	Circle 16
CASTLE TV TUNER SERVICE, INC. (Pg. 64)	Circle 27	PERMOFLUX CORP. (Pg. 79)	Circle 114
CLEVELAND INSTITUTE OF ELECTRONICS (Pg. 7)	Circle 11	POLY PAKS (Pg. 95)	Circle 147
CLEVELAND INSTITUTE OF ELECTRONICS (Pg. 28-31)	Circle 26	RADIO SHACK (Pg. 1)	Circle 8
CORNELL ELECTRONICS CO. (Pg. 94)	Circle 146	RYE INDUSTRIES, INC. (Pg. 82)	Circle 115
DATAK CORP. (Pg. 78)	Circle 112	RYE INDUSTRIES, INC. (Pg. 83)	Circle 117
DELTA PRODUCTS, INC. (Pg. 75)	Circle 109	SALCH & CO., HERBERT (MARKETING DIVISION OF TOMPKINS RADIO PRODUCTS) (Pg. 76)	Circle 110
DEVRY INSTITUTE OF TECHNOLOGY (Pg. 5)	Circle 9	SAMS & CO., INC., HOWARD W. (Pg. 6)	Circle 10
EDMUND SCIENTIFIC CORP. (Pg. 93)	Circle 144	SCIENTIFIC ASSOCIATES CORP. (Pg. 14)	Circle 14
ELECTRO-VOICE, INC. (Pg. 25)	Circle 23	SENCORE (Pg. 65)	Circle 29
FINNEY CO. (Pg. 74)	Circle 108	SENCORE (Pg. 85)	Circle 136
FINNEY CO. (Pg. 90)	Circle 132	SOLID STATE SALES (Pg. 92)	Circle 142
HEALD ENGINEERING COLLEGE (Pg. 89)	Circle 134	SONOTONE CORP. (ELECTRONIC APPLICATIONS DIV.) (Pg. 22)	Circle 24
HEATH COMPANY (Pg. 27)	Circle 25	SONY CORP. OF AMERICA (Pg. 26)	Circle 19
HEATH COMPANY (Pg. 68-69)	Circle 32	SPRAGUE PRODUCTS CO. (Pg. 24)	Circle 22
INTERNATIONAL CRYSTAL MFG. CO. (Pg. 96)	Circle 148	SURPLUS CENTER (Pg. 89)	Circle 141
JERROLD ELECTRONICS CORP. (DISTRIBUTOR SALES DIVISION) (Pg. 23)	Circle 21	TECHPRESS, INC. (Pg. 84)	Circle 135
JFD ELECTRONICS CORP. (Pg. 17)	Circle 17	TEXAS CRYSTALS (Pg. 89)	Circle 140
JUDSON RESEARCH AND MFG. CO. (Pg. 76)	Circle 111	TRIPLETT ELECTRICAL INSTRUMENT CO. (Second Cover)	Circle 7
LAFAYETTE RADIO ELECTRONICS (Pg. 78)	Circle 113	UNITED RADIO CO. (Pg. 93)	Circle 143
MALLORY DISTRIBUTOR PRODUCTS CO. (Third Cover)	Circle 149	WARREN ELECTRONIC COMPONENTS (Pg. 94)	Circle 145
		XCELITE, INC. (Pg. 12)	Circle 12

NEW PRODUCTS

More information on new products is available free from the manufacturers of items identified by a Reader's Service number. Turn to the Reader's Service Card facing page 70 and circle the numbers of the new products on which you would like further information. Detach and mail the postage-paid card.

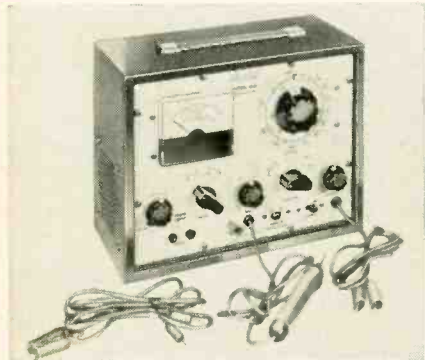

RADIO ANALYZER, Model 860 Injector-Tracer. Solid-state. Combines signal injection, signal detection, and power source. 1,000-Hz audio, rf over the range of 240-1,750 kHz plus 10.7 MHz FM i.f. Tunable amp also covers 240-1,750 kHz. Voltage output, 0-15 V; current range, 0-1,000 mA. \$149.50—Hickok Electrical Instrument Co.

Circle 46 on reader's service card



GUITAR DISTORTER. Transistorized input booster circuit. Cast-aluminum case. Separate volume and depth controls. Foot- or hand-operated. \$39.95.—Kent Musical Products

Circle 47 on reader's service card



SOLDERLESS TERMINAL KIT, ATK-901. Preinsulated. Kit includes model 10000 crimping tool.—Aerovox Corp.

Circle 48 on reader's service card

ELECTRONICS LAB AND COURSE, Practronics. 3 programed Practibooks plus lab with power sources and

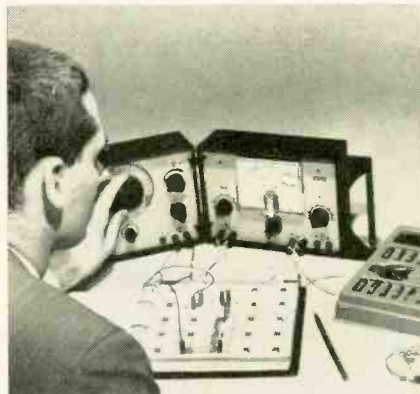

measuring instruments. Covers fundamentals of resistance, capacitance, and inductance. Approximately 120 hr. \$350.—North American Philips Co., Inc.

Circle 49 on reader's service card



COLOR GENERATOR, model 1900. Solid-state. Line-width adjuster. Separate horizontal and vertical bars. Crystal-controlled color display for circuit testing, adjusting.—Mercury

Circle 50 on reader's service card

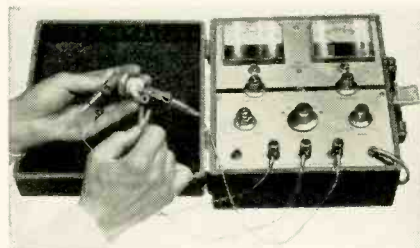

THYRISTOR (SCR) ANALYZER, model 240. Solid-state. Portable. 115 Vac. 10½ x 9 x 5 in. \$144.50.—Seco Electronics

Circle 51 on reader's service card

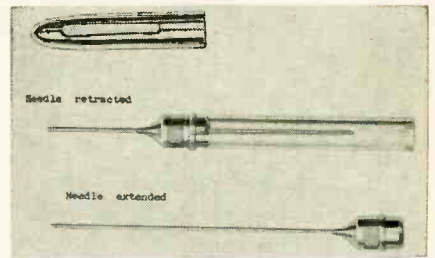

POCKET TELESCOPIC OILER, Long-Nose-Jr. Telescoping. 062-in. brass needle adjusts 1-3½ in. Plastic oil chamber

At last!



Model AA-100

A compact transistor audio amplifier

Features:

- 5 Transistors and 1 Thermistor
- Shielded Input Transformer with TWO PRIMARY WINDINGS... 50 Ohms and High Impedance
- Output Transformer with TWO SECONDARY WINDINGS... 8 Ohms (for Speakers), 500 Ohms (for Modulation and High Impedance Loads)
- Volume Control Included and Mounted on Circuit Board
- Low Distortion... 200 Milliwatt Push-Pull Output
- Extremely High Gain... 80 DB! Handles low-level mikes, phono pickups, telephone pickups, etc.
- Sturdy Printed Circuit Board 5½" long, 1¾" wide
- Weight... 3½ ounces
- Power Supply... Any 9-Volt DC Source

Use it for:

- | | |
|---------------------------------|---------------------------|
| PA System | Intercom Amplifier |
| Hi-Fi System (Use 2 for Stereo) | Modulator for Transmitter |
| Guitar Amplifier | Phono Amplifier |
| Surveillance Listening System | Utility Amplifier |
| Electronic Stethoscope | Science Projects |

COMPLETE AMPLIFIER \$6.95 each including SCHEMATIC DIAGRAM We pay postage!

ROUND HILL ASSOCIATES INC.
A MILO ELECTRONICS SUBSIDIARY
434 Avenue of the Americas, New York, N. Y. 10011

Please rush me _____ (qty) of your compact transistor audio amplifiers at \$6.95 each post-paid. My check or money order for \$ _____ is enclosed.

NAME _____
ADDRESS _____
CITY _____ STATE _____ ZIP _____

Olson



FREE

Fill in coupon for a **FREE** One Year Subscription to **OLSON ELECTRONICS' Fantastic Value Packed Catalog**—Unheard of **LOW, LOW PRICES** on Brand Name Speakers, Changers, Tubes, Tools, Stereo Amps, Tuners, CB, Hi-Fi's, and thousands of other Electronic Values. Credit plan available.

NAME _____
 ADDRESS _____
 CITY _____ STATE _____
 GIVE ZIP CODE _____

If you have a friend interested in electronics send his name and address for a **FREE** subscription also.

OLSON ELECTRONICS, INC.

588 S. Forge Street Akron, Ohio 44308

Circle 107 on reader's service card

NOW...PERFECT COLOR TV

ELIMINATE FM and OTHER INTERFERENCE

With the Sensational

NEW FINCO

FM Trap (Blocks Out FM)



MOUNTS EASILY BEHIND TV SET

MODEL 3006

Get pure color signals for perfect color reception. Use a Finco Model 3006 to stop interference and block out unwanted signals from FM, Citizens Band, Amateur transmitters, motors, autos, aircraft, and fluorescent lamps. Size: 4¼" x 2" x 1½". Available at your Finco dealer.

Model 3006

Only \$6.25 List

THE FINNEY COMPANY

34 W. Interstate St. Dept. RE
 Bedford, Ohio 44014

"FINCO ANTENNAS CAPTURE THE RAINBOW"

Circle 108 on reader's service card

NEW PRODUCTS continued

holds ¼ oz. Dustproof metal cap. \$1.—
 Gaunt Industries

Circle 52 on reader's service card

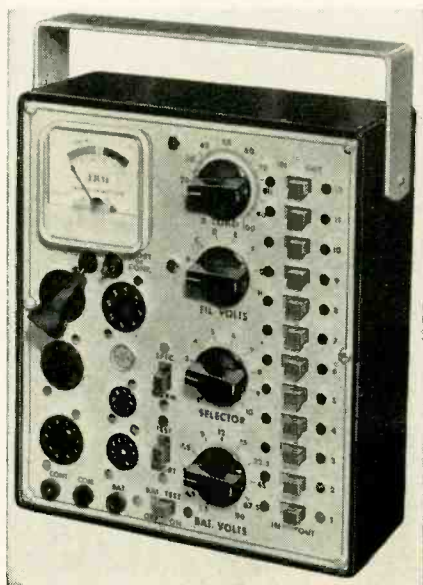

TUBE TESTER, model 636. Transformer isolation, 3-color meter, neon-lamp short indicator, 117 Vac. 60 Hz. 8¾ x 7½ x 3¾ in., 4 lb. \$34.95.—EICO

Circle 53 on reader's service card



VARIABLE AUTOTRANSFORMERS, models 1000, 1200, 1020, and 1030. Rated at 10, 12.5, 3.5 and 5 amps, respectively. Epoxy-coated coils. 1000 and 1200 operate from 120 V; 1020 and 1030 from 240 V. Single- and 3-phase; manual or motor-driven. Encased or open. Some units provided with pilot light, line-over-voltage switch, fuse.—Staco, Inc.

Circle 54 on reader's service card

VACUUM-TUBE VOLTMETER, model 806. 8-in. meter. 0.5 full-scale dc range. 3% accuracy. Portable. Measures complex waveforms from 0.2 to 4,200 V peak-to-peak; rms values of sine waves

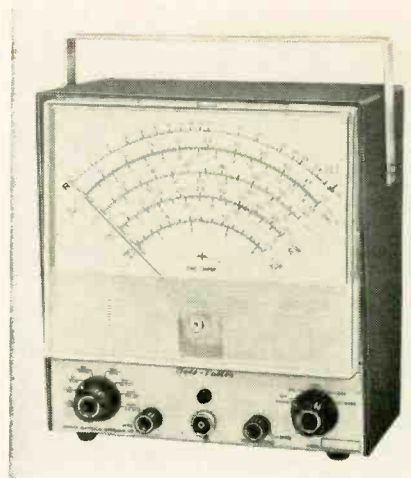

from 0.1 to 1,500 V in 7 overlapping ranges; dc voltages from 0.1 to 1,500 V in 8 overlapping 3-to-1 ranges; input impedance, 11 megs. Resistance from 0.2 ohm to 1,000 megs in 7 overlapping ranges.—Electronics Division, Singers Products Co., Inc.

Circle 55 on reader's service card

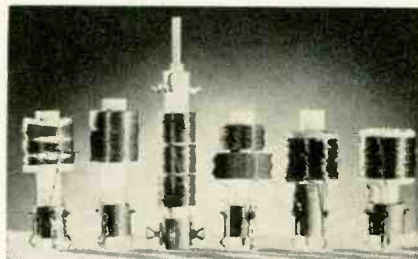

CIRCUIT REPLACEMENT COILS. Interchangeable with original coils in color TV sets.—J. W. Miller Co.

Circle 56 on reader's service card

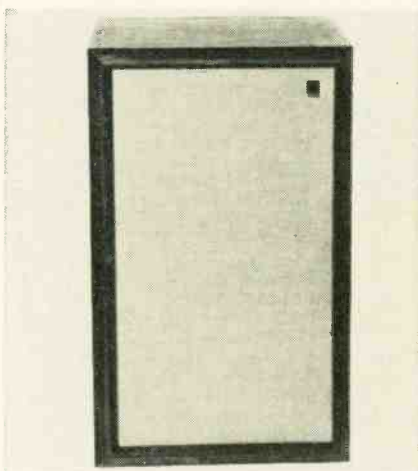

CONTROLLED IMPEDANCE SPEAKER, model S-11. For use with solid-state equipment. 3-way. 24 x 14 x 11¼ in. \$149.95.—H. H. Scott, Inc.

Circle 57 on reader's service card

31-CHANNEL TRANSCEIVER, Poly-Comm 30. Uses frequency synthesis.

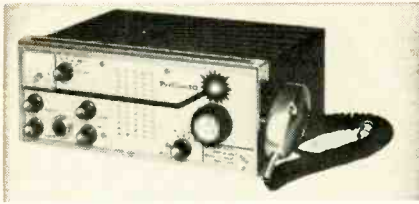

Dual-conversion superheterodyne. Nuvis-
tor rf amplifier and mixer stages. Sensitivity
0.15 μ V for 10 dB S/N. Squelch, vari-
able noise limiter. Electronic switching
prevents changing to high power on Part-
15 channels. \$329.50.—Polytronics

Circle 58 on reader's service card



REMOTE CONTROL SYSTEMS.
Teleswitch, TSW-2; Sound-Off, TSW-3.
Solid-state. Wireless, operates up to 40
ft. For turning devices of 7.5 amps or 850
W on or off. Battery-supplied remotely.
\$22.95.—Euphonics

Circle 59 on reader's service card



**TAPE CARE KIT, No. 30-636, Blast-
Off, No. 30-630.** Kit contains cleaner, lu-
bricant, 10 cartridge pouches. \$3.49.
Blast-Off is a head-cleaning compound.
\$1.95—GC Electronics Co.

Circle 60 on reader's service card

**PRINTED-CIRCUIT ASSEMBLIES
AND KITS.** For mono and stereo transis-

Why settle for less? Buy the Best!
THE FABULOUS
MARK TEN CAPACITIVE DISCHARGE
IGNITION SYSTEM

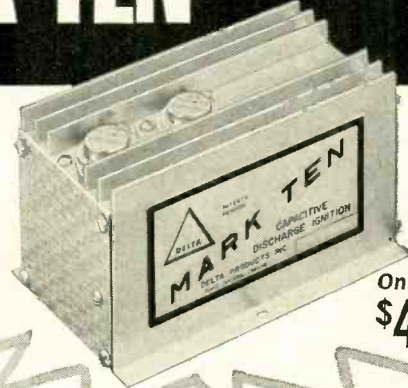

Available in
easy-to-build
kit form
at only

\$2995
ppd.!

Only
\$4495
ppd.!

Dramatically improve the performance of
your car—or any vehicle. Racers and
Pacers from Sebring to Suburbia by the
thousands attest to the peerless perform-
ance of the Mark Ten. Delta's remarkable
electronic achievement, proven for four
years, is often copied, never excelled.

Ready for these?

- ▲ Dramatic increase in acceleration
- ▲ Longer point and plug life
- ▲ Improved gasoline mileage
- ▲ Complete combustion
- ▲ Smoother performance

Ready? Order today!

BE YOUR OWN MECHANIC



Tune-up

DWELL METER \$12.95 ppd.

A universal precision instru-
ment for use in tuning all
vehicles, regardless of the
number of cylinders or batter-
y polarity. Gives correct
point dwell readings on ve-
hicles equipped with capaci-
tive discharge, transistor or
conventional ignition. Preci-
sion accuracy at low cost.

- ▲ Portable, high-impact case for
rugged work
- ▲ Large, easy-to-read 3 1/2 inch
precision jeweled meter
- ▲ Wide scale — reads dwell angles
in degrees
- ▲ All solid state



Tune-up

TACHOMETER \$14.95 ppd.

A universal precision instru-
ment for making carburetor
adjustments on all vehicles,
regardless of the number of
cylinders or battery polarity.
Gives precise RPM readings
on vehicles equipped with
capacitive discharge, transis-
tor or conventional igni-
tion. Gives you better gas
mileage, fuel savings and
peak engine operation.

- ▲ Large, easy-to-read 3 1/2 inch
precision jeweled meter
- ▲ Portable, high-impact case for
rugged work
- ▲ Range: 0 to 1200 RPM
- ▲ All solid state



DELTA PRODUCTS, INC.

P.O. BOX 1147 RE • GRAND JUNCTION, COLORADO 81501

Enclosed is \$ _____ Ship prepaid. Ship C.O.D.

Please send: Dwell Meters @ \$12.95 Mark Tens (Assembled) @ \$44.95
 Tach Meters @ \$14.95 Mark Tens (Delta Kit) @ \$29.95

(12 volt positive or negative ground only)

Specify — Positive Ground Negative Ground 6 or 12 volt

Car Year _____ Make _____

Name _____

Address _____

City/State _____ Zip _____

Circle 109 on reader's service card

75

TUNAVERTER

POLICE-FIRE-AIRCRAFT CALLS
—TUNABILITY — USABILITY — QUALITY —

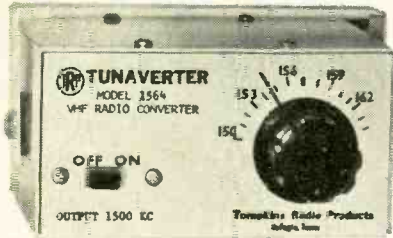

TUNABLE, CALIBRATED solid state converters to change your auto and home radios into excellent, sensitive, selective, calibrated and VHF receivers!

"Your little converters are absolutely tremendous! I would recommend them to anyone!"

Paul English, Canada

- 6-1 reduction tuning!
 - HF—2 gang tuning!
 - VHF—3 gang tuning!
 - FREE 24" conn. coax!
 - Plug into auto radio!
 - American Made!
 - 9 volt btry powered!
 - Size 2 1/4 x 3 1/2 x 4 1/2"
- 2 WEEK MONEY BACK GUARANTEE!

Models for AM & FM

BAND	MODEL	COVERS	OUTPUT	PRICE
Marine	Marine	2.3-3.0 mc	550 kc	\$19.95 ppd
SW & WWV	SWL	9.3-10 mc	550 kc	\$19.95 ppd
CB & 10 M	273	26.9-30 mc	1500 kc	\$29.95 ppd
6 meters	504	50-54 mc	1500 kc	\$29.95 ppd
2 meters	1450	144-150 mc	1500 kc	\$29.95 ppd
Police, fire, & Marine	308	30-38 mc	1500 kc	\$29.95 ppd
	375	37-50 mc	1500 kc	\$29.95 ppd
	1564	150-164 mc	1500 kc	\$29.95 ppd
Aircraft	1828	118-128 mc	1500 kc	\$29.95 ppd
Radiation loop for use with home radios				\$1.25 ppd
Fast AIR MAIL add \$.85 ea.				

Order from:

HERBERT SALCH & CO. Marketing Division of
Tompkins Radio Products
Woodsboro RE6, Texas 78393

Dealers invited

Circle 110 on reader's service card

NEW PRODUCTS continued

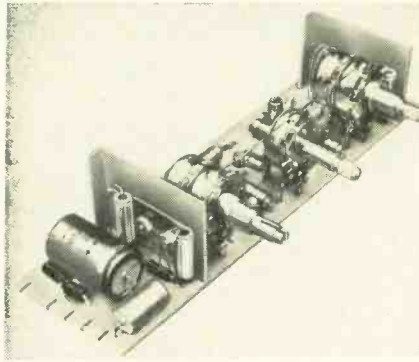

for amps, ceramic and 8-track cartridge preamps. For home-entertainment, ham, PA, and intercoms.—Amperex Electronic Corp.

Circle 61 on reader's service card



2-WAY RADIO, Fleet Courier 30B. 30 W, 25-35 MHz. Self-contained power supply. \$219.50.—Courier Communications, Inc.

Circle 62 on reader's service card

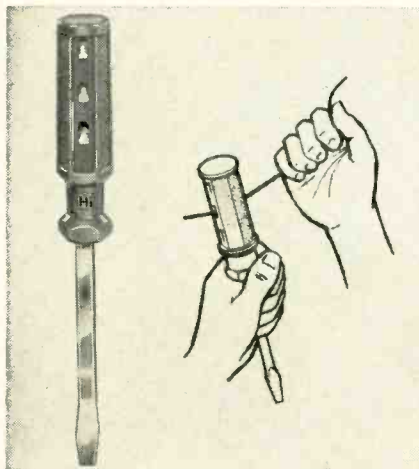

WIRE-STRIPPING SCREWDRIVERS. Sizes marked for stripping Nos. 20 through 12 solid or stranded wire. Cutting blades heat-treated. Square or round blade. \$1.00-\$1.49.—Holub Industries, Inc.

Circle 63 on reader's service card

DIGITAL MEASURING SYSTEM, DMS-3200. Solid-state. Includes the following plug-ins: dc voltmeter, 1-MHz counter, event counter, slave, ohmmeter,



capacitance meter.—Hickok Electrical Instrument Co. END

Circle 64 on reader's service card

NEW—AFC For TV Receivers
Zenith's Training Director analyzes their new afc for TV tuners and explains how to service it in **July RADIO-ELECTRONICS**

NEW LITERATURE

All booklets, catalogs, charts, data sheets and other literature listed here are free for the asking with a Reader's Service number. Turn to the Reader's Service Card facing page 70 and circle the numbers of the items you want. Then detach and mail the card. No postage required!

HI-FI CATALOG, 23 pages, illustrated. Cabinets, components, speakers. Section on choosing speakers and designing enclosures.—Jensen Mfg. Div./The Muter Co.

Circle 65 on reader's service card

CATALOG OF POTS AND RESISTORS, 32 pages. Illustrated. Includes technical specs, dimensional information, off-the-shelf types.—Charostat Mfg. Co.

Circle 66 on reader's service card

MAGNETIC SHIELDING HANDBOOK, B-9236. 32 pages, illustrated. Magnetic shielding for low-frequency applications.—Westinghouse Materials Mfg. Division

Circle 67 on reader's service card

CARTRIDGE REPLACEMENT MANUAL, No. SAC-25. 6,600 cartridges listed. Cross-referenced. Indexed.—Sonotone Corp.

Circle 68 on reader's service card

Write direct to the manufacturers for information on the items listed below:

ELECTRONIC ORGAN BOOKLET. What Is an Electronic Organ. Illustrated, nontechnical. Includes a glossary of terms and tells how to select an organ. 25¢.—Schober Organ Corp.

TRANSISTOR COURSE, Programed instruction. 3 volumes. Includes final examinations and schematics. \$14.25.—General Electric END

WE DON'T CLAIM
OUR ELECTRONIC
IGNITION SYSTEM
IS BEST



OUR CUSTOMERS DO!

WRITE TODAY FOR FREE LITERATURE

JUDSON

RESEARCH AND MFG. CO.
CONSHOHOCKEN, PA., U.S.A.



Circle 111 on reader's service card

Because you've got to SEE it to BELIEVE it
 we will send you a FREE sample!

instant lettering®

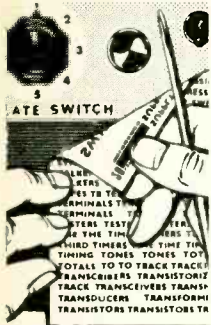

DATAMARK
 — the easy new
 way to label
 your projects!

Just rub over the pre-printed words or symbols with a ballpoint pen and they transfer to any surface — looks like finest printing! Label control panels, meter dials, letter on anything!

LOOK FOR **instant lettering**®

DATAMARK SETS only \$1.25 each
 — at leading electronic distributors

DATAMARK SETS AVAILABLE FOR:

- Amateur Radio, CB
- Audio, Hi-Fi, TV
- Experimenter Home Intercom
- Industrial Test Equipment
- Switch & Dial Markings
- Alphabets & Numerals in

1/8", 1/4" and 1/2"

— each set has black, white, and gold

SEND FOR FREE SAMPLE RE-67

THE DATA CORPORATION
 85 HIGHLAND AVENUE • PASSAIC, N. J. 07055
 Circle 112 on reader's service card

Live Better Electronically With

LAFAYETTE
RADIO ELECTRONICS

FREE!



LAFAYETTE

1967
 Catalog
 670

NOW
 OFF PRESS
 BETTER THAN
 EVER

Featuring Everything
 in Electronics for

- HOME • INDUSTRY • LABORATORY
- from the
 "World's Hi-Fi & Electronics Center"

- Stereo Hi-Fi • Citizens Band • Ham Gear
- Tape Recorders • Test Equipment • TV and Radio Tubes and Parts • Cameras • Auto Accessories • Musical Instruments • Tools • Books

LAFAYETTE Radio ELECTRONICS
 Dept. JF-7 P.O. Box 10
 Syosset, L.I., N.Y. 11791

Name _____
 Address _____
 City _____
 State _____ Zip _____
 (Please Give Your Zip Code No.)

Circle 113 on reader's service card

Build an IC Sound Relay

circuit board. There is no reason for not making the whole device smaller.

A 45-ohm intercom speaker works very well as a microphone. A speaker with an 8-ohm or 3.2-ohm voice coil can be used with a matching transformer. In that case, a secondary of 2,000 or 2,500 ohms will be satisfactory. High-impedance microphones can be matched with a transformer also. A good one to try is a transistor audio driver transformer with about 10:1 ratio for dynamic mikes with 50,000 ohms impedance. Crystal mikes will need a 50:1 or even 100:1 ratio. Impedance matching is not too critical for voice-operated relay tripping.

Note that the input transformer is coupled through capacitors C4 and C5. Polarity is correct as shown in the diagram. Both sides of the transformer *do* go to the *negative* sides of the capacitors. These capacitors are necessary to avoid disturbing the internal biasing of the device. If you check with your vtvm, you will find that the input terminals are slightly above ground. Westinghouse engineers suggest not using any external components that will alter this bias voltage.

C2 and C3 are 10- μ F decoupling capacitors. Solid tantalums rated at 20 volts were used in the prototype, but any small low-voltage electrolytics should work equally well. Just be sure they are good before you use them.

Gain is controlled by a miniature transistor-radio volume control (R3). It can be bolted to the board that holds the other components. It will require adjusting for maximum sensitivity in

different locations because background noise level varies. It can be turned up as battery voltage drops. Maximum gain is with pins 4 and 8 shorted (minimum resistance).

Output transformer T2 is a special modulation transformer for a 27-MHz CB transceiver (available from Lafayette Radio Electronics Corp., 111 Jericho Turnpike, Syosset, N. Y. 11791). The 3,000-ohm winding goes to the relay circuit, and the 8-ohm winding can feed a pair of low-impedance headphones for monitoring or testing.

The relay is made especially for radio control in model airplanes or boats and is available from any supplier of radio-control equipment. The contacts will carry 500 mA, which will do to start and stop a miniature tape recorder. If heavier currents are to be interrupted, or if higher voltages than 9 or 12 are to be used, an additional relay should be used in cascade to handle the extra load.

Working with the WC 183G

Handle an IC with tweezers! The most convenient way to mount one is probably with a drop of cement. (Goodyear Pliobond cement is fine, and available at local Goodyear tire stores and many hardware stores.) Put one drop on the Bakelite board and another drop on the back of the WC 183G. Allow both to dry for a few minutes until the cement is tacky, then carefully and firmly press the IC against the board.

Carefully straighten and press each lead against the circuit board so that all are held down by the cement. Leads are

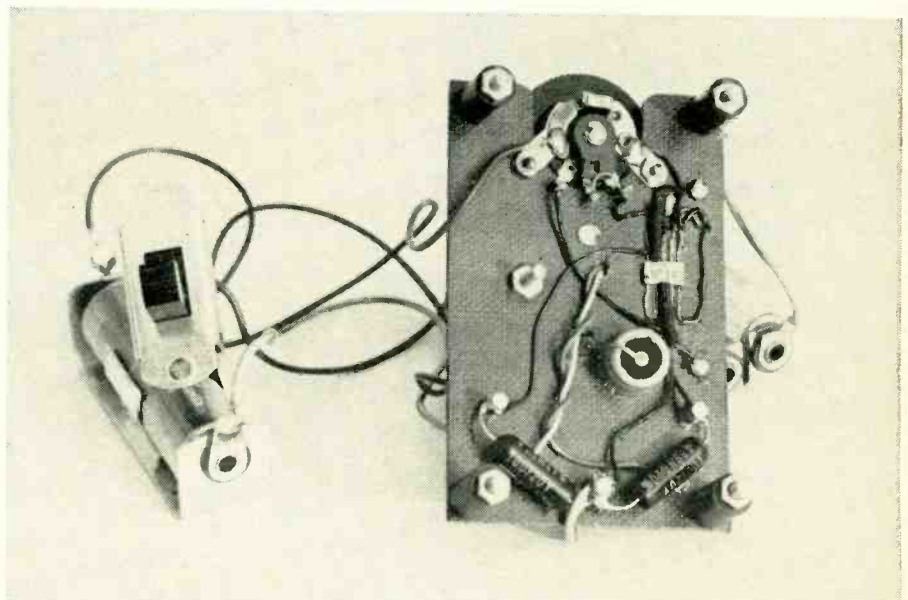

The other side of the board. Can you find the IC? It's the flat thing with the marking "WC183" barely visible—on the right side of the board just above center.

identified by the black dot next to pin lead No. 1. Use phono pickup arm wire for connections. Use the smallest soldering pencil when soldering IC leads, get it *hot* and work fast.

Use nothing but the finest grade of rosin-core solder. First, tin all leads to be joined; then sweat them together with a quick dab of the hot iron. A clamp-on heat sink is handy for holding wires in place while soldering. Practice on some scrap pieces of wire until you can make a good clean sweated joint fast. Just a quick touch of a hot iron is all you need. After all the connections are soldered to the WC 183G, coat it with more cement to anchor everything firmly.

Connect the battery with the right polarity! IC's cost money. If you goof, you pay! Check all connections *before* you install the batteries.

Testing and adjusting

Connect your vtvm across C1 and set it to the 1.5-volt dc range. Turn S1 off. Turn S2 on and take a no-signal voltage reading across C1 with R1 and R2 not yet in the circuit. This reading should be less than 0.1 volt. Now turn on S1 and advance the gain control. You will reach a point where the relay trips on background noise. With the speaker or microphone disconnected, you should be able to trip the relay by bringing your hand close to terminal 3 or 9, without actually touching either of them. (Without a mike, this device makes a good "touch" relay.)

Observe the voltage levels at which the relay pulls in and drops out. Pull-in should occur at 0.28 or 0.3 volt, and dropout at 0.20 to 0.22. If necessary, carefully adjust relay spring tension to set the pull-in point. Remember that increasing the spring tension will also shorten the time cycle. You can omit R2 if the background-signal voltage across C1 falls below the relay dropout point without it. This will depend on several factors and can be determined only by experiment.

If the background-noise level is high enough to trip the relay with R2 out of the circuit, connect a variable resistor across C1 and reduce the resistance gradually while observing the result with the vtvm. Choose a fixed resistor closest to the resistance that will hold the voltage across C1 to below the relay dropout point of about 0.2 volt. R2 should be from 10 to 50K ohms. If it is less than 10K, try a different transistor and use a rolloff capacitor across pins 5 and 7 of the IC.

Any resistance across C1 acts as a bleeder and reduces the sensitivity somewhat. Adjust R1 for the required holding period. If you need an adjusta-

ble time delay, use a 50K pot and series limiting resistor for R1 (Fig. 2). If you do not need the variable delay, make a temporary hookup like Fig. 2 to determine the value you want and then substitute the closest value in a fixed resistor. R1 is not shown in the photos.

When checking and selecting components, choose a transistor with low leakage and a diode with a high forward-to-back resistance ratio. C1 must also have low leakage, and it is desirable to form it by connecting it overnight across a 1.5-volt battery. (Observe polarity!)

To avoid talking yourself hoarse while making adjustments, connect a small speaker to your audio generator and use it as a sound source. This will give you a variable source of low-level audio. Keep the frequency in the range of normal speech, under 3,000 Hz. If you have trouble with high-frequency background noise, install a rolloff capacitor (.05 μ F or less) across IC pins 5 and 7. This capacitor is not shown on the wiring diagram; it will not usually be required, and it reduces sensitivity somewhat.

By connecting a pair of headphones across the 8-ohm secondary of T, you can monitor the signal and check for noise, motorboating, hiss, hum and lack of response from the amplifier. The headphone load will affect relay operation, so disconnect the phones while setting up the timing and using the sound relay. You can use the 8-ohm output to drive a miniature speaker also.

To make a recording with the sound relay, set the tape recorder on RECORD and adjust its volume correctly. Everything must be set ready to go. You will probably have to cut one of the battery leads to your recorder and run a pair of wires to the sound-powered relay contacts. The regular switch in the recorder will then be left on all the time. Add a shorting switch across the sound-relay contacts to bypass them when the sound relay is not in use.

You may also want to install a switch to stop the recorder when the tape is all used up. On recorders in which the on-off switch is not a part of the record-playback transfer, all you will need to do is to hook the sound-relay contacts across the power switch. If you do that, include another switch in series to disable the sound relay in case the points should stick. This will also enable you to stop the recorder without disconnecting the sound relay.

All recorders take a moment to get up to full speed. Experience will tell you how to work with yours. You may need to say "uh" into the mike while the recorder comes up to speed. END

BIG CATALOG

World's "BEST BUYS" in GOVT. SURPLUS Electronic Equipment

BC-603 RECEIVER—F.M. 20—27.9 MC. Continuous tuning and 10 preset push button channel selector. With sensitivity squelch & volume controls, 2 watt output to self contained speaker, one microvolt sensitivity, 2.65 KC I.F. 10 Tubes: 3/6AC7, 1/6J5, 2/12SG7, 2/6SL7, 1/6H6, & 1/6V6GT. Voltage required 12/24 volts for filaments, 220 VDC @ 80 MA for high volt. Size: 11½ x 6¼ x 12½". Wt.: 35 lbs. **\$32.95**

BC-603 RECEIVER, CONVERTED TO 30-45 MC. U: \$44.95
AC POWER SUPPLY f/BC-603: Wired \$14.95 • Kit \$10.00
DM-34 Dynamotor for 12 VDC operation: New: \$ 4.95
 Prices F.O.B. Lima, O.—25% Deposit on COD's—BIG CATALOG—Send 25¢, Receive 50¢ credit on your order!

FAIR RADIO SALES
 1016 E. EUREKA • Box 1105 • LIMA, OHIO • 45802

How To Check Your Test Instruments

Are your test instruments reliable? A member of EICO's engineering staff gives step-by-step details on checking and recalibrating your test equipment in

July RADIO-ELECTRONICS



PERMOFLUX . . . ANNOUNCES A BRAND NEW HEADPHONE . . . the "HM" SERIES

The entire audible spectrum, from the resounding bass smoothly thru the soothing middle ranges to the clear tingling highs, is awaiting you in the miniature earspeakers, as these headphones comfortably engulf your ears. Feather-lite in weight, fully adjustable, the superior Permoflux quality is now available at popular prices. A wide selection of impedances.

All ear speakers are fully warranted for life.

STANDARD OF THE WORLD

Permoflux Corp.

P.O. Box 6364, Dept. RE 6
 GLENDALE, CALIFORNIA

Circle 114 on reader's service card

Use this 8-volume transistor library for 10 days, free!

(You can save \$5.00 if you decide to keep it.)



This complete 8-volume library on transistors covers every facet of transistor knowledge and theory from basics right through to advanced techniques and devices that you can build, using transistors for practical and experimental projects. These 8 books contain almost everything known about transistors and will give you the know-how to keep your future secure in electronics. More than 1,300 pages packed with the latest information on transistor theory and practice in this complete transistor library offers you the opportunity for a more secure future in electronics. If you want to stay on top of an exciting, highly paid future in electronics, you've got to keep up with modern technology.

Actually the library contains 2 sections: a basic library of 5 books containing *Basic Transistor Course*, *Getting Started with Transistors*, *Transistor Circuits*, *Transistor Techniques*, and *Transistor Projects*; an advanced transistor library, made up of *How to Fix Transistor Radios and Printed Circuits*, volumes 1 and 2, by famous author Leonard Lane, and *New Skill-Building Transistor Projects and Experiments*. This complete 8-volume library retails for \$24.05. Try them for 10 days... see if you don't agree that this is the most complete, easy-to-use and understand treatment of transistors you have ever read. If you decide to keep them, pay only \$19.05.

Save an extra \$1.00. If you accept the complete, 8-volume transistor library and send payment with your order, you save us billing costs. We will pass this saving on to you. Take \$1.00 off the already low price of \$19.05. Your cost \$18.05 (tax deductible for business purposes). Your total saving \$6.00. Same return privilege applies.



BASIC TRANSISTOR COURSE. By Paul Rodger Kenian. Provides a complete background in transistors, what they are, how they work, how they behave with resistors, capacitors, coils and batteries. In clear, practical language, the author starts with a simple treatment of semiconductor physics and proceeds in logical steps to semiconductor diodes, transistor triodes, transistor characteristics, audio amplifiers, detectors, AGC circuits, IF amplifiers, transistor types, and circuit analysis. 224 pages packed with illustrations and review questions.

GETTING STARTED WITH TRANSISTORS. By Louis E. Garner, Jr. Transistor know-how begins with this volume. Shows how transistors began, how to read electronic diagrams, how transistors work, facts on oscillator types, diodes, phototransistors, rectifiers, transistor ratings, testing transistors. Excellent text, diagrams and photographs carry you through every phase of transistors to give you a complete grasp of the subject. 160 pages by an expert in the field.

TRANSISTOR CIRCUITS. By Rufus P. Turner. Application of the transistor to electronic circuitry. Here, in one complete volume is a collection of practical transistor circuits, each of which has been tested by the author in his own laboratory to save you hours of design time: as building blocks with values already worked out, or you may modify component values to obtain different results. Chapters include amplifiers, oscillators, power supplies, radio receivers, triggers and switches, control devices, test instruments and more. 160 fact-packed pages.

TRANSISTOR PROJECTS. By Editors of Radio-Electronics. Whether you work with transistors as a hobby or as a profession, and whether your approach is at the design or the practical level, your job will become easier (or your hobby more enjoyable) the more you learn about the subject. Here are projects to build your know-how: building transistor radios, instruments and accessories, special projects like transistor lamp control, electronic compass, remote transistor ear, "the snitcher," portable power supply, and much, much more. 160 pages.

TRANSISTOR TECHNIQUES. By Editors of Radio-Electronics. Gives scores of hints on how to use transistors to best advantage. Keeps theory and math to a minimum and concentrates on practical know-how. Covers protecting transistors, testing, transistor performance, measurements, oscillators and triggers, transistor dc transformer, auto-light control, geiger counter. Perfect book for the man who already knows some transistor theory and is ready to improve his practical handling of transistor devices. 96 pages.

HOW TO FIX TRANSISTOR RADIOS & PRINTED CIRCUITS, VOL. I & II. By Leonard C. Lane. A 2-volume course that shows how to spot trouble in the audio section, pinpoint speaker and earphone circuit defects, check distortion in the audio amplifier, locate front-end troubles, eliminate printed-circuit board pitfalls, and work more effectively with signal generator, vtvm, scope and isolation probe. Hundreds of illustrations . . . practical tips to save shop time, to lessen servicing trial and error, to find and fix any trouble with professional know-how. 2 volumes, 320 pages.

NEW SKILL-BUILDING TRANSISTOR PROJECTS AND EXPERIMENTS. By Louis E. Garner, Jr. This unusual handbook helps you discover everything about transistors by actually doing things with transistors. Shows how to conduct experiments to gain new facts and prove key points. You'll assemble your own circuits, make your own tests, draw your own conclusions based on the knowledge you've acquired. Projects include: headphone amplifier, hi-fi preamplifier, power megaphone, two-station intercom, rain alarm plus other practical projects and experiments. 192 value-packed pages.

Complete Transistor Library

All 8 volumes . . . more than 1,300 pages packed with all the latest information on transistor theory and practice. Books by the most famous electronics writers in the country. Hundreds of illustrations make this difficult technology easy to understand. An excellent foundation for a fine future in electronics. Retail price \$24.05. Your price only \$19.05 (\$18.05 if you enclose payment with your order). Tax deductible for business purposes.

Basic Transistor Library

5 volumes . . . 800 pages of vital transistor knowledge that you need to keep ahead of electronics today. All the information needed to obtain a solid foundation of transistor theory and practice and a requisite for further study. Hundreds of schematics . . . block diagrams and photographs to make this difficult subject easy to understand. List price \$15.20. Save \$3.55. Order for only \$11.65 (tax deductible for business purposes).

Advanced Transistor Library

3 volumes . . . 512 pages packed with the newest data on transistors; including new projects and experiments you can build. Complete course on repair of transistor radios and printed circuits. Many illustrations to clarify and simplify text. Includes *How to Fix Transistor Radios and Printed Circuits*, volumes I & II, and *New Skill-Building Transistor Projects & Experiments*. Retail price \$8.85. Save \$1.45. Only \$7.40 (tax deductible for business purposes).

SAVE MOST ON THE COMPLETE, 8-VOLUME TRANSISTOR LIBRARY

**SAVE AN EXTRA
\$1.00**

Send payment with your order for the complete, 8-volume transistor library. Deduct an extra \$1.00 off the already low price of \$19.05. Same return privilege applies.

**GERNSBACK LIBRARY INC., DEPT. RE67
154 West 14th Street, New York, N. Y. 10011**

Send me the following Transistor Library for free 10-day trial:

- Complete Transistor Library of 8 books \$19.05
(\$18.05 if you pre-pay)
- Basic Transistor Library (5 books) \$11.65
(You save \$3.55)
- Advanced Transistor Library (3 books) \$ 7.40
(You save \$1.45)

New York residents please add sales tax.

Enclosed \$ _____ Bill me

Name _____

Address _____

City _____ State _____ Zip _____

THIS OFFER GOOD ONLY IN THE U. S. AND CANADA

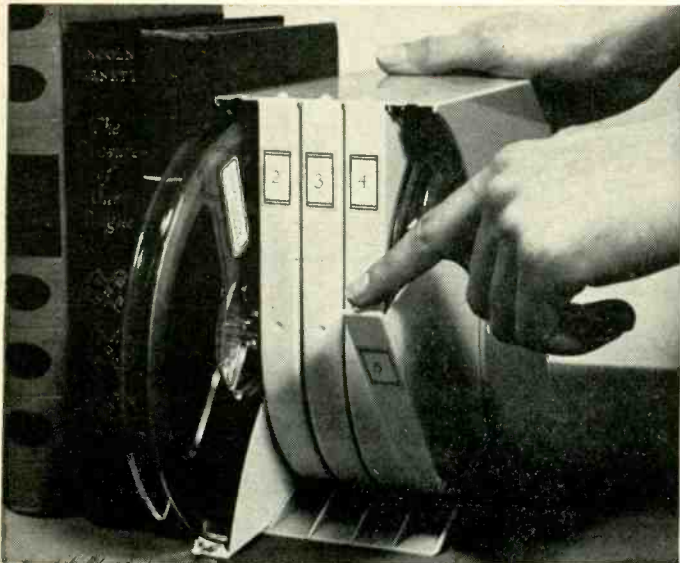

A clever tape file

Stores 5 reels in one sturdy plastic case with swing-out compartments. Protects these valuable tapes, keeps them handy, indexed and orderly. Stacks horizontally or vertically, comes in three sizes (for 3-, 5-, 7- inch reels). Handsome two-tone beige. (A neat 8-mm film file too!)

3": \$2.99
5": \$4.45
7": \$4.95
(all prices less reels)



Available through your local distributor, or write to:
RYE INDUSTRIES INC.
128 Spencer Place, Mamaroneck, N.Y. 10543
Circle 115 on reader's service card

LET BROWNING SHOW YOU HOW TO MAKE GOOD MONEY SELLING THE BEST CITIZENS BAND RADIO EQUIPMENT ON THE MARKET.

Write for full details on how you can cash in on the increasing demand and rising sales of Browning CB radio equipment. Here are some of the advantages of operating a Franchised Browning Sales and Service Center.

- ✓ Exclusive territory — protected sales and profit.
- ✓ No competition from large mail-order distributors.
- ✓ Complete sales aids, catalogs, plus continuous national advertising by Browning.
- ✓ Technical assistance from the factory whenever you may need it.
- ✓ In-warranty service backed by Browning.
- ✓ Substantial parts discount for your servicing needs.
- ✓ Prestige of selling the industry's finest equipment... the Eagle base station, the Raven mobile unit.

MANY TERRITORIES AVAILABLE.
WRITE TODAY:
browning
LABORATORIES, INC.

DEPT. E6, 1269 UNION AVENUE, LACONIA, NEW HAMPSHIRE

Circle 116 on reader's service card

R-E PUZZLER

Based on electronic terminology, this only-across-word puzzle should be fairly easy. Each word is connected to the word above and below by one letter. You'll find the answer to last month's puzzle on page 91.

- 1 Device used to measure small values of capacitance.
- 2 Type of cathode-ray tube used in scanning-converter applications.
- 3 Radio circuit damped sufficiently to prevent oscillation or resonance.
- 4 Combination of two dipoles.
- 5 Atmospheric noise.
- 6 Alkali metal used in photo-tube cathodes.
- 7 Flow of electromagnetic radiation concentrated in a desired direction.
- 8 Package of components which provides complete function.
- 9 Circuit used to prevent excessive correction in a feedback control system.
- 10 Unvarying or fixed values.
- 11 Circuit serving simultaneously as oscillator and heterodyne detector.
- 12 Electrical power.
- 13 Conductive graphite coating used in and on cathode-ray tubes.
- 14 Self-quenching oscillator in which detection occurs in grid circuit.
- 15 Amplifier circuit used in early tuned-radio-frequency receivers.
- 16 Eight-electrode tube.
- 17 Color of band on resistor to represent four.
- 18 Instrument to measure reciprocal of frequency.
- 19 Electronic circuit for altering frequency response of an amplifier.
- 20 Pertaining to the gradual destructive force on metal by atmosphere, etc.
- 21 Measured value which expresses performance.
- 22 Line which comes nearer and nearer to a given curve but never touches.
- 23 Pictorial presentation of relation between two or more variables.
- 24 A TV camera tube.
- 25 Pertaining to a system using extremely small electronic parts.

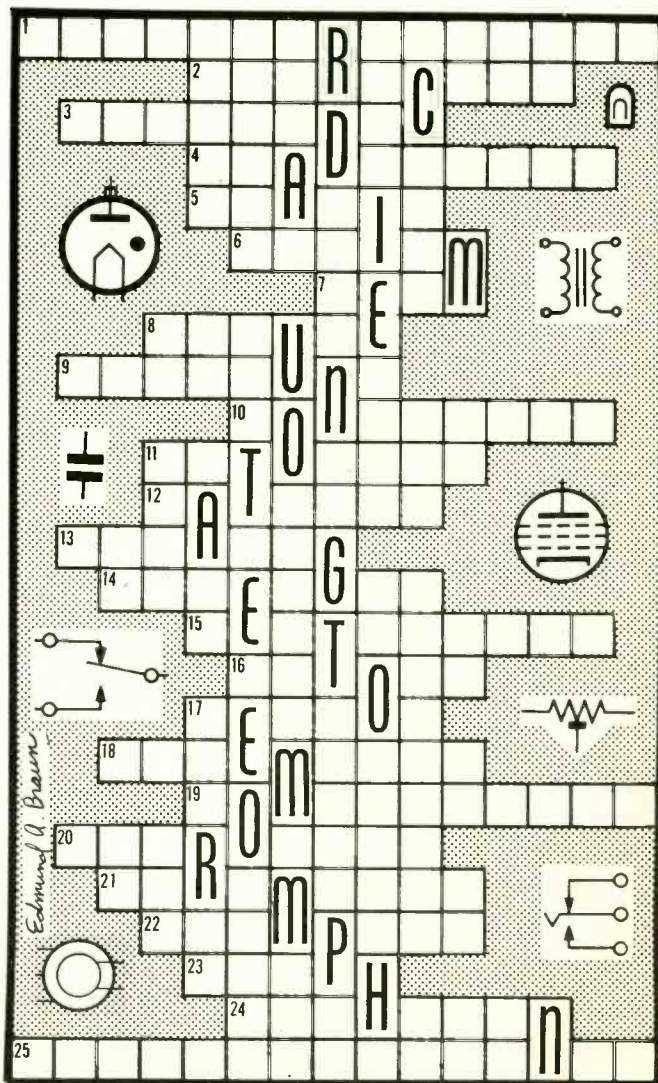

Solution next month

Exhibitors at Consumer Electronics Show

For more details of the Show, see page 57.

- | | |
|--|--|
| Adler Manufacturing Corp. | Masterwork Audio Products |
| Admiral Corp. | Matsushita Electric Corp. of America |
| American Audion Corp. | Mercury Record Corp. |
| American Geloso Electronics, Inc. | Midland International Corp. |
| Ampex Corp. | Morse Industries |
| Andrea Radio Corp. | Motorola, Inc. |
| Aristo Tone Electronics, Inc. | Muntz Stereo-Pak, Inc. |
| Artic Import Company, Inc. | New York Transistor Corp. |
| Arvin Industries, Inc. | North American Foreign Trading Corp. |
| BSR (USA) Limited | North American Philips Co., Inc. |
| Bell & Howell Co. | Olympic Radio & Television Sales Corp. |
| Bogen Communications Div. | Packard Bell Sales |
| Borg-Warner Corp. | Peerless Telerad Inc. |
| Bulova Watch Co., Inc. | Philco-Ford Corp. |
| Califone-Roberts Electronics Div. | Phillips Audio Inc. |
| Capitol Records, Inc. | Pilot Radio Inc. |
| Channel Master Corp. | RCA Sales Corp. |
| Clairtone Electronic Corp. | Realtone Electronics |
| Claricon Products | Ross Electronics Corp. |
| Commodore Import Corp. | S.C.A.R.T. (Syndicat des Constructeurs d'Appareils Radiorecepteurs et Televisseurs |
| Concertone Division | Sansui Electronics Corp. |
| Concord Electronics Corp. | H. H. Scott, Inc. |
| Consolidated Merchandising Corp. | The Seeburg Corp. |
| Craig Panorama, Inc. | Selectron International Co., Inc. |
| Delmonico International Corp. | Setchell Carlson, Inc. |
| Dynavox Electronics Corp. | Sharp Electronics Corp. |
| Electra Radio Corp. | Shibaden Corp. of America |
| Elgin Radio Division | Sony Corp. of America |
| Fanon Electronic Industries, Inc. | Standard Radio Corp. |
| Fisher Radio Corp. | Sterling Hi Fidelity Inc. |
| General Electric Co. | Superex Electronics Corp. |
| Consulate General of the Federal Republic of Germany | Superscope, Inc. |
| Global Import & Export Inc. | Sylvania Electric Prods. Inc. |
| The Gregory Amplifier Corp. | Symphonic Radio & Electronic Corp. |
| Grundig-Triumph-Adler Sales Corp. | TRAC Corp. of America |
| Harman-Kardon, Inc. | Telefunken Sales Corp. |
| Hitachi Sales Corp. | Telepro Industries, Inc. |
| Hoffman Electronics Corp. | Tele-Tone Co., Inc. |
| Industrial Suppliers Co. | Telex Acoustics, Inc. |
| Jensen Manufacturing Div. | Tenna Corp. |
| KLH Research & Development Corp. | Topp Import & Export, Inc. |
| Kaysons International | Toshiba America, Inc. |
| Lear Jet Industries, Inc. | Transworld, Inc. |
| Lion Electronics Corp. | Universal Tapedex Corp. |
| Lloyd's Electronics Corp. | Viscount Electronics Div. |
| 3M Company | Velvetone Enterprises Inc. |
| M-G-M Playtape | Viking of Minneapolis, Inc. |
| Magnecord | Waters Conley Co., Inc. |
| Major Electronics Corp. | Webcor, Inc. |
| Martel Electronic Sales, Inc. | Westinghouse Electric Corp. |
| Master-Craft Electronics Corp. | Zenith Sales Corp. |

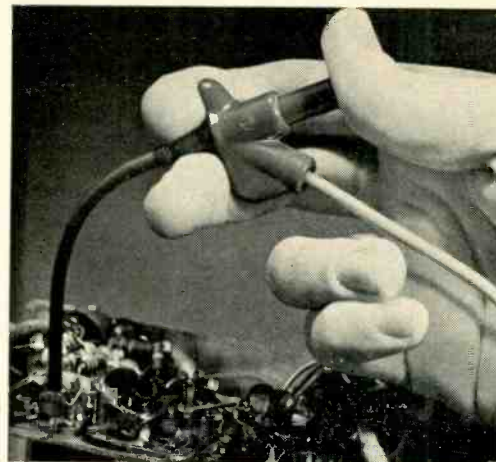

Clever Kleps 30

Push the plunger. A spring-steel forked tongue spreads out. Like this  Hang it onto a wire or terminal, let go the plunger, and Kleps 30 holds tight. Bend it, pull it, let it carry dc, sine waves, pulses to 5,000 volts peak. Not a chance of a short. The other end takes a banana plug or a bare wire test lead. Slip on a bit of shield braid to make a shielded probe. What more could you want in a test probe?



Available through your local distributor, or write to:

RYE INDUSTRIES INC.
128 Spencer Place, Mamaroneck, N.Y. 10543
Circle 117 on reader's service card

\$147

GAS WELDING TORCH



Uses **OXYGEN** and **LP GAS**

- Completely self-contained.
- Produces 5000° pin-point flame.
- Welds, brazes, solders.
- Hundreds of lightweight uses.
- Suggested list - \$19.95.

GET COMPLETE DETAILS AT MOST INDUSTRIAL DISTRIBUTORS, OR WRITE TO MICROFLAME, INC.



MICROFLAME, INC.

7800 COMPUTER AVENUE
MINNEAPOLIS, MINNESOTA 55424



HOME WORKSHOP



TECHNICIANS



REPAIR AND SERVICE SHOPS

Circle 118 on reader's service card

Coming Next Month In Our Big July Test Instruments Issue

Features seven build-it-yourself precision test instruments plus articles explaining how to use, check, recalibrate and get the best out of your instruments.

NEW—AFC For TV Receivers

Zenith's Training Director analyzes their new afc for TV tuners and explains how to service it in

July RADIO-ELECTRONICS

JUST OUT!

THE Transistor Book of the Year!

1967 EDITION only \$2.95

over 6,000 American and foreign transistors, their specifications and over 15,000 substitutions.

ALSO Includes these Universal Replacements:

DS-Series RCA-SK Series
GE-10 Series Semitronics
IR-TR Series Workman

at your Parts Suppliers now, or order below:

Enclosed please find \$ _____ (plus 10c postage for each book) for the following:

- Send FREE Catalog
- Transistor Specifications & Substitution Handbook.....\$2.95
- Diode Select-A-Spec.....\$2.95
- Transistor Select-A-Spec.....\$3.95
- Selected Semiconductor Circuits.....\$1.25
- Semiconductor Circuits Handbook Vol. I.....\$2.95
- Semiconductor Circuits Handbook Vol. II.....\$1.95
- Receiving Tube Specifications and Substitutions.....\$1.95
- Principles of Electronic Oscillators.....\$1.95
- Principles of RF Power Amplifiers.....\$1.95
- Principles of Transmission Lines.....\$1.95
- Antenna Principles and Wave Propagation.....\$2.95

TECHPRESS, INC.
Brownsville, Indiana 46112

Name _____
Address _____
City and State _____

Circle 135 on reader's service card

TECHNOTES

WHERE HUM COMES FROM

Silvertone's model 6023 AM-FM receiver sometimes develops hum in the FM function. It's caused by a high-resistance solder joint at the power-supply input filter. Although the printed circuit may appear to be in perfect condition, trouble shows up at the high frequencies used in FM, where the bad connection has a high impedance for rf.

To eliminate the hum, scrape the resist paint from around the filter lead and resolder. Use no more heat than necessary, for otherwise you may loosen the foil from the board, and this could cause trouble later.—Noble Travis

POPPING 35W4 TUBES

A Motorola model 56CD radio come in with a dead 35W4 tube. A new tube was inserted and it lit up like a Christmas tree and then went out. Suspecting a short in the B+ circuit, I applied an ohmmeter to the circuit. The resistance was not far off, so another 35W4 tube was installed.

Pop! went another 35W4 tube. The circuit was checked again and nothing showed up. Another 35W4 was inserted and the radio played for one hour before going dead again.

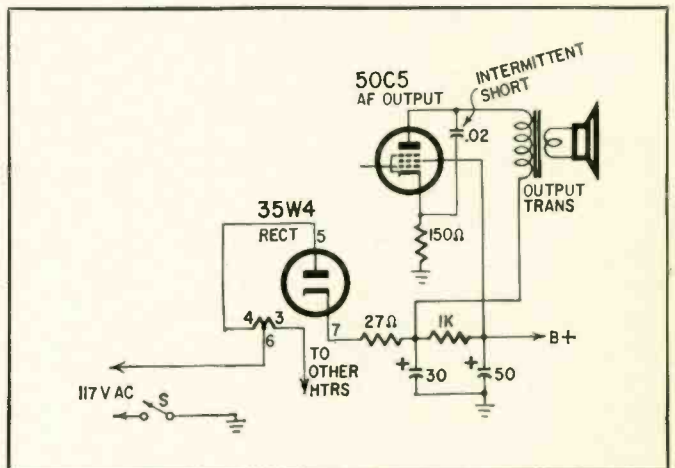

Further checking revealed a 150-ohm short in the B+ circuit at the plate of the 50C5 output tube. The .02-μF capacitor from plate to cathode was shorted. A new one was installed and the radio played like a new one. Undoubtedly, this capacitor was intermittently shorting and placing a 150-ohm load across the cathode of the 35W4.

—Homer L. Davidson

AUTO RADIO INTERFERENCE

Improperly grounded two-speed electric windshield wipers at times interfere with radio reception. This interference can be eliminated by connecting a length of No. 14 stranded wire between the wiper-motor switch plate and the motor mounting plate.—H. Muller

ZENITH 25MC36 COLOR CHASSIS

The symptom was a rapid vertical roll followed by a collapsing raster. The raster would then fill out and the cycle of events would repeat at a rapid rate. The trouble was traced to a defective vertical integrator network (see diagram) in the feedback loop between the plate of the vertical output

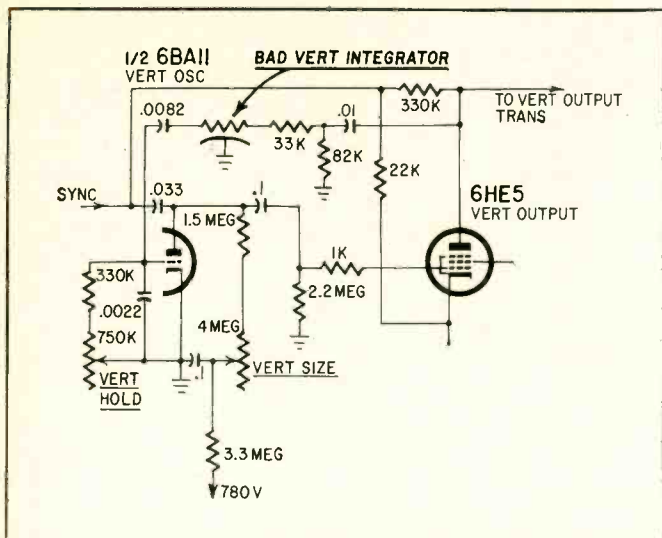

stage and the grid of the vertical amplifier. The correct replacement is Zenith part No. 87-5.

Another frequent trouble in this chassis is intermittent color. Color can be made to come and go by tapping the chassis. If the trouble seems to be around the demodulator tubes, check the injection transformer. We've run across a number of these where the wires to the terminals inside the can are too long and touch the can or adjacent terminals. To eliminate the problem, dress the wires down closer to the terminals, and resolder.—*Jim Wilhelm*

ADMIRAL REPLACEMENT TRANSISTORS

You must use transistors with the same beta when replacing output power amplifiers or complementary-pair drivers. The beta is indicated by a paint mark, a letter or a number following the Admiral part number. Transistors are matched only when the part number, beta code and manufacturer are the same. You cannot match them if any one of these three factors differ. The manufacturer is indicated by a trademark, EIA code number or initials.—*Admiral Service News Letter* END

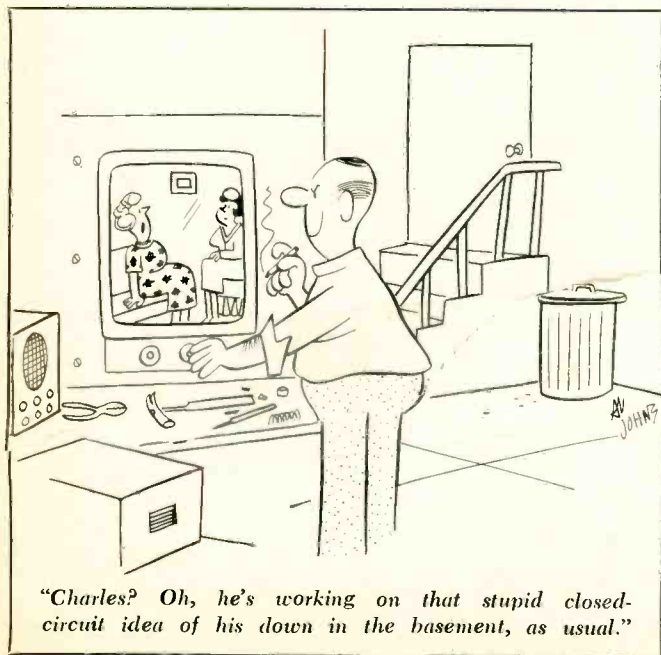

"Charles? Oh, he's working on that stupid closed-circuit idea of his down in the basement, as usual."

Swingin'
Combo
for
Top
Performance!



NEW SENCORE SM112B SERVICE MASTER VTVM/VOM

Here it is—the third generation of Sencore's famous Service Master—the two-in-one professional instrument that saves your time, speeds your service work, puts extra profits in your pocket.

- Just one function switch, one range switch and one probe provide all functions of VTVM and VOM.
- Voltage, current and resistance in 33 ranges — for accurate measurements anywhere, anytime.
- VTVM operates from 115v AC for precise bench or lab work; battery powered VOM gives you a 5000 ohms per volt meter.
- Lighted arrows automatically indicate VTVM scales.
- Large, easy-to-read 6-inch two percent meter covers all measurements.
- Handsome new styling in tough, vinyl-clad steel case.
- Optional high voltage probe attaches for measuring up to 30,000 volts DC.

So why use two when one will do — the new Sencore SM112B. Truly professional quality, and still only **\$89.95**
High Voltage Probe HP118 \$7.95

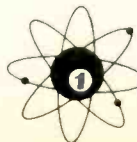

SENCORE

NO. 1 MANUFACTURER OF ELECTRONIC MAINTENANCE EQUIPMENT

426 SOUTH WESTGATE DRIVE, ADDISON, ILLINOIS 60101

rapid start. The 3BN2 is generally interchangeable with the 3AT2 but has a slightly higher voltage drop.

The 3CN3 is a heater-cathode type diode designed as a high-voltage rectifier. It features a special cathode coating to minimize arcing.

The 6LC6 low-current, high-voltage beam triode is an octal version of the 6EF4. Design-maximum ratings of the 6LC6 are identical to the 6EF4 and include a dc plate voltage rating of 27 kV, dc maximum plate current rating of 1.6 mA and plate dissipation rating of 40 watts.

Additional information on these tubes can be obtained from General Electric Co., 316 E. 9th St., Owensboro, Ky. 42301.

VOLTAGE-REGULATOR MODULES

The BN-4008 and BN-4009 are the newest additions to the Bendix line of dc regulator modules. These 5-volt units are packaged in high-dome TO-3 cases and are rated at $\pm 1\%$ regulation from minimum to maximum load. They weigh approximately 0.5 oz and are designed to replace many of the plug-in and hand-wired units now in use.

The modules fit sockets and heat sinks designed for TO-3 cases. The BN-4008 is a series-type 5-volt regulator. Input voltage range is 9-30 V, maximum

output current is 1 A, maximum power dissipation (case 25°C) 25 W, output regulation 2% for 20% change in input voltage. The diagram shows the schematic of the BN-4008 and its application.

The BN-4009 is a shunt-type 5-volt regulator. Maximum and minimum input current ratings are 1 A and 30 mA; dissipation 25 W; load regulation (no load to full load) $\pm 1\%$. END

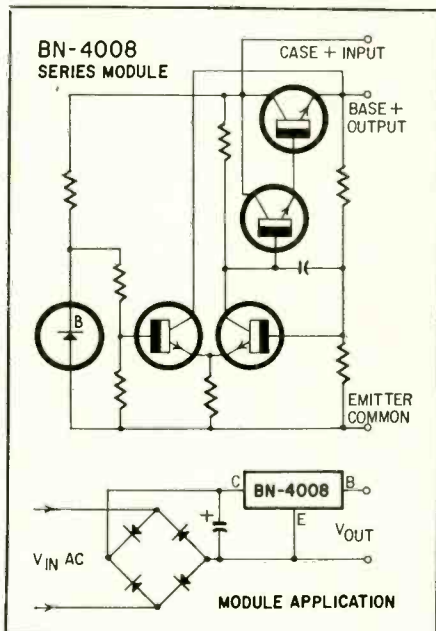

Enjoy the "music-only" programs
now available on the FM broadcast
band from coast to coast.

- NO COMMERCIALS •
- NO INTERRUPTIONS •

It's easy! Just plug Music Associated's Sub Carrier Detector into multiplex jack of your FM tuner or easily wire into discriminator. Tune through your FM dial and hear programs of continuous commercial-free music you are now missing. The Detector, self-powered and with electronic mute for quieting between selections, permits reception of popular background music programs no longer sent by wire but transmitted as hidden programs on the FM broadcast band from coast to coast. Use with any FM tuner. Size: 5 1/2" x 9". Shipping weight approx. 7 lbs.

KIT \$4950
(with pre-tuned coils, no alignment necessary)

WIRED \$7500 (Covers extra \$4.95 ea.)

Current list of FM Broadcast stations with SCA authorization \$1.00

MUSIC ASSOCIATED
65 Glenwood Road, Upper Montclair, N. J.
Phone: (201)-744-3387 07043

Circle 139 on reader's service card

CANADIANS: Ordering is easy . . . we do the paperwork . . . try a small order

SARKES TARZIAN TV TUNER 41mc

Latest Compact Model—good for all 41 mc TV's.
BRAND NEW—MONEY BACK GUARANTEE

Best TUNER "SARKES TARZIAN" ever made—last word for stability, definition & smoothness of operation. An opportunity—to improve and bring your TV Receiver up-to-date.

COMPLETE with Tubes & Schematic . . . \$7.95

HIGHWAVE AM-FM PORTABLE RADIO

Elegance in Ebony & Chrome
14 Transistors — A Powerhouse of Quality Reception with AFC
Operates on 4 "C" Cells
22" Telescoping FM Antenna & Personal Listening Attachment
Money refund — if not better than any Known Brand selling for even twice the price
8" x 5 1/4" x 2 1/4" — 4 lbs

COMPLETE . . . \$19.50

IBM COMPUTER SECTIONS

8 assorted Units we sell for \$1 are loaded with over 150 valuable parts.

Incl. — Transistors
Condensers, Resistors, Heat Sinks, Diodes, Etc.

8 for \$1
100 for \$10

- | | | | |
|---|---|---|---|
| <input type="checkbox"/> 1000—ASST. HARDWARE KIT \$1
screws, nuts, washers, rivets, etc. | <input type="checkbox"/> 300 — ASSORTED HEX NUTS \$1
2/56, 4/40, 5/40, 6/32, 8/32 . . . | <input type="checkbox"/> 250—ASST. SOLDERING LUGS \$1
best types and sizes | <input type="checkbox"/> 250—ASST. WOOD SCREWS \$1
finest popular selection |
| <input type="checkbox"/> 250 — ASST. SELF TAPPING SCREWS #6, #8, etc. \$1 | <input type="checkbox"/> 150—ASST. 6/32 SCREWS and 150 6/32 HEX NUTS \$1 | <input type="checkbox"/> 150—ASST. 8/32 SCREWS and 150—8/32 HEX NUTS \$1 | <input type="checkbox"/> 150—ASST. 2/56 SCREWS and 150—2/56 HEX NUTS \$1 |
| <input type="checkbox"/> 150—ASST. 4/40 SCREWS and 150—4/40 HEX NUTS \$1 | <input type="checkbox"/> 150—ASST. 5/40 SCREWS and 150—5/40 HEX NUTS \$1 | <input type="checkbox"/> 500—ASSORTED RIVETS most useful selected sizes \$1 | <input type="checkbox"/> 500—ASSORTED WASHERS most useful selected sizes \$1 |
| <input type="checkbox"/> 100 — ASST. RUBBER & FELT FEET FOR CABINETS best sizes \$1 | <input type="checkbox"/> COMBINATION TAPE RECORDER & RADIO—\$60 Deluxe Portable needs adjusting, money-back basis \$9 | <input type="checkbox"/> HEARING AID AMPLIFIER incl. 3 Tubes, Mike, etc. (as is) \$2 | <input type="checkbox"/> UNIV. 3" x 5" PM SPEAKER Rest type for Radios, TV, Etc. 75¢ |
| <input type="checkbox"/> 10 — SPEAKER PLUG SETS deluxe type, 2 conductor \$1 | <input type="checkbox"/> 300 — ASST. 1/2 W RESISTORS Top Brand, Short leads, excellent \$1 | <input type="checkbox"/> 5 — I.F. COIL TRANSFORMERS sub-min for Transistor Radios \$1 | <input type="checkbox"/> 5 — AUDIO OUTPUT TRANSFORM Sub-min for Trans Radios \$1 |
| <input type="checkbox"/> 4 — TOGGLE SWITCHES SPST, SPDT, DPST, DPDT \$1 | <input type="checkbox"/> 70—BRASS FAHNESTOCK CLIPS popular type & size, plated \$1 | <input type="checkbox"/> 32—TEST PROD WIRE deluxe quality, red or black \$1 | <input type="checkbox"/> SOLDERING IRON pencil-type deluxe, AC/DC, 110-120v, 30w \$1.65 |
| <input type="checkbox"/> 100—ASST 1/4 WATT RESISTORS stand. choice ohmages, some in 5% \$1 | <input type="checkbox"/> 100 — ASST 1/2 WATT RESISTORS stand. choice ohmages, some in 5% \$1 | <input type="checkbox"/> 70 — ASST 1 WATT RESISTORS stand. choice ohmages, some in 5% \$1 | <input type="checkbox"/> 35 — ASST 2 WATT RESISTORS stand. choice ohmages, some in 5% \$1 |
| <input type="checkbox"/> 50 — PRECISION RESISTORS asst. list-price \$50 less 98% \$1 | <input type="checkbox"/> 20 — ASS'TED WIREWOUND RESISTORS, 5, 10, 20 watt \$1 | <input type="checkbox"/> 100 — ASST. MICA CONDENSERS some in 5% \$1 | <input type="checkbox"/> 50 — ASST. TERMINAL STRIPS all types, 1-lug to 6-lug \$1 |
| <input type="checkbox"/> 25 — INSTRUMENT POINTER KNOBS selected popular types \$1 | <input type="checkbox"/> \$15.00 RADIO PARTS "JACK-POT" handy assortment \$1 | <input type="checkbox"/> 5 — PNP TRANSISTORS general purpose, TO-5 case \$1 | <input type="checkbox"/> 5 — NPN TRANSISTORS general purpose, TO-5 case \$1 |
| <input type="checkbox"/> 10 — ASST DUAL CONTROLS for Radio, TV, Hi-Fi, Stereo, etc. \$1 | <input type="checkbox"/> DELUXE ELECTRIC GUITAR quality, performance, price ready for any amplifier \$22 | <input type="checkbox"/> TAPE RECORDER — assorted types good, bad, broken, as-is, potluck \$4 | <input type="checkbox"/> TRANSISTOR RADIO <i>asst type</i> good, bad, broken, as-is, potluck \$1.50 |
| <input type="checkbox"/> S4 ELECTRIC FOOT SWITCH deluxe type for any equipment \$1 | <input type="checkbox"/> 6 — TRANSISTOR RADIO EAR-PIECES wired complete with plug \$1 | <input type="checkbox"/> 50 — ASSORTED MYLAR CONDENSERS popular selected types \$1 | <input type="checkbox"/> TELEPHONE RECORDING DEVICE instant suction cup fit \$1 |
| <input type="checkbox"/> CRYSTAL LAPPEL MICROPHONE high impedance, 200-6000 cps \$1 | <input type="checkbox"/> 25' — MICROPHONE CABLE deluxe, 2 conductor, shielded \$1 | <input type="checkbox"/> 50—TUBE CARTONS (colored) assorted sizes for Popular Tubes \$1 | <input type="checkbox"/> 10 — ASSORTED TUBES Radio, Television and Industrial \$1 |
| <input type="checkbox"/> ALL AMERICAN TUBE KIT Top Standard Brand — 12BA6, 12BE6, 12AV6, 50C5, 35W4 \$2 | <input type="checkbox"/> 15 — ASST. ROTARY SWITCHES all popular types \$20 value \$1 | | |

MERCHANDISE WANTED in any quantity — TUBES (all types) — RADIO & TV PARTS — EQUIPMENT finished or unfinished — immediate cash.
Please send samples, quotes & amounts — only new merchandise bought.

#98 Retail Price \$5.00

#99 Retail Price \$5.95

#105 Retail Price \$5.75

#128 Retail Price \$8.95

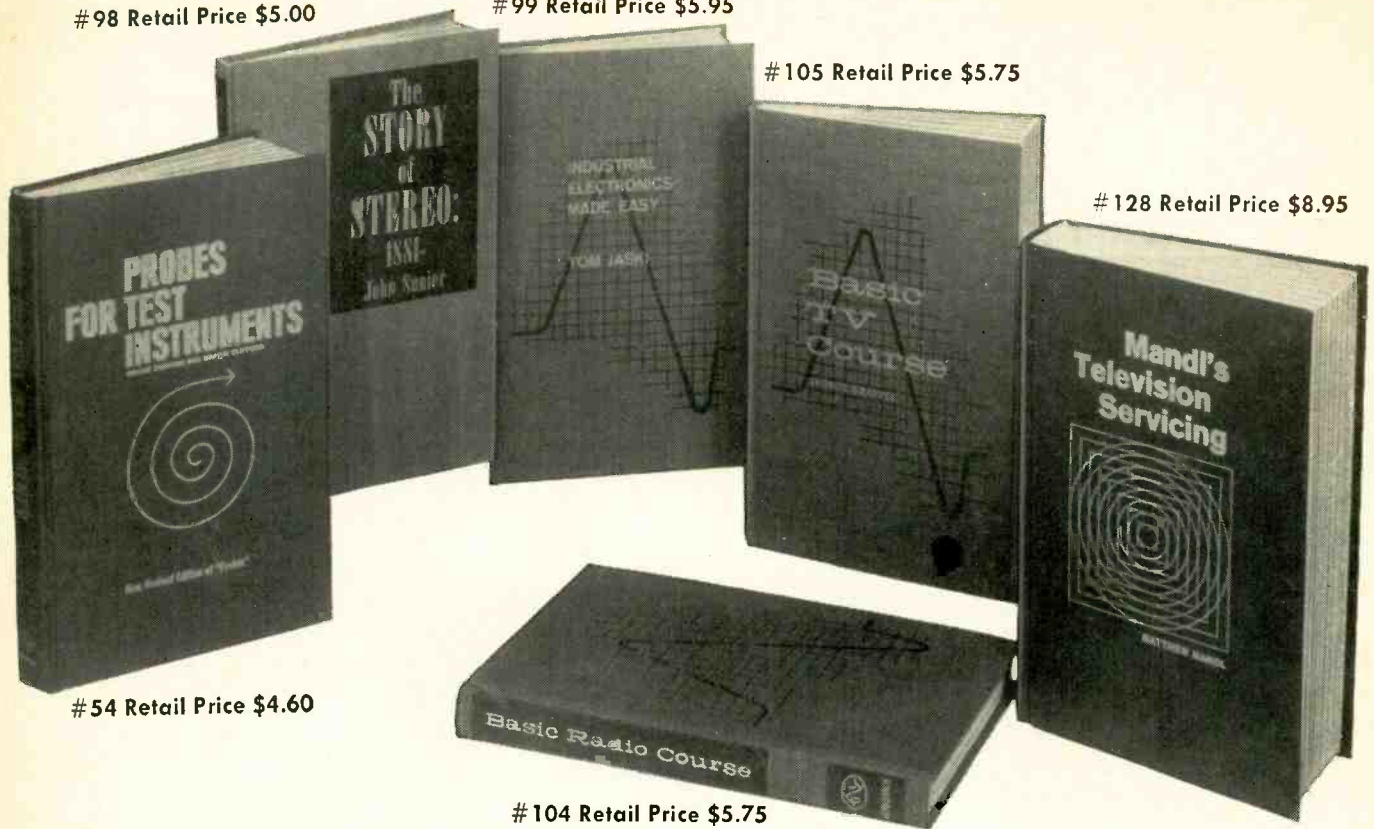

#54 Retail Price \$4.60

#104 Retail Price \$5.75

Accept any 3 of these important electronic works for \$2.00!

Retail value up to \$20.65 . . . yours with trial membership in the famous
Gernsback Electronics Book Club.

An extraordinary offer to introduce you to Gernsback Library's famous Electronics Book Club, especially designed to help you increase your know-how, earning power and enjoyment of electronics.

Whatever your interest in electronics—radio and TV servicing, audio and hi-fi, industrial electronics, communications, electronics as a hobby—you will find that the Electronics Book Club will help you get the job you want, keep it, improve it or make your leisure hours more enjoyable. With the club providing you with top quality books, you may broaden your knowledge and skills to build your income and increase enjoyment of electronics, too

What books are offered? From Gernsback Library and other leading technical publishers come the country's most respected books in the field of electronics. Each one is written by a professional, acknowledged expert in his field and designed with you in mind. All are deluxe, hardbound books to be used as a basic tool and offered at considerable cash savings to members—up to 50% off list price—regardless of higher retail prices.

How the club works. The Electronics Book Club will send you every other month the news bulletin describing a new book in a vital area of electronics. As a member, you alone decide whether you want a particular book or not. You get 3 books worth up to \$20.65 now for \$2.00 and need take only 4 more within the year, from a wide selection to be offered. Every year the club offers about 25 high quality, hardbound books on electronics. The club saves you money on the books you take, regardless of higher retail prices.

How to join. Mail the coupon below today. You will be sent your 3 books immediately. We will bill you \$2.00 (plus a few cents postage). If you are not pleased, send the books back within 10 days and membership will be cancelled. Otherwise you will enjoy all these benefits:

1. Free 10 day examination privilege.
2. Continuous cash savings.
3. Free charts given with many books.
4. You alone decide which books you want.
5. Club books are practical working tools written by experts.

**Gernsback Library, Inc., Electronics Book Club, Dep't. RE 67
154 West 14 Street, New York, N.Y. 10011**

Please enroll me in the Electronics Book Club and send me the 3 books I have circled below. Bill me only \$2.00 plus shipping. If not pleased I may return the books within 10 days and this membership will be cancelled.

As a member, I need accept as few as 4 additional books a year and may resign any time after purchasing them. All books will be described to me in advance in the club bulletin and a convenient form will always be provided for my use if I don't wish to receive a forthcoming book.

Offer good in U.S.A. and Canada only.

Circle 3 book numbers: 54 98 99 104 105 128

Name

Address

City State Zip

RADIO-ELECTRONICS

COMPUTER BRIEFS

A time-shared computer has been used by students at the Thayer School of Engineering (Dartmouth College, Hanover, N.H.) for the past 3 years. Around the Dartmouth campus are located 30 teletype machines connected to a common computer. The system is active 20 hours per day, 7 days a week. The computer can process problems from all 30 inputs simultaneously, thus broadening its application and cutting unit costs.

Meanwhile, at Towson, Md., a plan is taking form to link 7 Maryland colleges in a computer network. The computer will be located on the campus of Towson State College and shared by all 7 schools. As above, the sharing process will cut individual cost for each user.

At Carnegie Institute of Technology (Pittsburgh) a computer is being used to explore what makes people tick. Behavioral scientists are studying the way men and women learn and solve problems. The computer records and analyzes the data.

COLOR TV NEWS

The first 8-year warranty on color CRT's has been offered by Curtis Mathes Mfg., of Dallas. The guarantee costs the consumer \$12, or \$1.50 per year. If the picture tube fails during the first year, it's replaced free. During the remaining years, the customer pays part of the cost—\$25 the second year, \$50 the third, and so on, up to \$175 during the eighth year.

Two new color TV sets have pushed prices and sizes down still further. G-E has reduced to under \$200 its 24-1b portable with a 60 square-inch picture (11-inch viewable diagonal). RCA has put its first small portable on sale. The receiver has a 102-square-inch picture (14-inch viewable diagonal), weighs 40 lbs, and carries a list price of \$329.95.

Great Britain—due to get regularly scheduled color TV this fall—is finding rising arguments over the proposed arrangement. The BBC has been authorized to transmit color on both its channels, while the ITV commercial service can use only a single channel for color.

There is also criticism of a government plan to convert all services to uhf using 625-line standards. Service will be maintained on vhf with 405 lines until existing receivers have been reasonably worn out. END

CRYSTALS are not all the same!



If your dealer is temporarily out of stock or does not carry Texas Crystals, send us his name along with your request for catalog to our plant nearest you.

Texas Crystals quality is outstanding as evidenced by use in numerous government space projects where there's no compromise with quality, reliability or accuracy. The same dependable performance is yours for CB operation on all 23 channels at only \$2.95 per crystal.



Send for Free Catalog with Circuits

TEXAS CRYSTALS

A Division of Whitehall Electronics Corp.

1000 Crystal Drive 4117 W. Jefferson Blvd.
Fort Myers, Florida Los Angeles, California
Phone 813 WE 6-2109 Phone 213 731-2258

Circle 140 on reader's service card

U.S. GOV'T ELECTRONIC SURPLUS

Nationally Known-World Famous SURPLUS CENTER offers finest, most expensive, Government Surplus electronic units and components at a fraction of their original acquisition cost.

ORDER DIRECT FROM AD or WRITE FOR CATALOGS

STANDARD DIAL TELEPHONE

(ITEM #715) - Standard, commercial telephone same as used throughout U.S.A. Attractive polished black, like new condition. Use as extension phone to private systems or connect several phones together for local intercom system. Full instructions are furnished. Wt. 9 lbs. Original Cost \$24.50.



F.O.B. \$5.95

STEP-BY-STEP AUTOMATIC SWITCH

(ITEM #738) - Amazing "up-and-around" electro-magnetic telephone switch. With any bank pair from 1 to 100. Make your own telephone system. Can also be used to remotely control up to 100 circuits over a single pair of wires.

One of our FOUR STAR bargains. Comes complete with data, one dial and one line bank. Size, 5" x 7" x 1 1/2". Wt. 16 lbs. Cost Gov't Over \$75.00. Complete; Switch, cover, dial, line bank, instructions.....

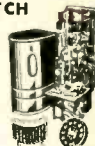

F.O.B. \$9.95

TYPICAL BUYS FROM OUR 1967 CATALOGS

- \$ 350.00 - Geared 2-hp Battery Golf Car Motor \$24.95
- \$ 15.00 - Westinghouse DC Ammeter, 0 to 300 \$ 7.11
- \$ 40.00 - Vacuum/Pressure Pump, 12-VDC \$11.95
- - - 80-MW Walkie-Talkies, Per Pair \$19.60
- - - Deluxe, Multi-Range, AC/DC Tester \$ 8.98
- \$4000.00 - Carrier Telephone Amplifier System \$13.91

SPECIAL SALE Correspondence Course In ELECTRICAL ENGINEERING



Sells For \$10.79 Outside U.S.A. \$8.79 Postpaid in U.S.A.

(ITEM #A181) - Wonderful chance to obtain technical training at Amazing Low Cost! Lincoln Engineering School has suspended its Correspondence Courses because of increased operating costs. We offer a limited number of the school's complete Electrical Engineering Course but without the examination paper grading service. The course consists of 14 lesson and books. Each book has the regular exams, and in a separate section, "Standard Answers" to each exam question.

Course is well written, easy to understand, profusely illustrated. Reader's digest size, easy to carry and study in spare time. Many Lincoln Engineering School students holding excellent jobs as a result of L.E.S. training. Course contains latest information on transistors, silicon diodes, etc. Additional book on how to build and operate a "Home Laboratory and Experimental Bench" furnished with each course.

SEND 25¢ COIN OR STAMPS FOR 3 MAIN CATALOGS

All Items FOB Lincoln Money Back Guarantee



SURPLUS CENTER

DEPT. RE-067 LINCOLN, NEBR. 68501

Circle 141 on reader's service card

LAB-TYPE TONE-BURST GENERATOR

Introducing a versatile test instrument new to many readers. IC modules simplify construction. **Details in July RADIO-ELECTRONICS**

ELECTRONICS



Engineering-Technicians

Bachelor of Science Degree, 30 Months
Save Two Years' Time

- Radio-Television Plus Color Technician (12 Months)
- Electronics Engineering Technology (15 Months)
- Electronics Engineering (B.S. Degree)
 - Electrical Engineering (B.S. Degree)
 - Mechanical Engineering (B.S. Degree)
 - Civil Engineering (B.S. Degree)
 - Architecture (B.S. Degree) (36 Months)

Approved for Veterans

DAY AND EVENING CLASSES

Write for Catalog and Registration Application.
New Term Starting Soon.

Your Name

Address

City

State



1215 Van Ness Avenue
San Francisco, California

Circle 134 on reader's service card

NEW POWER POWER

FROM

FINCO

Model 65-3 VHF-TV ANTENNA AMPLIFIER

improves reception of WEAK VHF-TV signals in FRINGE AREAS even where strong local TV or FM signals are present. AMPLIFIES UP TO 7 TIMES for Better Color and B/W

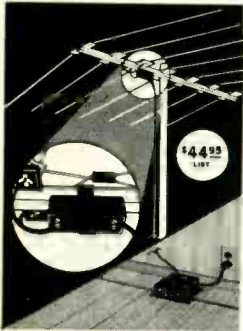

Model 65-3 VHF-TV ANTENNA AMPLIFIER

A two-transistor-amplifier. Engineered to provide the lowest noise and highest amplification with the most desirable overload characteristics.

Amplifier used in conjunction with dual outlet power supply for one, two, or multiple set installations. 117 V 60 cycle input. AC power up to amplifier: 24 volts-60 cycle.

Let Finco solve your Color and B & W reception problems. Write for complete information, schematics and specifications. Form #20-357.

THE FINNEY COMPANY

34 West Interstate St. • Bedford, Ohio 44014 • Dept. RE
Circle 132 on reader's service card

"ARCTURUS" COLOR TV SPECIALS

- Original Color Flybacks for RCA, GE, Emerson, Magnavox, Muntz, Olympia, Philco, Silvertone, Sylvania, etc. List price \$24.00. Our price \$9.95. Cat. #CTVF1.
- Original Color Yokes for all makes of color TV. 70 degree for all round color CRT's. Cat. #XRC70; 90 degree for all rectangular 19 to 25 inch CRT's. Cat. #XRC-90. List price \$50.00. Our price \$12.95 each.
- Color Focus Rectifiers, 6.5 K.V., Cat. #CFR5-\$1.95.
- Color Silicon Rectifiers, 1-5 amps, 2000 p.i.v. Cat. #CFR10, \$1.19.
- Color Picture Tubes. Write for special low prices.
- Color TV Receiving Tube types. Listed in our Catalog at very special prices.
- Color TV CRT Sockets. Cat. #CSO 19. 79¢ each.
- New Tube Specials: IAX2—replacement or substitute for 1X2, 1X2A. IS2, 49¢ each. 5 for \$2.00. 2C40 Light-house Tube, usually \$14.00, special 99¢ each.
- Black and white TV Yokes—order by Thordarson or Merit #. Any "Y" number from Y40 to Y106, any "MFO" number from 106 to 143. In stock, complete with hook-up instructions—cost \$4.95 each. Black and white TV 110 degree Yokes, original equipment for most models of Admiral, Emerson, Dumont, Magnavox, Motorola, Philco, Silvertone, Westinghouse, Zenith, RCA. Order by set makers number. Cost \$7.50 each.
- Stromberg-Carlson Transistorized Intercoms, AC only. Seven Station Master \$12.95, Cat. #SCT11. Remote Stations for SCT11, \$4.95 each, Cat. #SCTR2. With hook-up instructions.
- Transistorized UHF Tuners used in 1965, '66, '67 TV sets by Admiral, Dumont, Magnavox, Motorola, RCA, Philco, Olympia, Sylvania, Silvertone. Only difference from one to another: removable gearing may differ. Easy replacement. No filament voltage required. Needs only 15 volts D.C. to function. Cat. #UHFT-1, \$4.95.
- Kit of 30 tested Germanium Diodes. Cat. #100, 99¢.
- Kit of 15 Sub-miniature Tubes, 99¢. Cat. #29
- Silicon Rectifier long-life replacement for 5U4, 5Y3, 5AS4, 5AU4, 5AW4, 5T4, 5V4, 5Z4. Octal based. With diagram: Cat. #RECT-1, 99¢ each. 024 long-life Silicon Rectifier replacement, octal based, Cat. #RECT-2, 99¢ each.

Send for FREE CATALOG listing thousands of similar items at lower-than-fair prices. We thank you now—you'll thank us later.

ARCTURUS ELECTRONICS CORP.

502-22nd St., Union City, N.J. 07087 Dept. RE-6
Phone 864-5568 (Area Code 201)

Circle 133 on reader's service card

NOTEWORTHY CIRCUITS

TV/FM ANTENNA COUPLER

Want to couple your FM tuner and TV to the same antenna? It's really quite easy to do. Two methods are shown. Fig. 1 uses three 910-ohm 5% resistors in a delta arrangement. Fig. 2 requires four 150-ohm resistors in series with the inputs.

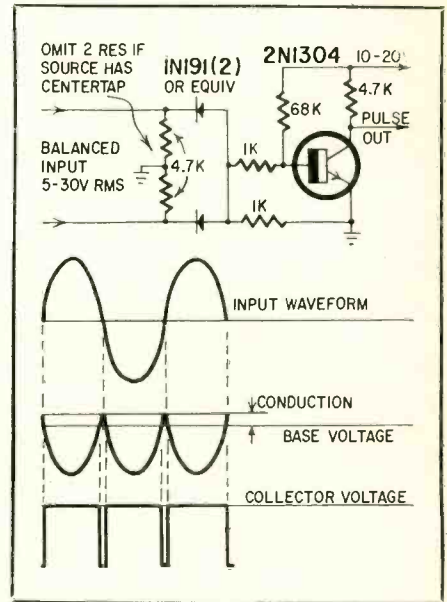
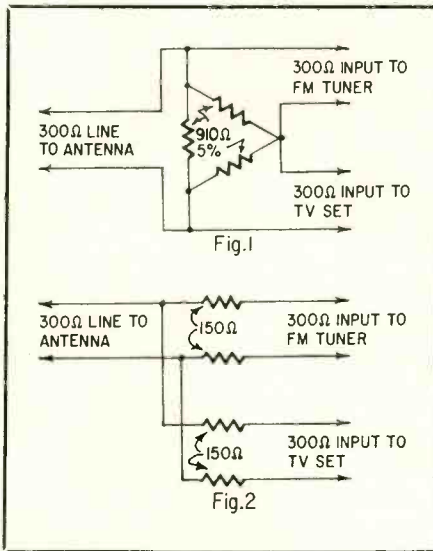

voltage approaches zero, the transistor is turned on by current from the power supply through the base bias resistor. Since both half-cycles of the input signal turn the transistor off, one narrow pulse is developed each time the input signal crosses the zero line.

This circuit generates negative pulses approximately equal to the supply voltage. Positive pulses can be obtained by reversing the diodes and supply voltage and substituting a pnp transistor such as the 2N1305.

I use this circuit to trigger the base-step generator in a transistor characteristic-curve tracer. It has always functioned reliably and well.

—Matthew L. Fichtenbaum

END

Both circuits, which you can put together in matter of minutes, work well, though I prefer the delta arrangement. The two receivers are isolated from each other, yet proper impedance matching to the antenna line is preserved.—Larry Steckler

SIMPLE ZERO-CROSSING DETECTOR

In our lab, we often need a circuit that will produce a sharp pulse each time an input sine wave crosses the zero line. This inexpensive foolproof circuit develops a square pulse centered on the zero crossing of the input signal. Drift in component values or operating voltage cannot affect pulse timing, only pulse width. The only requirement is that the source be balanced with respect to ground. (Sources that cannot be grounded directly can be used if a 2-μF capacitor is inserted in series with each input lead.) Input level is in the range of 5 to 30 volts rms.

Here is how the circuit works: The diodes rectify the input signal and develop a negative voltage that keeps the transistor turned off. Just as the input

BIG TEST INSTRUMENT ISSUE

Features seven build-it-yourself precision test instruments plus articles explaining how to use, check, recalibrate and get the best out of your instruments. Don't miss

July RADIO-ELECTRONICS

**Solution to
R-E Puzzler for
May 1967**

- | | |
|-------------------|--------------------|
| 1 undermodulation | 13 beta |
| 2 chromatron | 14 helical |
| 3 amplistat | 15 cadmium |
| 4 heptode | 16 manganin |
| 5 attenuator | 17 glissando |
| 6 standardize | 18 residual |
| 7 magnesium | 19 sensitivity |
| 8 console | 20 wattmeter |
| 9 oscilloscope | 21 bifilar |
| 10 binistor | 22 theremin |
| 11 nanoampere | 23 waveform |
| 12 permeance | 24 orange |
| | 25 misregistration |

Subtract 4 points for each part you didn't answer correctly.

Your rating:

- | | | | |
|-------|----------|---------------------------|--------------|
| 60-64 | Fair. | 76-84 | Better. |
| 68-72 | Good. | 88-96 | Even better! |
| 100 | Perfect! | Pat yourself on the back. | |

By Edmund A. Braun

NEW BOOKS

HANDBOOK OF STROBOSCOPY, by Frederick van Veen. General Radio Co., West Concord, Mass., 6 x 9 in., 120 pp. Paper, \$1.00

An excellent small book on the subject, although devoted mainly to General Radio's strobe equipment. Discusses stroboscopy, the stroboscope as a tachometer, slow-motion and stopped-motion observation with the stroboscope, and high-speed photography. Well indexed, easy to read, well illustrated.

MATHEMATICS FOR ELECTRICAL CIRCUIT ANALYSIS, by D. E. Howson. Pergamon Press, Inc., 44-01 21 St., L. I. City, N. Y. 11101. 5 x 7 3/4 in., 170 pp. Paper, \$3.50

Strictly a mathematics book for advanced circuit analysis. Covers determinants, differential equations, matrix analysis, linear networks, Fourier analysis, and Laplace transforms. Good for self-help, with lots of examples for the reader to work at the end of each chapter. Solutions to the examples are in the back. **END**

50 Years Ago

In Gernsback Publications
From June, 1917
Electrical Experimenter

Talking Motion Pictures Via Wireless
Electricity and Water to Run Our Autos
The Naval Radio Operator
Amateur Hears Spy Radio Code

TRY THIS ONE

DESOLDERING TOOL

This desoldering tool is easily made from a 35- to 50-watt soldering iron with a tip 1/4 to 1/2 inch in diameter.

Cut the tip off square and silver-solder or braze on three "tiptlets" 2 inches long of No. 10 copper wire. Allow 1/2 inch of the tiptlets to overlap the tip. Space the tiptlets equally around the circumference. (Welding or plumbing shops will do such brazing for a modest charge.)

For use, bend the tiptlets to suit triangular or in-line transistor lead configurations. Or bend one out of the way when only two are needed, as for resistors, etc. Try to bend each tiptlet the same amount so that the overall length remains fairly equal.

Such a tool made from a 35-watt Kwikheat iron easily melts 60/40 solder on a printed-circuit board.

—R. C. Roetger

END

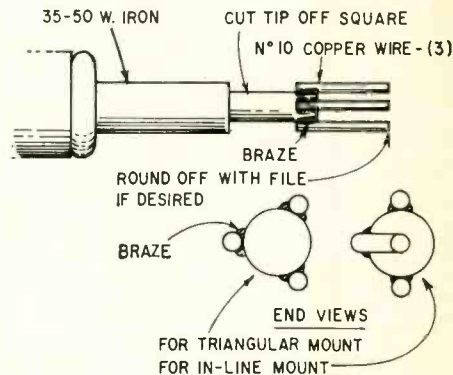

Radio-Electronics Is Your Magazine!

Tell us what you want to see in it. Your suggestions may make it a better magazine for the rest of the readers as well as yourself. Write to the Editor, RADIO ELECTRONICS, 154 West 14th St., New York, N. Y. 10011.

SCHOOL DIRECTORY

Get Your First Class Commercial

F. C. C. LICENSE

thru spare-time study by correspondence. Our money-back warranty protects your investment. (Approved for Veterans) Write for Brochure 67. It's free.

Grantham School of Electronics
1505 N. Western Av., Hollywood, Cal. 90027

for a professional career

Tri-State graduates hold important engineering and business administration posts throughout the U. S. This professionally-oriented small college has outstanding placement record. Four-quarter year permits degree in three years. Excellent faculty. Well-equipped labs.

Beautiful 300-acre campus. Accredited. Small classes. Modest costs. One-year Drafting-Design Certificate program. Enter Sept., Jan., March, June. For Catalog, write Director Admissions indicating career interest.

TRI-STATE COLLEGE
2467 College Avenue. Angola, Indiana 46703

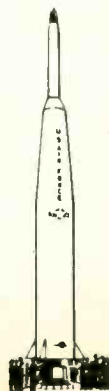

Learn Electronics for your SPACE-AGE EDUCATION at the center of America's aerospace industry

No matter what your aerospace goal, you can get your training at Northrop Tech. in sunny Southern California.

COLLEGE OF ENGINEERING. Get your B.S. degree in engineering in just 36 months by attending classes year round. Most Northrop Tech graduates have a job waiting for them the day they're graduated!

A & P SCHOOL. Practical experience on real aircraft. One-year course prepares you for F.A.A. A & P certificate. **WRITE TODAY FOR CATALOG.**

NORTHROP INSTITUTE OF TECHNOLOGY
1199 W. Arbor Vitae, Inglewood, Calif.

Let COYNE Train You AT HOME for Big Pay in



TELEVISION RADIO COLOR TV

MAIL COUPON FOR FREE BOOK

Coyne Electronics Institute Dept. A7-C5
1501 W. Congress Pkwy., Chicago, Ill. 60607
Send **FREE** Book showing how I can get Coyne Quality Home Training in TV-Radio at Low Cost on Easy Terms.

Name.....
Address.....
City..... State..... Zip.....
Phone..... Age.....

Put X here if interested in Resident School for Associate Degree in Electronics Engineering and Technology, or shorter courses in Electricity, Radio-TV, Electronics. Approved GI Bill. Spare time employment and tuition payment plans available.

GET INTO ELECTRONICS

V.T.I. training leads to success as technicians, field engineers, specialists in communications, guided missiles, computers, radar and automation. Basic & advanced courses in theory & laboratory. Electronic Engineering, Technology and Electronic Technology curricula both available. Assoc. degree in 29 mos. B.S. also obtainable. G.I. approved. Graduates in all branches of electronics with major companies. Start Sept., Feb. Dorms, campus. High school graduate or equivalent. Catalog.

**VALPARAISO TECHNICAL
INSTITUTE**
Department C, Valparaiso, Indiana



ADVERTISING INDEX

RADIO-ELECTRONICS does not assume responsibility for any errors which may appear in the index below.

Allied Radio Corp.	64
Arcturus Electronics Corp.	90
B & K Manufacturing Co., Inc.	13
Brooks Radio & TV Corp.	86-87
Browning Laboratories, Inc.	82
Capitol Radio Engineering Institute, The	15
Castle TV Tuner Service, Inc.	64
CLASSIFIED	92-95
Cleveland Institute of Electronics	7, 28-31
Cornell Electronics Co.	94

Data Corporation, The	78
Delta Products, Inc.	75
DeVry Institute of Technology	5

Electro-Voice, Inc.	25
Electronic Measurement Corp. (EMC)	26

Fair Radio Sales	79
Finney Co.	74, 90

Gernsback Library Inc.	80-81, 88
------------------------	-----------

Heald Engineering College	89
Heath Company	27, 68-69

International Crystal Mfg. Co., Inc.	96
--------------------------------------	----

Jerrold Electronics Corporation (Distributor Sales Division)	23
JFD Electronics Corp.	17
Judson Research and Mfg. Co.	76

Lafayette Radio Electronics	78
-----------------------------	----

Mallory Distributor Products Company (Div. of P. R. Mallory & Co., Inc.)	Third Cover
Microflame, Inc.	83
Multicore Sales Corp.	86
Music Associated	87

National Radio Institute	8-11
--------------------------	------

Olson Electronics, Inc.	74
Oxford Transducer Company (A Division of Oxford Electric Corporation)	16

Permotlux Corp.	79
Poly Paks	95

Radio Shack	1
RCA Electronic Components and Devices Tubes	Fourth Cover
RCA Institutes, Inc.	18-21
RCA Parts and Accessories	67
Round Hill Associates Inc. (A Milo Electronics Subsidiary)	73
Rye Industries, Inc.	82, 83

Salch & Co., Herbert (Marketing Division of Tompkins Radio Products)	76
Sams & Co., Inc., Howard W.	6
Scientific Associates Corporation	14
Score	65, 85
Solid State Sales	92
Sonotone Corp. (Electronic Applications Div.)	22
Sony Corp. of America	26
Sprague Products Company	24
Surplus Center	89

TechPress, Inc.	84
Texas Crystals (Div. of Whitehall Electronics Corp.)	89
Triplet Electrical Instrument Company	Second Cover

United Radio Co.	93
------------------	----

Warren Electronic Components	94
------------------------------	----

Xcelite, Inc.	12
---------------	----

MARKET CENTER	92-95
Chemtronics	
Edmund Scientific Corp.	
TAB	

SCHOOL DIRECTORY	91
-------------------------	-----------

Coyne Electronics Institute
 Grantham School of Electronics
 Northrop College of Science & Engineering
 Tri-State College
 Valparaiso Technical Institute

MARKET CENTER

GENERAL

CONVERT ANY TELEVISION to sensitive Big-Screen Oscilloscope. Only minor changes required. No electronic experience necessary. Illustrated plans \$2.00. RELCO-A25, Box 10563, Houston 18, Texas

TV SERVICE ORDER BOOKS for use with your rubber stamp. Duplicate or triplicate. Low cost. Write for FREE 32 PAGE CATALOG and Special Rubber Stamp Offer. OELRICH PUBLICATIONS, 6556 W. Higgins, Chicago, Ill. 60656

FREE ELECTRONICS (new and surplus) Parts catalog. We repair multimeters. BIGELOW ELECTRONICS, Bluffton, Ohio 45817

PRINTING PRESSES, Type, Supplies. Lists 5¢. TURNBAUGH SERVICE, Mechanicsburg, Pa.



BLACK/WHITE OR COLOR
TV TUNER CLEANERS
 THE ONLY SAFE NON-DRIFT TV TUNER CLEANERS AVAILABLE AT ALL DISTRIBUTORS
CHEMTRONICS
 BROOKLYN, N. Y. 11236



ALL OUR TRANSISTORS & RECTIFIERS ARE GUARANTEED TO WORK.

All transistors are checked for minimum voltage & gain to insure our customers a good transistor within the category we advertise. All rectifiers costing over \$.10 checked for forward voltage & leakage as well as PRV. The gates on our SCR's are also checked. All nonoperable units will be refunded or exchanged immediately. We will stand on our reputation for quality devices and service.

DO NOT CONFUSE OUR PRODUCTS WITH THOSE OF SOME OF OUR COMPETITORS. A defective semi-conductor is worthless or worse.

Users of the above mentioned items in large quantities send us your specifications. We feel we can meet them at a competitive price.

INTEGRATED CIRCUITS



JK FLIP FLOPS	\$1.15
DUAL NAND NOR GATES	\$1.00
SR CLOCKED FLIP FLOPS	\$1.15
SRT FLIP FLOPS	\$1.15
EXPANDABLE OR GATES	\$1.00

Guaranteed to work TO-85 flat pack

They come complete with schematic, elect. characteristic sheet, + some typical applications. \$9.00-\$15.00. From original manu.

"N" Channel FET'S SIM. to 2N3088 Used As Amp, Switch, Chopper—Very High Input Z Each \$1.50

Silicon Power Rectifiers

PRV	3A	20A	40A	240A
100	.10	.40	1.00	5.00
200	.20	.60	1.50	7.00
400	.25	.80	2.00	12.00
600	.35	1.20	2.50	20.00
800	.45	1.50	3.00	
1000	.65		3.50	35.00

1.25 Amp (Glass Amps)

A controlled avalanche rectifier in which the PRV may be exceeded without destroying the rectifier.

PRV	
100	.12
200	.15
400	.20
600	.25
800	.35
1000	.50

Top Hat & Epoxy

PRV	AMP
100	.07
200	.09
400	.12
600	.20
800	.25
1000	.50
1200	.65
1400	.85
1600	1.00
1800	1.20

Silicon Control Rectifiers TO-66 pack Studs

PRV	3A	7A	20A
50	.35	.50	.80
100	.50	.70	1.35
200	.75	1.05	1.90
300	1.25	1.60	2.45
400	1.50	2.10	2.85
500	1.75	2.80	3.50
600	2.00	3.00	
700	2.25	3.50	
1000		5.00	

Terms: FOB Cambridge, Mass. Send check or Money Order. Include Postage, Average Wt. per package 1/2 lb. Allow for C.O.D. Minimum Order \$3.00

SIM. to 2N728(NPN). A high frequency TO-18 unit extending to the UHF range 3/\$1.00

SIM. to 2N995 (PNP). Silicon in TO-18 case. 500 MW power, to 180 MHz frequency 3/\$1.00

GLASS DIODES color coded. Silicon 20/\$1.00 30/\$1.00 6E

SIM. to 2N2875 (PNP). Silicon 20 watts with 30 MHz cut off \$1.75

SIM. to 2N1648 (NPN) high voltage 40 Watt silicon unit, used in power output stages & power transistor drivers \$1.75

10 WATT ZENERS. 2—180V. State desired voltages Ea. \$1.75

SILICON BILATERAL SWITCH. Replaces two SCR's by firing in either direction when breakdown voltage is exceeded. Used in light dimmers, etc. Ea. \$1.75

GaAs VARACTORS, sim. to AP-1, AP-6, etc. 70 GHz at 150 MW with characteristic sheet. Ea. \$4.00

NPN DUAL TRANSISTORS. A TO-5 package (2N2060) containing 2 high-gain 100 MHz silicon transistors \$1.50

PNP DUAL TRANSISTORS. A TO-5 package (2N2807) containing 2 high-gain 100 MHz PNP transistors \$1.50

HIGH-VOLTAGE NPN 150V VBC80 at 2.5A, hi gain in TO-66 pack \$1.75

HIGH-VOLTAGE ASSEMBLIES, 6000V at 150 ma.

These silicon units may be put in series to achieve higher volts. \$1.50

DUAL 20 µF at 350 V Electrolytics 3/\$1.00

28-101 P CERAMIC TRIMMERS 6/\$1.00

POST OFFICE BOX 74 D

SOMERVILLE, MASS. 02143

Send For Our Latest Catalog

Name _____

Address _____

City _____ State _____

Circle 142 on reader's service card

New scientific transistor instrument detects buried coins, treasures. Will detect gold, silver, copper, iron, etc. \$19.95 up. Free catalog. **RELCO-A-25**, Box 10563, Houston 18, Texas

GIANT TESLA COIL—FORTY INCH SPARKS! Complete plans \$5.00. Details, color photo 50¢ (deductible). **HUNTINGTON ELECTRONICS, INC.**, Dept. R, Box 9, Huntington Station, Shelton, Conn. 06484

WANTED

QUICK CASH . . . for Electronic EQUIPMENT, COMPONENTS, unused TUBES. Send list now! **BARRY**, 512 Broadway, New York, N. Y. 10012, 212 WALKER 5-7000

WANTED: Radar Equipment AN/TPS-10D, APT-9, SCR-584, AN/GPG-1, M-33 etc., P. J. PLISHNER, 550 Fifth Avenue, N. Y. Tele: 212 JU 6-4691

WANTED: USED Capitol Radio Engineering Institute course in Communications Engineering. **K.R.L.**, 1408 South 52 Street, Milwaukee, Wisc. 53214

AUDIO — HI-FI

RENT STEREO TAPES—over 2,500 different—all major labels—free brochure. **STEREO PARTI**, 1616-R Terrace Way, Santa Rosa, Calif. 95404

HI-FI COMPONENTS, Tape Recorders, at guaranteed "WE will not be undersold" prices. 15-day moneyback guarantee. Two-year warranty. NO Catalog. Quotations Free. **HI-FIDELITY CENTER**, 239R East 149th St., N.Y., N.Y. 10451

TAPE RECORDER SALE. Brand new, latest models, \$10.00 above cost. **ARKAY SALES**, 1028-E Commonwealth Ave., Boston, Mass. 02215

WRITE for highest discounts on components, recorders, tapes, from franchised distributors. Send for **FREE** monthly specials. **CARSTON**, 1686-R Second Ave. N.Y.C. 10028

STEREO TAPES. Save up to 60% (no membership fees, postpaid anywhere USA). Free 60-page catalog. We discount batteries, recorders, tape accessories. Beware of slogans "not undersold," as the discount information you supply our competitor is usually reported to the factory. **SAXITONE**, 1776 Columbia Road, Washington, D. C. 20009

TAPEMATES makes available to you ALL 4-TRACK STEREO TAPES—ALL LABELS—postpaid to your door—at tremendous savings. For free brochure write **TAPEMATES CLUB**, 5727 W. Jefferson Blvd., Los Angeles, Calif. 90016

RECORD COLLECTION FOR SALE. Classics, jazz, country, folk, foreign. Send for lists. **HAWKES**, 58 Hardy Rd., Westbrook, Maine 04092

HI-FIDELITY COMPONENTS. Ham Marine and Communication equipment at considerable savings. If you want to save money write us for our low prices on all your needs. **AIREX RADIO CORP.**, 132 (RE) Nassau St., New York, N.Y. 10038

WHEN YOU ORDER MERCHANDISE BY MAIL . . .

- Be sure to include your name and address. Include your zip code number.
- Type or print if you can—if not, write clearly.
- Don't send cash! Remit by check or money order.
- Include allowances for postage charges if you know the weight of what you're ordering.
- Mention you saw it in

RADIO-ELECTRONICS

INVENTIONS & PATENTS

INVENTIONS-IDEAS developed. Cash/Royalty sales. Member: **UNITED STATES CHAMBER COMMERCE**, Raymond Lee, 130-U W. 42nd, New York City 10036

BUSINESS AIDS

JUST STARTING IN TV SERVICE? Write for **FREE 32 PAGE CATALOG** of Service Order books, invoices, job tickets, phone message books, statements and file systems. **OELRICH PUBLICATIONS**, 6556 W. Higgins, Chicago, Ill. 60656, New Hyde Park 5, N. Y.

1,000 Business Cards, "Raised Letters" \$3.95 postpaid. Samples. **ROUTH**, 5717 Friendswood, Greensboro, N. C. 27409

BUSINESS OPPORTUNITIES

EARN BIG MONEY EASILY in your spare time introducing prospective home buyers. Write **TROPICAL PARADISE HOMES**, P.O. Box 1372, Nassau, Bahamas

Business for sale—TELEVISION RADIO APPLIANCE SERVICE SHOP. Connected, well equipped in thriving small town with good payroll. Good location. Building under lease with 4140 sq. ft. floor. P.O. Box 5, Pittsboro, North Carolina 27312

ELECTRONICS

BARGAINS in Canadian Electronic equipment and surplus. Send \$1.00 for giant catalogs. **ETCO**, Box 741, Dept. R, Montreal, Canada

PROFESSIONAL ELECTRONICS PROJECTS—\$1 up. Catalog 25¢. **PARKS**, Box 25565A, Seattle, Wash. 98125

TUBES. "Oldies", latest. Lists free. **STEINMETZ**, 7519 Maplewood, Hammond, Indiana 46324

SURPLUS SEMICONDUCTORS and miniature electronic parts. Send 25¢ for catalog. **ECD COMPANY**, P.O. Box 1432, Plainfield, N. J. 07061

TV CAMERA KITS for experimenters and industry. Expanded line includes monitors, vidicons, lenses, tripods, slow scan, etc. **NEW 1967 catalog**, 10¢. **ATV RESEARCH**, Box 396-R, So. Sioux City, Nebr. 68776

"**JAPANESE ELECTRONICS INDUSTRY**" Monthly English Magazine. Sample \$1—Subscription \$10. **DEE**, 10639 Riverside, North Hollywood, Calif. 91602

RADIO & TV TUBES 33¢ each. One year guaranteed. Plus many unusual electronic bargains. Free catalog. **CORNELL**, 4217-E University, San Diego, California 92105

TRANSISTORS-DIODES—Components. Large selection. Write for **FREE** catalogue. **ELECTRONIC COMPONENTS CO.** Box 2902B, Baton Rouge, La. 70821

FREE CATALOG—Loads of electronic bargains. **R.W. ELECTRONICS, INC.**, 2244 So. Michigan Ave., Chicago, Illinois 60616

RECEIVING & INDUSTRIAL TUBES, TRANSISTORS, All Brands—Biggest Discounts. Technicians, Hobbyists, Experimenters—Request **FREE** Giant Catalog and **SAVE!** **ZALYTRON**, 469 Jericho Turnpike, Mineola, N.Y. 11501

FREE Catalog. Electronic parts, tubes. Wholesale. Thousands of items. Unbeatable prices. **ARCTURUS ELECTRONICS RE**, 502-22 St., Union City, N. J. 07087

TV CAMERAS, converters, etc. Lowest factory prices. Catalog 10¢. **VANGUARD**, 196-23 Jamaica Ave., Hollis, N.Y. 11423

JUST OFF THE PRESS!

FIELD SERVICE GUIDE FOR ALL RCA COLOR T.V. SETS MADE FROM 1955 TO 1967. POSTPAID \$2.25

NEW 1967 RCA TRANSISTOR CONVERSION MANUAL, 22—RCA S.K. TRANSISTORS WILL REPLACE 7200 TYPES ALL MAKES. POSTPAID 30¢

6146 XMITTING TUBES \$2.50. **WESTERN ELECTRIC 1000 WATT XMITTING TUBE.** NEW \$4.95

12-H & H SPST TOGGLE SWITCHES REMOVED FROM NEW EQUIPMENT

SPST 3 AMP.....\$1.00 PER DOZ.
SPST 6 AMP.....\$1.50 PER DOZ.
SPDT 3 AMP.....\$1.69 PER DOZ.
DPST 3 AMP.....\$1.69 PER DOZ.
DPDT 6 AMP.....\$2.39 PER DOZ.

DON'T BUY TUBES!!

RADIO or T.V.-XMITTING or SPECIAL-PURPOSE TYPES

UNTIL YOU GET OUR PRICE LIST GUARANTEED TO BE THE LOWEST PRICES IN THE U.S.A. OVER 5000 TYPES—ALL 100% GUARANTEED BRAND NEW

SEND POST CARD FOR T.V. OR SPECIAL PURPOSE PRICE LIST

NO COD'S—POSTAGE EXTRA

UNITED RADIO CO.

56 FERRY ST., NEWARK, N.J.
P.O. BOX 1000 - ZIP CODE - 07101

Circle 143 on reader's service card

UNUSUAL BARGAINS . . . MANY U. S. GOV'T SURPLUS

GIANT WEATHER BALLOONS



"Halls of fun" for kids, traffic stoppers for stores, terrific for amateur meteorologists. Create a neighborhood sensation. Great backyard fun. Exciting beach attraction. Made of heavy duty neoprene. Inflate with vacuum cleaner or auto air hose or locally available helium for high rise.
Stock No. 60,568EH
(8' diam.) \$2.00 Ppd.
Stock No. 60,632EH
(16' diam.) \$7.00 Ppd.

EXPERIMENTAL FUN WITH TESLA COIL

Now perform spectacular experiments without wires . . . as Nicola Tesla did 50 Yrs. ago. Generator with coil, etc., transmits extremely high frequency electromagnetic radiation (millions of cycles per second) through space. Lights fluorescent tube 2 ft. away, ionizes gases, performs total of 21 fascinating experiments. Incl. Neon Lamp, discharge electrode, 2 radiation antenna plates, generates 5,000 V. for 110 V. 60-C. AC. Mean. 8" x 6".
Stock No. 70,301EH \$44.00 Ppd.



ELECTROSTATIC GENERATOR

Volt potential—200,000, yet completely safe for classroom experiments. Demonstrate lightning and how lightning rods work! St. Elmo's fire; repulsion of like charges; electrostatic dust collectors; the classic "hair-raising effect"; many other electric phenomena. Motor, 110 V, 60-cycle AC. Humidity range, 0-80%. Current, 1.5 to 2.5 microamps. Aluminum base, frame and charge collector. Insulating column—unbreakable vinyl chloride plastic. Ht. 17". Dia. 6 1/2". Full instructions on experiments and care.
Stock No. 70,268EH \$43.50 Ppd.

Order by Stock No. Check or M.O.—Money-Back Guarantee. **EDMUND SCIENTIFIC CO.**, Barrington, N. J. 08007

CLIP AND MAIL COUPON TODAY

SEND FOR FREE CATALOG "EH"

Completely new 1987 edition. New items, categories, illustrations. Dozens of electrical and electromagnetic parts, accessories. Enormous selection of Astronomical Telescopes, Microscopes, Binoculars, Magnifiers, Magnets, Lenses, Prisms. Many war surplus items for hobbyists, experimenters, workshop, factory. Mail coupon for catalog "EH".



NAME _____
ADDRESS _____
CITY _____ STATE _____ ZIP _____

Circle 144 on reader's service card

SILICON RECTIFIER SALE

IMMEDIATE DELIVERY
FULLY GTD NEWEST TYPE
AMERICAN MADE FULLY TESTED



750 MA-SILICON "TOPHAT" & EPOXY DIODES
LOW LEAKAGE FULL LEAD LENGTH

PIV/RMS 50/35 .05 ea.	PIV/RMS 100/70 .07 ea.	PIV/RMS 200/140 .10 ea.	PIV/RMS 300/210 .12 ea.
PIV/RMS 400/280 .14 ea.	PIV/RMS 500/350 .19 ea.	PIV/RMS 600/420 .21 ea.	PIV/RMS 700/490 .25 ea.
PIV/RMS 800/560 .30 ea.	PIV/RMS 900/630 .40 ea.	PIV/RMS 1000/700 .50 ea.	PIV/RMS 1100/770 .70 ea.

ALL TESTS AC & DC & FWD & LOAD
SILICON POWER DIODE STUDS

D.C. AMPS	50 PIV 35 RMS	100 PIV 70 RMS	150 PIV 105 RMS	200 PIV 140 RMS
3	.08 ea.	.12 ea.	.16 ea.	.22 ea.
12	.25	.30	.40	.55
35	.75	.90	1.25	1.40
50	1.00	1.20	1.50	1.75
100	1.60	2.00	2.40	3.00

D.C. AMPS	300 PIV 210 RMS	400 PIV 280 RMS	500 PIV 350 RMS	600 PIV 450 RMS
3	.27 ea.	.29 ea.	.37 ea.	.45 ea.
12	.90	1.30	1.40	1.65
35	2.00	2.35	2.60	3.00
50	3.20	3.25	3.40	4.00
100	3.60	4.50	5.25	7.00

"SCR" SILICON CONTROLLED RECTIFIERS "SCR"

PRV AMP	16 AMP	25 AMP	PRV AMP	16 AMP	25 AMP
25	.50	.75	1.00	250	1.75
50	.60	.90	1.25	300	2.00
100	.80	1.25	1.50	400	2.40
150	.90	1.60	2.00	500	3.20
200	1.25	1.80	2.25	800	3.40

SPECIALS! SPECIALS!

Westinghouse 160 AMP, 500 PIV SILICON HI-POWER
STUD RECTIFIER IN1666. Limited quantity. \$5.10 ea. 10 for \$45.00

100 Different Precision Resistors
1/2-1-2 Watt 1/2%-1% TOL \$1.25

Asst transistor Kit. P.N.P.—N.P.N.
All popular types. Unchecked 100 for \$2.95 500 for \$9.95

Computer Grade Condenser 15,500 MFD
12 VDC American Mfg. .75 ea. Type IN34 DIODE GLASS .07 ea 100 for \$5

Money Back guarantee. \$2.00 min. order. Include additional \$ for postage. Send check or money order. C.O.D. orders 25% down.

Warren Electronic Components

230 Mercer St., N. Y., N. Y. 10012 • 212 OR 3-2620

Circle 145 on reader's service card

MARKET CENTER

Discharge IGNITION, PHOTOFLASH. Free catalog parts, kits. TRANSPARK, Carlisle, Mass. 01741

MESHNA'S TRANSISTORIZED CONVERTER KIT \$5.00 converts car radio to receive 30-50mH or 100-200mH (one MHz tuning). RON MESHNA, No. Reading, Mass. 01864

TELEPHONE RECORDER-ACTUATOR (TWI-007). Solid state module automatically turns tape recorder, amplifier, indicator light on when telephone in use. Connected anywhere on line. Simple installation instructions included. Prepaid \$22.85. Surveillance Recorders: (TWI-1000), (TWI-1010). TWILIGHT ELECTRONICS, Box 11595-R, St. Louis, Missouri 63105

"CRYSTAL SET CONSTRUCTION" Handbook—50¢. Catalog LABORATORIES, 12041-B Sheridan, Garden Grove, Calif. 92640

CANADIANS, TRANSISTORS AND PARTS. Free catalogue contains reference data on 300 transistors. J. & J. ELECTRONICS, Dept. RE, Box 1437, Winnipeg, Manitoba

AUTOMATIC DEGAUSSING easily added to Heath 21" Color TV. Information free. Box 2965-R Amarillo, Texas 79105

FREE CATALOG of 200 special slide rules and calculating aids. DYNA-SLIDE, 1566 Sherman Ave., Evanston, Illinois 60201

SIX GENERAL ELECTRIC MA 16W 6V 2-way radios. Also, Motorola Radio Paging system with 29 pocket receivers, dialing stations, transmitter cabinet. Contact the POWER AUTHORITY OF THE STATE OF NEW YORK, Post Office Box 700, Massena, New York 13662

8 PIECE TOOL KIT

69¢
10 Shipping
contains
4 Bristo
Wrenches
1 Hex Blade
2 Alignment
(tuning) Tools

INTERFERENCE TV TRAPPER

SUPPRESS PICTURE INTERFERENCE CAUSED BY:

- AUTO IGNITION
- AIRPLANES
- APPLIANCES
- NEON SIGNS
- OIL BURNERS
- AMATEUR RADIO TRANSMITTERS

159
10c Shipping

TV LIFESAVER!

STOP TUBE BURNOUTS!

PROTECTS TV TUBES FROM BURNOUT AND CUTS DOWN ON SERVICE CALLS! SAVED YOUR MONEY! ALSO USE WITH PHONOGRAPHS, TAPE RECORDERS, TV PRESETS WITH FEWER INTERRUPTIONS! ELECTRONIC TUBES AND BREAKDOWNS!

179
+ 20c shipping

CORNELL TUBES

1 YR. GUARANTEED

Mutual Conductance Lab-tested, Individually Boxed, Branded and Code Dated. Tubes are new, or used and so marked.

33¢ PER TUBE

100 TUBES OR MORE: 30¢ PER TUBE

OZ4	6A55	6CD6	6K6	6X4	12BF6
1B3	6AT6	6CF6	6K7	6X8	12BH7
1J3/1K3	6AT8	6CG7	607	7A7	12BL6
1H5	6AU4	6CG8	654	7A8	12BY7
1L4	6AU5	6CM7	6SA7	7B6	12C5
1T4	6AV6				12CA5
1U4	6AW8				12SN7
1X2	6AX4				12SQ7
3BZ6	6BA6				25L6
3DG4	6BC5				25Z6
5U4	6BD6	6CZ5	6SH7	7C5	35W4
5V4	6BG6	6D6	6SJ7	7N7	35Z3
5Y3	6BJ6	6DA4	6SK7	7Y4	50L6
6A6	6BL7	6DE6	6SL7	12AD6	24
6A8	6BN4	6DQ6	6SM7	12AE6	27
6AB4	6BN6	6E7	6SQ7	12AF6	77
6AC7	6BQ6	6EA7	6SR7	12AT7	78
6AG5	6BQ7	6F6	6U7	12AU7	84/6Z4
6AK5	6BZ6	6FM6	6U8	12AX7	5687
6AL5	6C4	6H6	6V6	12BA6	6350
6AN8	6C6	6J5	6W4	12BD6	6463
6AQ5	6CB6	6J6	6W6	12BE6	7044

Other tubes at low prices—send for free list

NO SUBSTITUTIONS WITHOUT YOUR PERMISSION

Special!

With every \$10 Order

25¢ per tube

(No Limit) from this list

6AG5	6SN7
6AQ5	6CB6
6AU6	6J6
6W4	

NEW! EASY TO USE!

COLOR TV, 395

DEGAUSSER \$40 shipping

BARGAIN CORNER

Solder Iron	1.49
Elect Tape	.89
Epoxy (pr.)	.79
Diode Kit	.39
Noise Filter	.89
Neon Tester	.59
Solder	.39
Antenna Coupler	1.89
Battery Charger	4.95

Prestige & Success are yours as an ELECTRONIC EXPERT

FOR CORNELL CUSTOMERS ONLY by special arrangement with the publisher, these amazing bargains are available.

COMPLETE RADIO SERVICING AND BASIC ELECTRONICS COURSE ONLY \$3.00 (12 1/2" x 9" package)

NEW PRACTICAL TV TRAINING COURSE ONLY \$3.50 (12 1/2" x 9" package)

Both above courses \$6.00

SILICON RECTIFIERS

all purpose ELECTRONIC CLEANER

89¢ plus 20c shipping

TUBE CARTONS

HIGH GLOSS CLAY COATED

SIZE	PRICE PER 10 CARTONS	PRICE PER 100 CARTONS
1/2" x 1/2"	29	2.59
1" x 1"	39	3.49
1 1/2" x 1 1/2"	59	5.29
2" x 2"	89	7.99

TUBE SUBSTITUTES

1.25

RADIO-TV TUBE TESTER

289 plus 30c shipping

TEST AND REPAIR TV & RADIO SETS APPLIANCES

SEND FOR FREE CATALOG

CORNELL ELECTRONICS CO.

Dept. RE 6 4217 University Ave. San Diego, Calif. 92105

TERMS: Add 3c per tube shipping. Orders under \$5.00 add 3c per tube shipping plus 50c handling. Canadian orders add approximate postage. Send 25% deposit on C.O.D. orders. No C.O.O. orders under \$5.00 or to Canada. No 24 hr. free offer on personal check orders. 5-DAY MONEY BACK OFFER

Circle 146 on reader's service card

GOVERNMENT SURPLUS

72 page illustrated Government Surplus Radio, Gadgets Catalog 25¢. MESHNA, Nahant, Mass. 01908

EDUCATION/ INSTRUCTION

LEARN ELECTRONIC ORGAN SERVICING. New home study course covering all makes electronic organ including transistors. Experimental kits—schematics—trouble-shooting. Accredited NHC-GI Approved. Write for free booklet. NILES BRYANT SCHOOL, 3631 Stockton Blvd., Dept. F, Sacramento 20, Calif.

FCC LICENSE in 6 weeks. First Class Radio Telephone. Results Guaranteed. ELKINS RADIO SCHOOL, 2603E Inwood, Dallas, Tex.

LEARN TECHNICAL WRITING—at home. High paying prestige careers not requiring college. Growing demand, all industries for tech writers now. Low monthly tuition. Easy to understand. FREE career book, sample lesson. APPROVED FOR VETERANS. AMERICAN TECHNICAL WRITING SCHOOLS, Dept. REC-67, 5512 Hollywood Blvd., Hollywood, Calif. 90028

"TAB" • SILICON ONE-AMP DIODES
Full Leads Factory Tested & Gd! U.S.A. Mfg

Piv/Rms	Piv/Rms	Piv/Rms	Piv/Rms
50/35	100/70	200/140	300/210
.05	.07	.10	.12
400/280	600/420	800/560	900/630
.14	.21	.30	.40
1000/700	1100/770	1700/1000	2400/1680
.50	.70	1.20	2.00

"TAB" TERMS: Money Back Guarantee
Our 22nd Year. \$2 Min. Add Shipping Charges
111 GD LIBERTY ST., N. Y. 6, N. Y.
Send 25¢ Phone: REctor 2-6245 for Catalog

CORRESPONDENCE COURSES—B.Sc., Engineering, Electronics, Catalog \$1. CANADIAN INSTITUTE OF SCIENCE & TECHNOLOGY, 263E Adelaide St. W., Toronto

WANTED! TV-RADIOMEN to learn aircraft electronics servicing. Numerous job openings everywhere. Write: ACADEMY AVIONICS, Reno/Stead Airport, Reno, Nevada

SLEEP LEARNING. Hypnotism! Tapes, records, books, equipment. Details, strange catalog FREE. RESEARCH ASSOCIATION, Box 24-RD, Olympia, Wash.

HIGHLY EFFECTIVE HOME STUDY COURSE in Electronics Engineering Mathematics with circuit applications. Earn your Associate in Science degree. Free literature. COOK'S INSTITUTE OF ELECTRONICS ENGINEERING, P.O. Box 36185, Houston, Texas 77036 (Established 1945.)

HIGHLY EFFECTIVE HOME STUDY REVIEW for FCC commercial phone exams. Free literature. COOK'S SCHOOL OF ELECTRONICS, P.O. Box 36185, Houston, Texas 77036

ASSOCIATE DEGREE IN ELECTRONICS earned, first half by correspondence and second half in residence. Free catalog. GRANTHAM INSTITUTE, 1505 N. Western Ave., Hollywood, Calif. 90027

SERVICES

Transistorized products dealers catalog. \$1. INTERMARKET, CPO 1717, Tokyo, Japan.

KITS, TEST EQUIPMENT REPAIRED to factory specifications. MAILTRONICS, 109 Pinetree, Woodbridge, Va. 22191

CLASSIFIED COMMERCIAL RATE (for firms or individuals offering commercial products or services): 60¢ per word . . . minimum 10 words.

NON-COMMERCIAL RATE (for individuals who want to buy or sell personal items): 30¢ per word . . . no minimum.

Payment must accompany all ads except those placed by accredited advertising agencies. 10% discount on 12 consecutive insertions, if paid in advance. Misleading or objectionable ads not accepted. Copy for July issue must reach us before May 10th.

WORD COUNT: Include name and address. Name of city (Des Moines) or state (New York) counts as one word each. Zone or Zip Code numbers not counted. (We reserve the right to omit Zip Code if space does not permit.) Count each abbreviation, initial, single figure or group of figures or letters as a word. Symbols or groups such as 8-10, COD, AC, etc., count as one word. Hyphenated words count as two words. Minor over-wordage will be edited to match advance payment.

CLASSIFIED ADVERTISING ORDER FORM

For complete data concerning classified advertising please refer to box elsewhere in Market Center section.

1	2	3	4	5
6	7	8	9	10
11	12	13	14	15
16	17	18	19	20
21	22	23	24	25
26	27	28	29	30
31	32	33	34	35

No. of Words { @ .30 Non-Commercial Rate } = \$
 { @ .60 Commercial Rate }

Total Enclosed \$

Insert _____ time(s)

Starting with _____ issue

Payment must accompany order unless placed through accredited advertising agency 67

NAME _____

ADDRESS _____

CITY _____ STATE _____ ZIP _____

SIGNATURE _____

MAIL TO: RADIO-ELECTRONICS, CLASSIFIED AD DEPT., 154 WEST 14TH ST., NEW YORK, N.Y. 10011

MONEY BACK GUARANTEE

Solid State KING SALE

FREE WORTH OF
• Transistors
• Diodes
• Rectifiers
• Knobs
• Condensers
• Coils, etc.

\$25

Include 25¢ for handling

DOUBLE BONUS

FREE POLY PAK OF YOUR CHOICE

BOTH FREE WITH EVERY \$10 ORDER

New! 'PANCAKE' Transistors
IN THE NEW TO46 MICRO CASES

■ Silicon Epitaxial Planars ■ 70% off
■ Only 1/16" high ■ Gold nivar leads Tested

Like	Watts	VCB*	HFE	FREQmc	NPN
2N706	.4	20	20	200	
2N870	.5	60	120*	80	
2N1613	.8	50	120*	80	
2N1893	.8	100	120*	70	
2N2049	.8	50	300*	85	
2N2434	.5	80	185	100	
2N2645	.5	50	300*	85	

5 For \$1

3. SILICON CONTROLLED RECTIFIERS

PRV	AMP	PRV	AMP
50	30	400	1.60
100	50	500	2.10
200	80	600	2.50

1 AMP 1000 PIV SUBMINIATURE RECTIFIERS for \$1

Delco LIKE DS501.

75¢ EA.

INTEGRATED CIRCUITS

6 for \$1.89

Flip Flops
Nand Nor Gates
Dual-Inline: TO-5, that package

ZENER RECTIFIERS

Tested	Volts	Volts	Volts	Volts
□	5.4	18	43	82
□	6.4	20	47	91
□	8.0	22	51	120
□	9.1	24	58	130
□	10	27	62	150
□	12	30	68	160
□	13	33	75	180

1 AMP TOP HAT AND EPOXIES

PIV	Sale	PIV	Sale	PIV	Sale
50	5¢	600	19¢	1400	69¢
100	7¢	800	25¢	1600	89¢
200	9¢	1000	45¢	1800	99¢
400	11¢	1200	59¢	2000	1.50*

SILICON POWER STUD RECTIFIERS

AMPS	Factory	50 PIV	100 PIV	200 PIV
3	7¢	11¢	17¢	17¢
15	22¢	40¢	65¢	65¢
45	75¢	90¢	1.25	1.25
AMPS	400 PIV	600 PIV	800 PIV	1000 PIV
3	22¢	31¢	40¢	59¢
15	90¢	1.35	1.59	1.79
45	1.59	1.90	2.50	2.95

'GLASS AMP' ONE AMP SILICON RECTIFIERS

288

DC 0-100 Microamp

PIV	Sale	PIV	Sale
50	7¢	600	19¢
100	9¢	800	29¢
200	11¢	1000	45¢
400	13¢	1200	59¢

10¢ FOR OUR 'SUMMER' BARGAIN CATALOG ON:

□ Semiconductors □ Poly Paks □ Parts

POLY PAKS

TERMS: send check, money order, include postage—avg. wt. per pak 1 lb. Rate! net 30 days. CODs 25%.

P.O. BOX 942R
SO. LYNNFIELD, MASS.
"PAK-KING" of the World

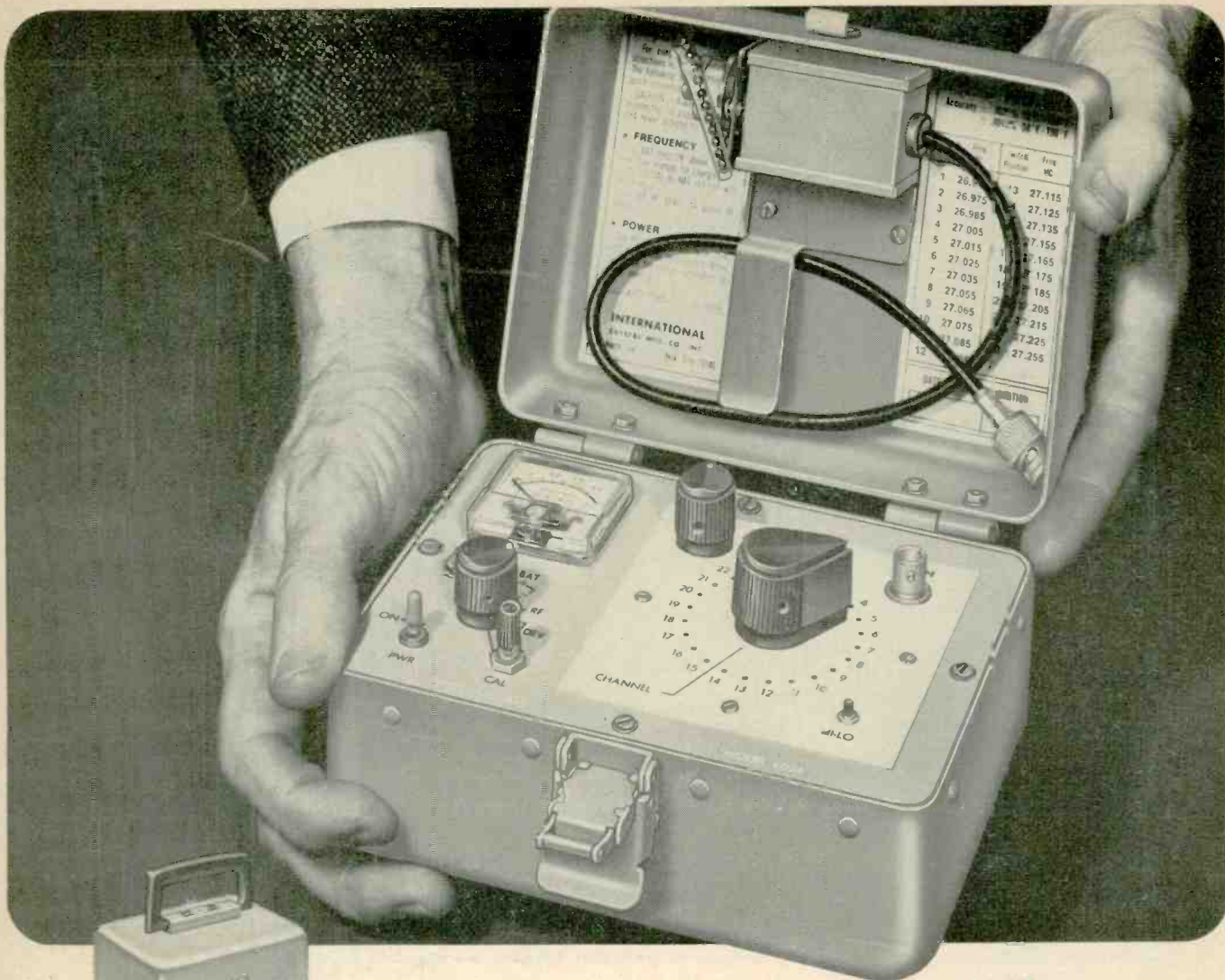

... THREE IN ONE

INTERNATIONAL'S 6024 FREQUENCY METER

- SECONDARY FREQUENCY STANDARD
- SIGNAL GENERATOR
- POWER METER

The all new 6024 packs three test instruments into one small package for fast, professional servicing on all makes of Citizens Radio transceivers. You have at the flick of a switch, a SECONDARY FREQUENCY STANDARD, range 26.965 to 27.255 MHz with Counter Circuit, zero to 2500 Hz; SIGNAL GENERATOR, 26.965 to 27.555 MHz and DUMMY LOAD/POWER METER, up to 5 watts.

Order your International 6024 today! It's all new.

Complete with connecting cable, dummy load, rechargeable battery and charger. **\$345.00**

Circle 148 on reader's service card



THE 6024 COMES COMPLETE WITH CHARGER.

WRITE FOR CATALOG



CRYSTAL MFG. CO., INC.
10 NO. LEE • OKLA. CITY, OKLA. 73102

RADIO-ELECTRONICS

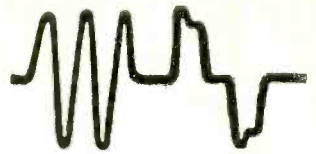

When you need a stable capacitor...

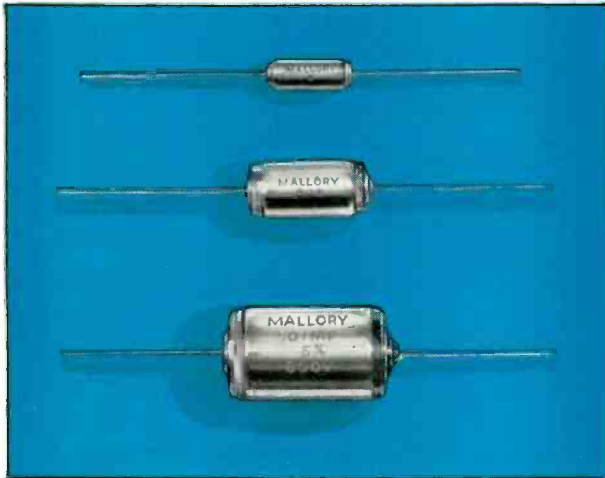

Temperature makes most capacitors wander. For electrolytics, capacitance goes down when temperature gets colder, goes up when things get hot. But this usually doesn't cause trouble, because most electrolytic applications are in filtering—and as long as you have low enough AC impedance, you get the filtering you need. Where drift can bring problems is in tuned circuits, timing and differentiator circuits; here you've got a paper, film, ceramic or mica capacitor, in the fractional-microfarad range. If it changes value due to temperature variations or just plain old age, you're going to have some headaches.

Today's tip: when you need extra stability, try the *new* Mallory polystyrene capacitors. They're the most stable you've ever seen. They look different, and they act different. They're made of a unique kind of stretched polystyrene film and high purity aluminum foil, wound up in a compact roll and then fused together in a self-sealed case of solid clear plastic.

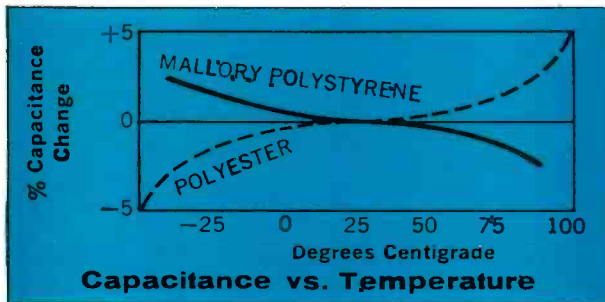

What's extra special about these new capacitors is the way they hold their original microfarad value while temperature varies all over the lot. Temperature coefficient is considerably lower than that of polyester film capacitors—under 150 parts per million per degree C. And it's negative—which means that instead of going up with temperature, capacitance goes down. This is the direction you need to change capacitance in order to compensate for the effect of temperature on the inductive part of a tuned circuit. From -10°C to $+70^{\circ}\text{C}$, their *total* capacitance change is less than 1.3%. And brother, that's *stable!*

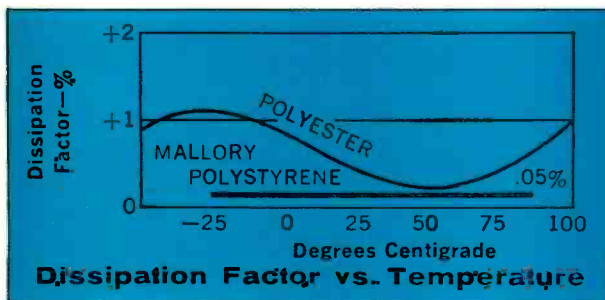

And that's not all. These little dandies don't grow old. They hold their characteristics month after month. You just connect 'em and forget 'em.

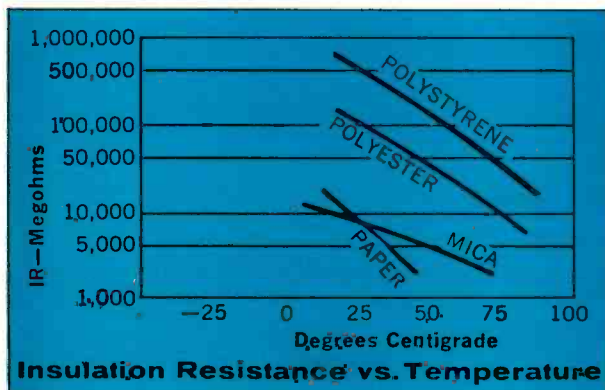

One more thing. Mallory Polystyrene Capacitors have the lowest dielectric loss in the business. Their dissipation factor (similar to power factor, a measure of efficiency as a capacitor) is extremely low . . . only 0.05%, which is a small fraction of that of other capacitors. And it stays at this low value over the whole temperature range. This means that they're high Q capacitors, ideal for tuned circuits. And their insulation resistance is way higher than polyester, mica or paper capacitors.

In case you were wondering how much dough you would have to lay out to get such wonderful capacitors—here's the best news of all. They are really low priced. You can get them in values from 5 pF to .01 mfd, all rated 600 volts, from your Mallory Distributor. See him soon—and ask for your copy of the 1967 Mallory General Catalog. Mallory Distributor Products Company, a division of P. R. Mallory & Co. Inc., Indianapolis, Indiana 46206.

Circle 149 on reader's service card



How else but with RCA HI-LITE color picture tubes can you bring today's color to your customers?

Your service reputation is the cornerstone of your business. That's why there's no room to compromise with quality in the components you install.

RCA HI-LITE picture tubes enable you to offer your customers TODAY'S COLOR... incorporating the latest technology of the world's most experienced picture tube manufacturer. They're the same tubes that go into today's major and minor equipment sets.

RCA's new Perma-Chrome process for rectangular picture tubes, for example, means locked-in color purity from the moment the picture comes on. Faster servicing for you. Added customer satisfaction.

Install an RCA HI-LITE and you literally "up-date" your customer's set while, at the same time, enhancing your service reputation.

RCA Electronic Components and Devices, Harrison, N.J.



The Most Trusted Name in Electronics